

Chief Universal Measuring System

Includes Related
Accessories

PARTS MANUAL





CHIEF'S LIMITED ONE-YEAR WARRANTY & LIABILITY

Chief Automotive Technologies, Inc. warrants for one year from date of installation and/or purchase any of its products which do not perform satisfactorily due to defect caused by faulty material or workmanship. Chief's obligation under this warranty is limited to the repair or replacement of products which are defective and which have not been misused, carelessly handled, or defaced by repair or repairs made or attempted by others.

CHIEF AUTOMOTIVE TECHNOLOGIES, INC. DOES NOT ASSUME RESPONSIBILITY FOR ANY DEATH, INJURY OR PROPERTY DAMAGE RESULTING FROM THE OPERATOR'S NEGLIGENCE OR MISUSE OF THIS PRODUCT OR ITS ATTACHMENTS. CHIEF MAKES NO WRITTEN, EXPRESS OR IMPLIED WARRANTY WHATSOEVER OF MERCHANTABILITY OR FITNESS FOR A PARTICULAR PURPOSE OR OTHERWISE REGARDING THE EQUIPMENT OR ANY PART OF THE PRODUCT OTHER THAN THE LIMITED ONE-YEAR WARRANTY STATED ABOVE.

INTRODUCTION

If it becomes necessary to order replacement parts for the Universal Measuring System or any of its optional accessories, contact a Chief Automotive Technologies, Inc. representative, 308-384-9747 (800-445-9262 in USA only). If calling after hours, leave a message on the answering machine and your local representative will be

contacted at the start of the next business day. When contacting Chief Automotive Technologies, Inc. by telephone or mail, provide the following information: name, name of business, business telephone number and business address. Additional information needed when ordering: description of parts and part numbers.

UNIVERSAL MEASURING SYSTEM

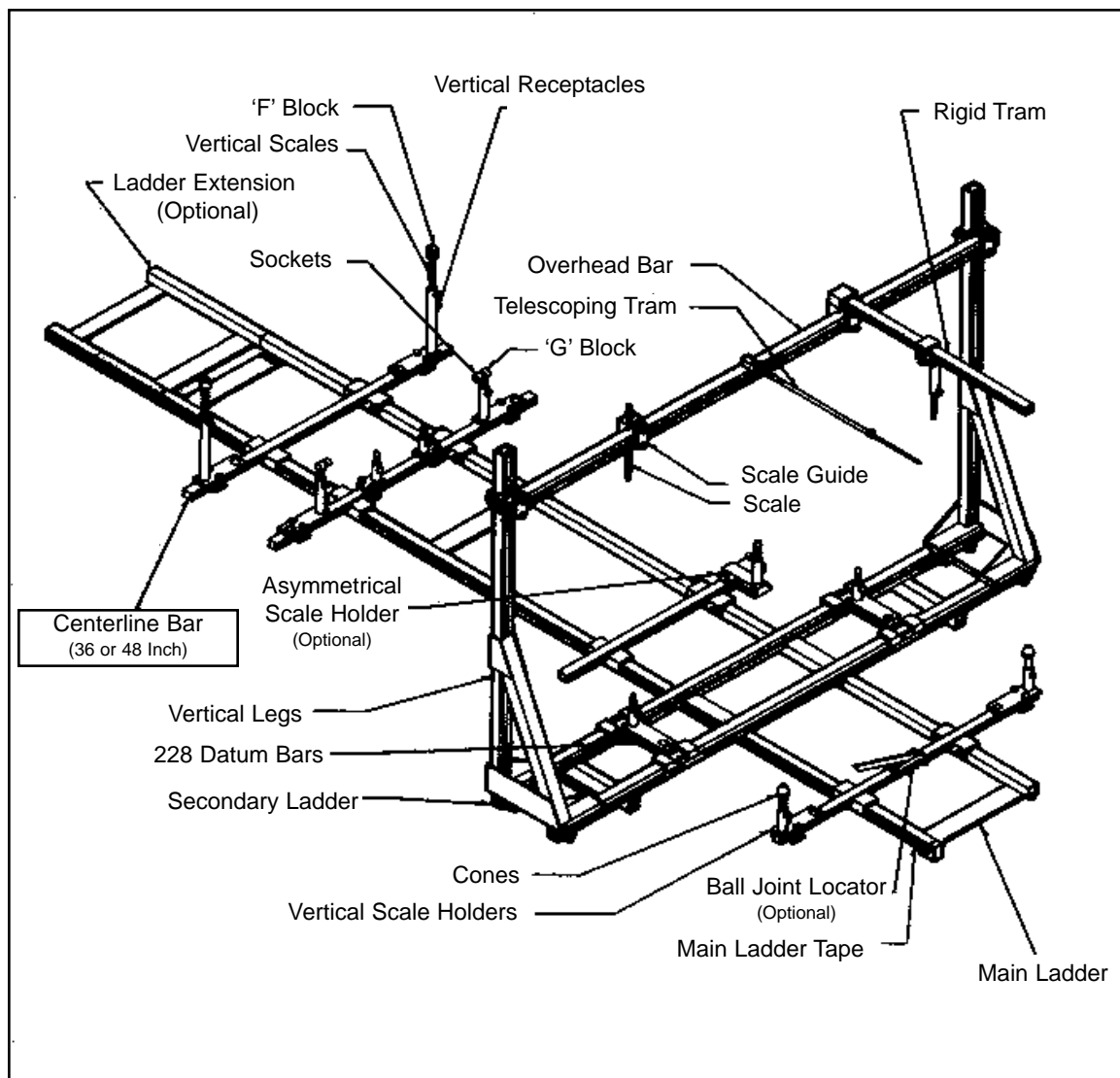

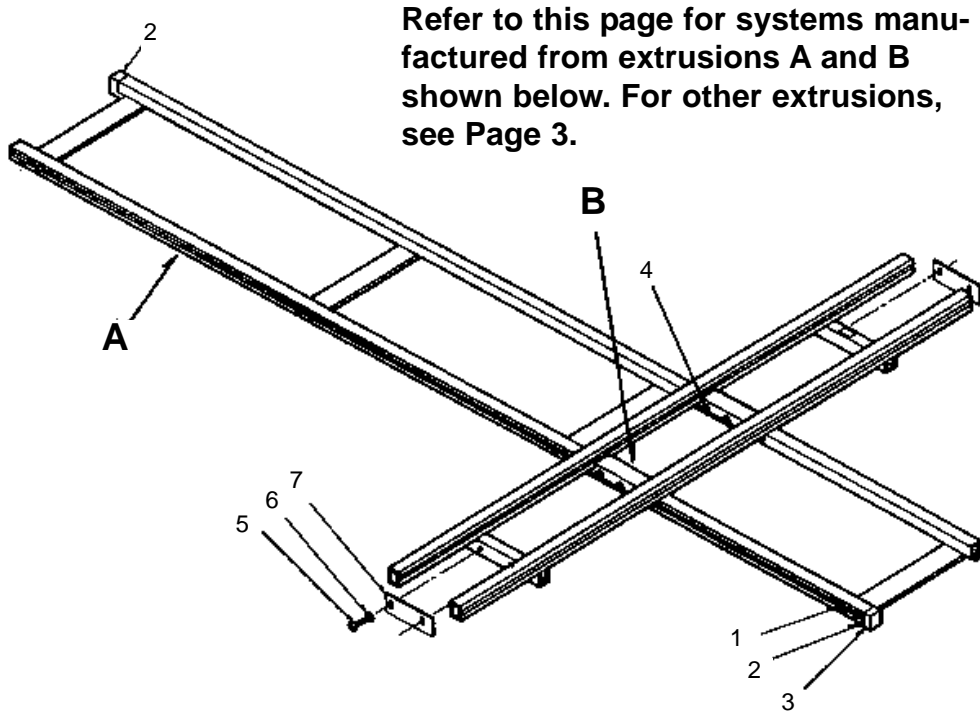

Refer to this page for systems manufactured from extrusions A and B shown below. For other extrusions, see Page 3.

**Main Ladder Assembly
(Part No. 309115)**

**Secondary Ladder Assembly
(Part No. 309219)**

Ref	Part No	Description
	309115	Main Ladder Assembly, Complete (N/S)
1	092128	UMS Main Ladder Tape
2	092127	Tape Guide, Nylon, 2" x 1 1/2"
3	011058	SHCS Black, 1/4" x 1 1/2"
	309219	Secondary Ladder Assembly (N/S)
4	309413	SHCS Assembly, 1/4 x 3/4 (N); 1" Knob
5	309423	SHCS Assembly, 1/4 x 1; 1" Knob
6	707410	Washer, 1/4", Flat, SAE
7	301218	Plate, Adjustable, BA, 3/8 x 2 1/2 x 8"



End view of extrusions used to manufacture systems with serial numbers 0579, 0607 and up.

Centerline Bar Assemblies

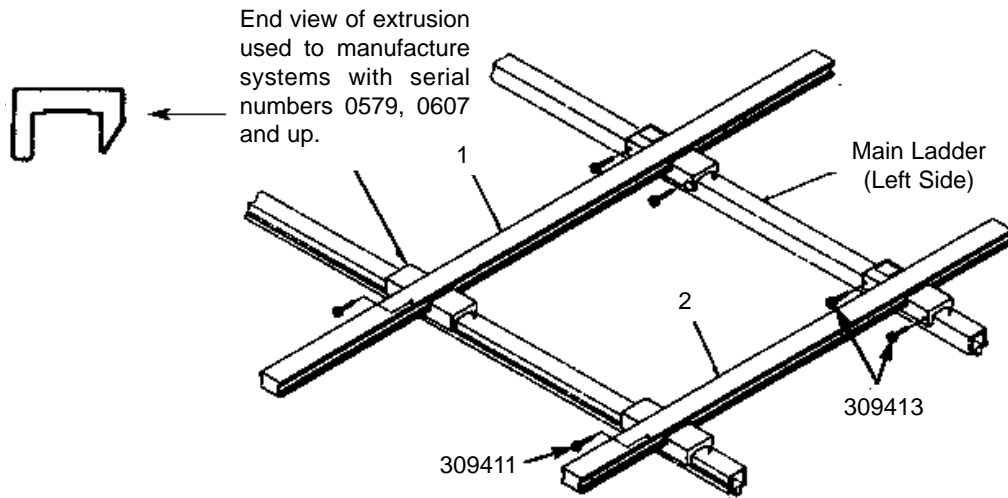

Included in 309622 and 309623 are: 2 per centerline bar, 309413 Socket Head Capscrew Assembly 1/4" x 3/4" (N); 1" Knob. 1 per centerline bar, 309411 Socket Head Capscrew Assembly 1/4" x 3/4" (N); 3/4" Knob.

Ref.	Part No	Description
1	309662	Centerline Bar Assembly, 48" N/S
2	309623	Centerline Bar Assembly, 36" N/S

Vertical Leg Assembly (Right)
Part No. 309300

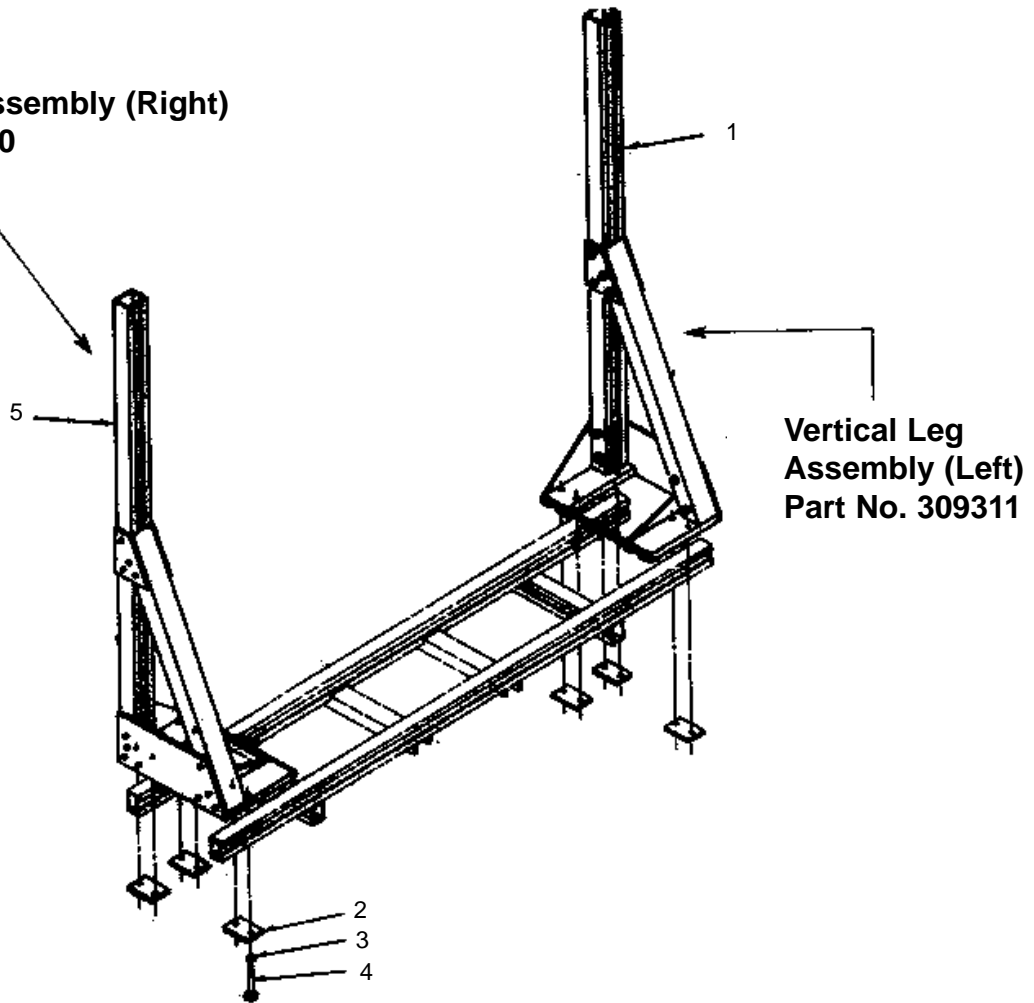

Vertical Leg
Assembly (Left)
Part No. 309311

Ref.	Part No.	Description
	309311	Vertical Leg Assembly, LH CMP
1	309317	Vertical Leg, LH Only
2	301308	Plate, BA, 3/8 x 2 1/2 x 2" ALMFLT
3	707410	Washer, 1/4", Flat, SAE
4	309419	SHCS Assembly, 1/4 x 2 3/4; 1" Knob
	309300	Vertical Leg Assembly, RH, CMP
5	309318	Vertical Leg, RH Only
2	301308	Plate, BA, 3/8 x 2 1/2 x 2" ALMFLT
3	707410	Washer, 1/4", Flat, SAE
4	309419	SHCS Assembly, 1/4 x 2 3/4; 1" Knob

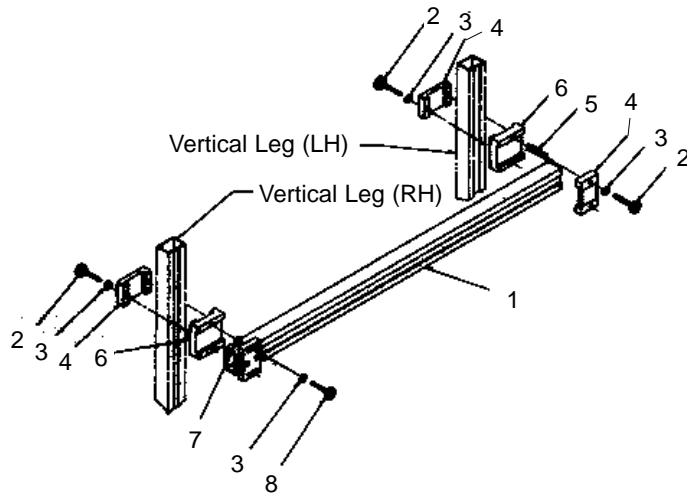

**Overhead Bar/Mounting Assembly
Part No., 309515**

Ref	Part No	Description
	309515	Overhead Bar And Mounting Assembly
1	309516	Overhead Bar Sub-Assembly
2	309417	SHCS Assembly, 1/4 x 2 1/4; 1" Knob
3	707410	Washer, 1/4", Flat, SAE
4	301501	Clamp, 2", BA
5	092109	Spring, Complete, 7/16" x 1 1/2"
6	301504	Clamp, 1 x 3 x 2.950", ALMFLT BA
7	301626	Sleeve, 3/8" with 1/4-20 Threaded
8	309416	SHCS Assembly, 1/4 x 2: 1" Knob

**Rigid Tram Assembly
Part No. 309030**

Ref	Part No	Description
	309030	Rigid Tram Assembly, Complete
1	309700	Rigid Tram Sub-Assembly
2	309628	Vertical Scal Holder, 1HLE Assembly (See Page 9 for Piece Parts)
3	309508	Scale Guide Assembly
4	301519	Guide, 1 3/4 x 3 x 2.5", ALMFLT, BA
5	301518	Clamp, 2", BA, D#4657
6	707410	Washer, 1/4", Flat, SAE
7	309415	SHCS Assembly, 1/4 x 1 3/4: 1" Knob
8	011059	SHCS Black, 1/4-20 x 1 3/4 BOP
9	309413	SHCS Assembly, 1/4 x 3/4 (N); 1" Knob

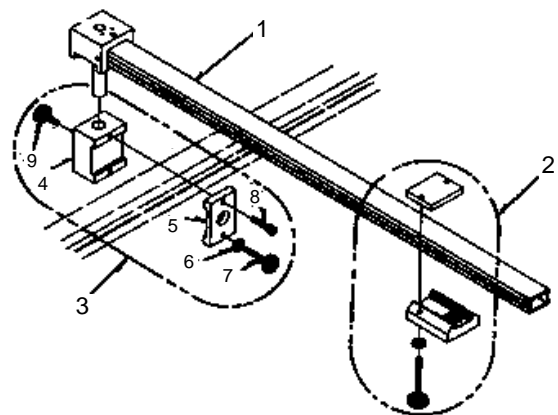

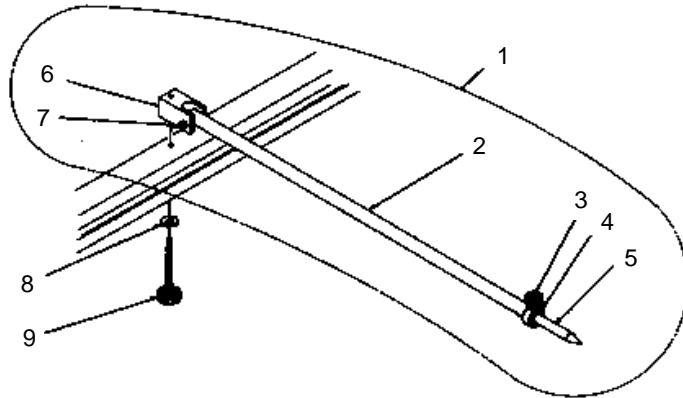

Telescoping Tram Assembly
Part No. 309509

Ref	Part No	Description
	309509	Telescoping Tram, Complete
1	309510	Telescoping Tram Assembly
2	301511	Tube, CA, 5/8" OD x .065W x 22", ALTB
3	309410	SHCS Assembly, 1 4 x 1/2 (N); 3/4" Knob
4	301514	Collar, BA, 1" OD x .185W .375", ALTB
5	301512	Pointer, CA, 7/16" Diameter x 22", ALRD
6	301513	Bracket, BA, 1" Square x 2.5" ALM Square
7	011056	SHCS, Black, 1/4 x 1
8	707410	Washer, 1/4", Flat, SAE
9	309418	SHCS Assembly, 1/4 x 2 1/2: 1" Knob

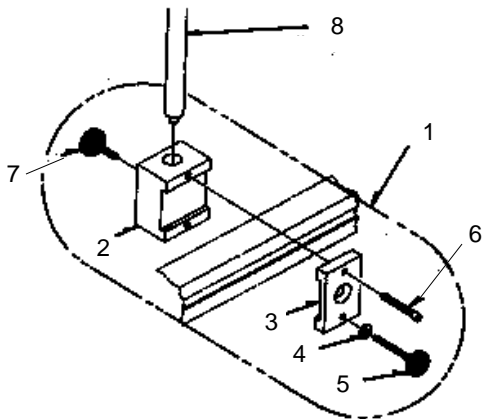

Vertical Scale Guide Assembly
Part No. 309505

Ref	Part No	Description
	309505	Scale and Scale Guide Assembly
1	309508	Scale Guide Assembly
2	301519	Guide, 1 3/4 x 3 x 2.5", ALMFLT, BA
3	301518	Clamp, 2", BA, D#4657
4	707410	Washer, 1/4", Flat, SAE
5	309415	SHCS Assembly, 1/4 x 1 3/4: 1" Knob
6	011059	SHCS Black, 1/4-20 x 1.75 BOP
7	309413	SHCS Assembly, 1/4 x 3/4 (N); 1" Knob
8	309811	Scale Assembly, 0/214mm 11.500"

Vertical Scale Holder Assemblies
Part Nos. 309627, 309628

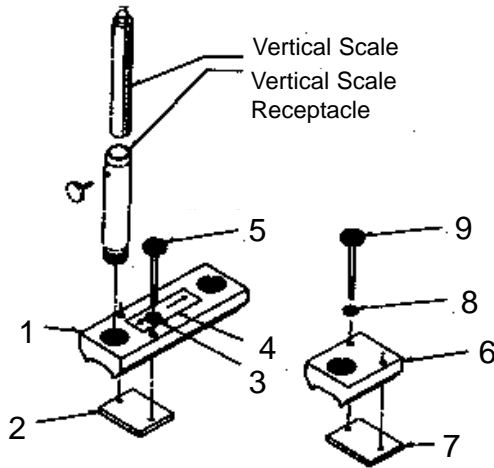

Ref	Part No	Description
	309627	Vertical Scale Holder, 2HLE Assembly
1	301612	Vertical Scale Holder, 2HLE, BA, D#4301
2	301609	Plate, BA, 3/8 x 2 1/2 x 2", ALMFLT
3	707410	Washer, 1/4", Flat, SAE
4	090709	Decal, 150mm
5	309417	SHCS Assembly, 1/4 x 2 1/4; 1" Knob
	309628	Vertical Scale Holder, 1HLE Assembly
6	301613	Vertical Scale Holder, 1HLE, BA, D#4301
7	301609	Plate, BA, 3/8 x 2 1/2 x 2", ALMFLT
8	707410	Washer, 1/4", Flat, SAE
9	309417	SHCS Assembly, 1/4 x 2 1/4; 1" Knob

228mm Datum Bar Assembly
Part No. 309601

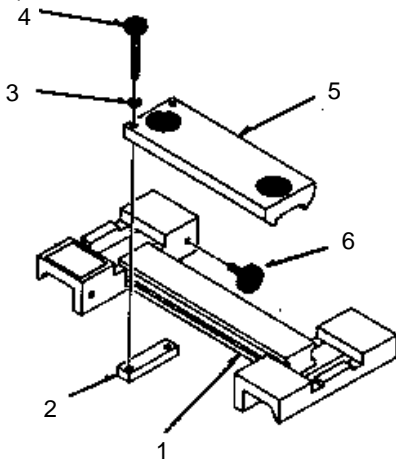

Ref	Part No	Description
	309601	228mm Datum Bar Assembly
1	309609	228mm Datum Bar Sub-Assembly
2	304606	Plate, BA ALFLT, 3/8 x 3/4 x 2.5"
3	707410	Washer, 1/4", Flat, SAE
4	309412	SHCS Assembly, 1/4 x 2; 3/4" Knob
5	304605	Scale Holder, 7.5", BA, D#4301
6	309413	SHCS Assembly, 1/4 x 3/4 (N) 1" Knob

Cones, Fittings, 'X' and 'K' Body Adapters

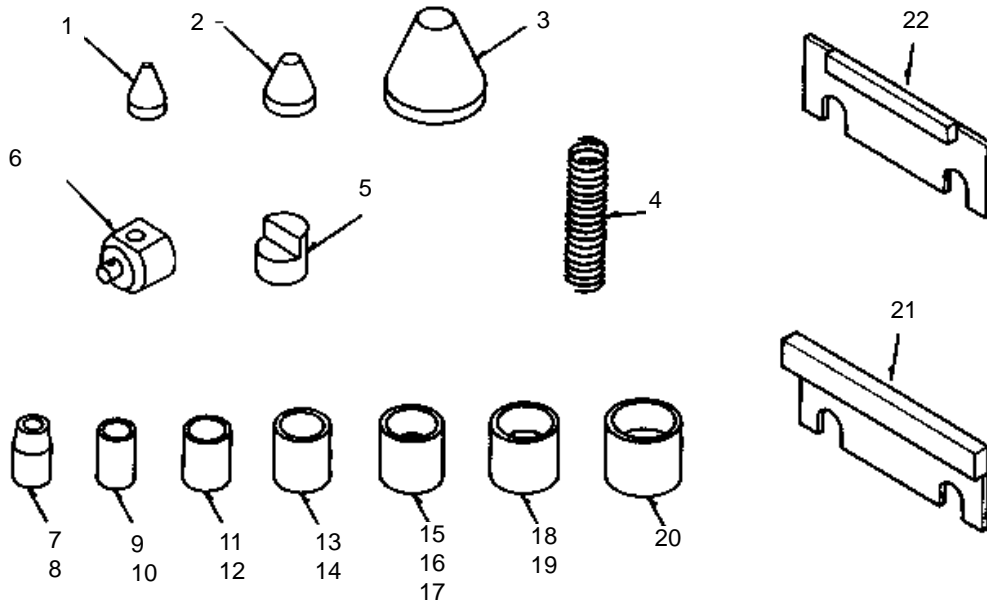

Ref	Part No	Description
1	091820	C-Cone
2	091821	B-Cone
3	091822	A-Cone
4	092108	Spring, Compression, 3/4 x 3 1/4"
5	091835	"F" Block
6	309834	"G" Block Assembly
7	091823	#9 Socket (Black)
8	091824	#10 Socket
9	091825	#11 Socket (Black)
10	091826	#12 Socket
11	091827	#13 Socket (Black)
12	091828	#14 Socket
13	091829	#15 Socket (Black)
14	091830	#16 Socket
15	091831	#17 Socket (Black)
16	091832	#18 Socket
17	091833	#19 Socket (Black)
18	091862	#21 Socket (Black)
19	091863	#22 Socket
20	091865	#24 Socket
21	309500	X-Body Clamp Adapter
22	508525	K-Body Clamp Adapter

**Vertical Scale Receptacles
Vertical Scales**

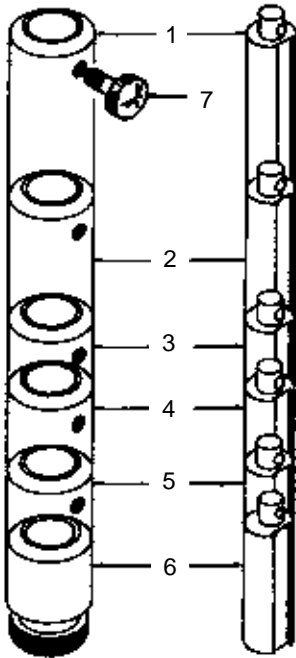

**Optional
Vertical Scale Receptacle
Vertical Scale (550-1,000mm)**

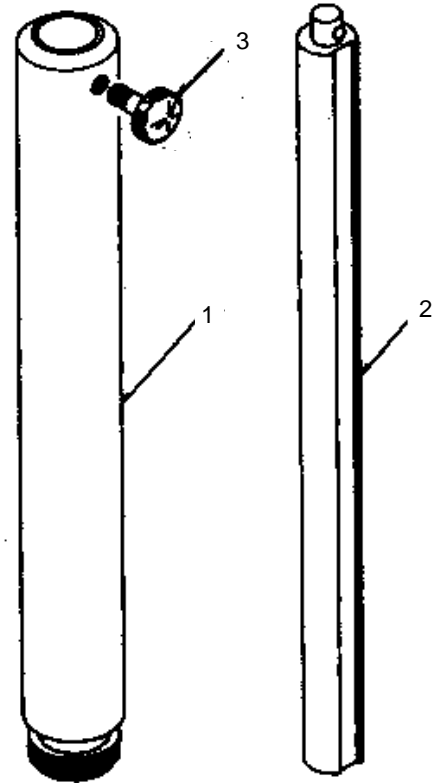

Ref	Part No	Description
1	309851	Receptacle/Scale Assembly
	309801	Receptacle Assembly
	309806	Scale Assembly (Tape 284/530mm)
2	309852	Receptacle/Scale Assembly
	309802	Receptacle Assembly
	309807	Scale Assembly (Tape 208/370mm)
3	309853	Receptacle Scale Assembly
	309803	Receptacle Assembly
	309808	Scale Assembly (Tape 151/260mm)
4	309854	Receptacle/Scale Assembly
	309804	Receptacle Assembly
	309809	Scale Assembly (Tape 110/185mm)
5	309855	Receptacle/Scale Assembly
	309805	Receptacle Assembly
	309810	Scale Assembly (Tape 81/145mm)
6	309857	Receptacle/Scale Assembly
	309812	Receptacle Assembly
	309813	Scale Assembly (Tape 56/90mm)
7	309410	SHCS Assembly, 1/4 x 1/2" (Nylon), 3/4" Knob

Ref	Part No	Description
	319867	Receptacle/Scale Assembly (1 only)
1	319868	Receptacle Assembly
2	319870	Scale Assembly (Tape 550/1000mm)
3	309410	SHCS Assembly, 1/4 x 1/2" (Nylon) 3/4" Knob

**Optional
Ball Joint Locator
Part No. 319614**

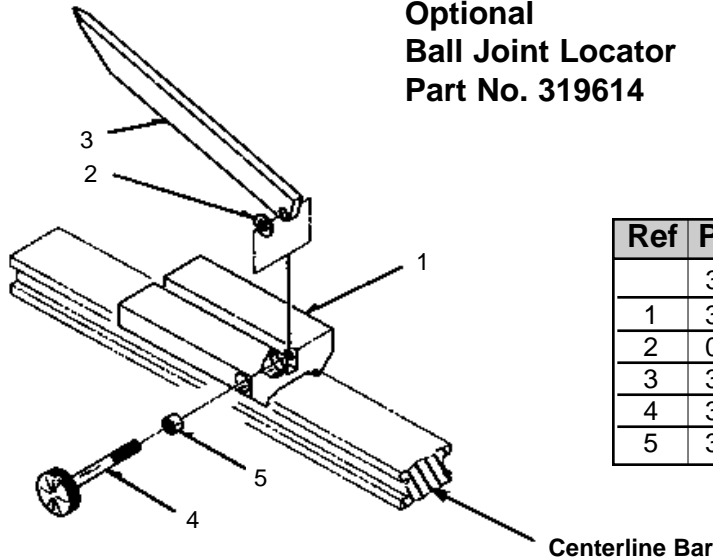

Ref	Part No	Description
	319614	Ball Joint Locator Assembly
1	311616	Pointer Guide, BA, 4", D#4301
2	092140	Washer, Steel, AN, #960-416L
3	311615	Pointer, CA, 1/4 x 3/4 x 7", ALMFLT
4	309418	SHCS assembly, 1/4 x 2 1/2; 1" Knob
5	301626	Nut, 1/4", Rounded and Machined

**Optional
Asymmetrical Vertical Scale Holder
Part No. 319621**

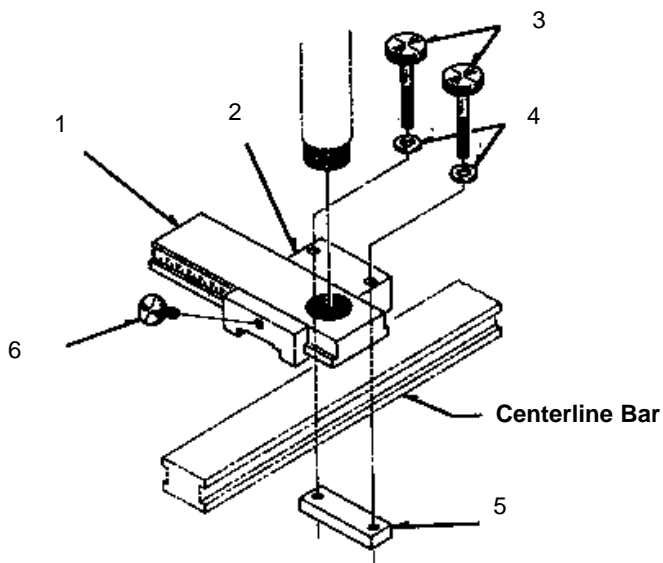

Ref	Part No	Description
	319621	Asymmetrical Vertical Scale Holder
1	311650	Scale Holder/Tape Assembly
2	311618	Guide, BA, 3.5", D#4658
3	309417	SHCS Assembly, 1/4 x 2 1/4; 1" Knob
4	707410	Washer, 1/4", Flat, SAE
5	304606	Plate, BA, ALFLT, 3/8 x 3/4 x 2.5"
6	309411	SHCS Assembly, 1/4 x 3/4 (N); 3/4" Knob

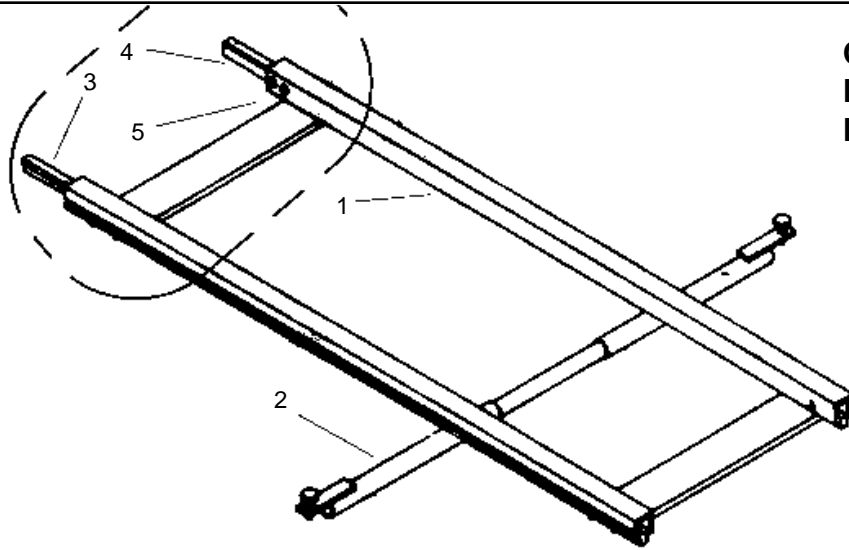

**Optional
Ladder Extension Assembly
Part No. 319135**

Ref	Part No	Description
	319135	4' Ladder Extension Assembly, N/S
1	319136	4' Ladder Extension, N/S
2	309880	Adjustable Ladder Support Bar Assembly
3*	311134	Insert Bar (Right)
4*	311135	Insert Bar (Left)
5*	012134	Flat Head Hex Socket Screw, 1/4-20 x 3/4"
Not Shown	011557	Set Screw (For Connecting Extension to Main Ladder)

* Part Of Assembly #1

**Adjustable Ladder Support Bar
Part No. 309880**

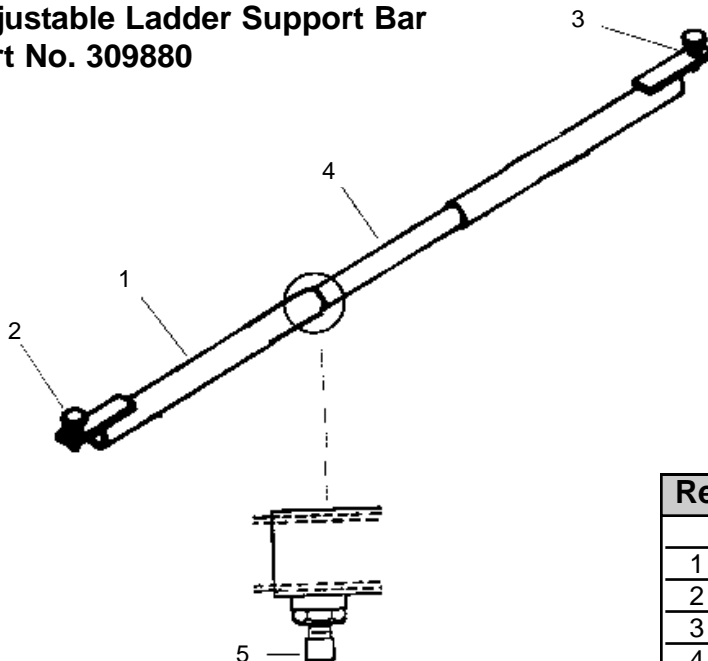

Ref	Part No	Description
	309880	Adjustable Ladder Support Bar Assembly
1	308890	Ladder Support Bar Outside Tube
2	309414	SHCS Assembly, 1/4 x 1 1/4, 1" Knob
3	018069	Hex Nut, 1/4-20, Gr. 8, Plated
4	301884	Inside Tube, Adjustable Ladder
5	011053	SHCS, Black, 1/4-20 x 5/8", Lg.

**Optional
Upper Body Measuring Assembly
Part No. 319625**

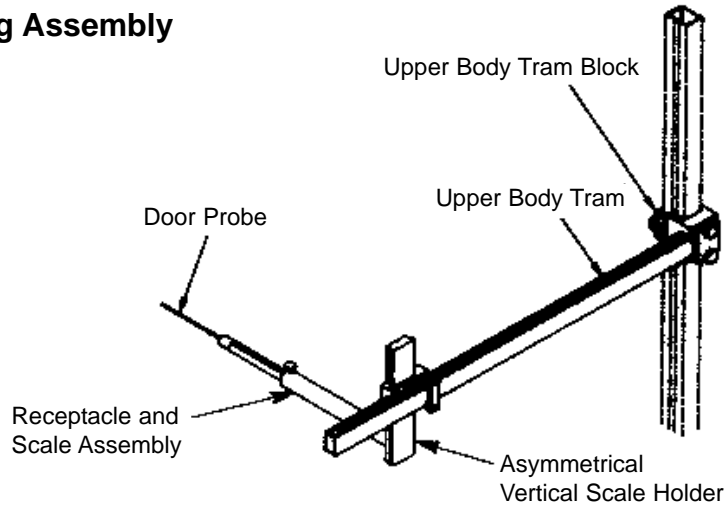

Upper Body Tram Block Assembly

Upper Body Tram Block Assembly (Left)

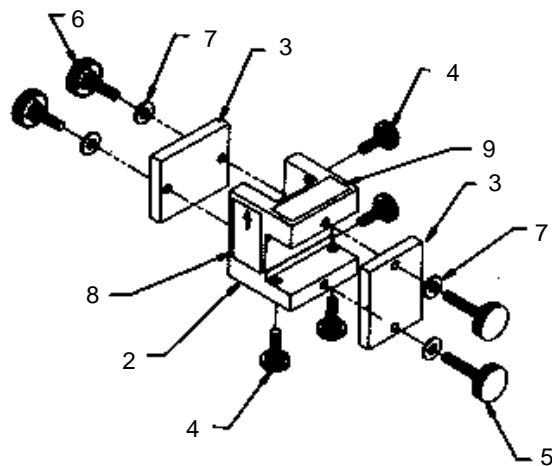
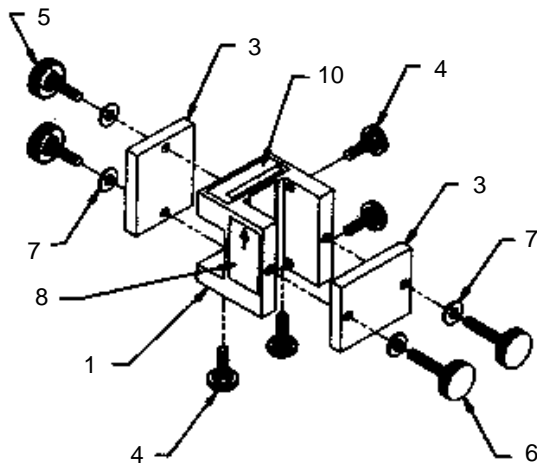

Ref	Part No	Description
	319143	Upper Body Tram Block Assembly, Right Half
	319142	Upper Body Tram Block Assembly, Left Half
1	311623	Upper Body Tram Block, Right Half
2	311624	Upper Body Tram Block, Left Half
3	301308	Plate, BA, 3/8 x 2 1/2 x 2", ALMFLT
4	309411	SHCS Assembly, 1/4 x 3/4 (N); 3/4" Knob
5	309423	SHCS Assembly, 1/4 x 1; 1" Knob
6	309424	SHCS Assembly, 1/4 x 1 1/2; 1" Knob
7	707410	Washer, 1/4", Flat, SAE
8	090711	Decal, "Read At Top"
9	090710	Decal, "Left Side"
10	092420	Decal, Serial Number, UMS Upper Body

Optional
Upper Body Measuring Package (continued)

Vertical Receptacle/Vertical Scale Assembly

Upper Body Tram

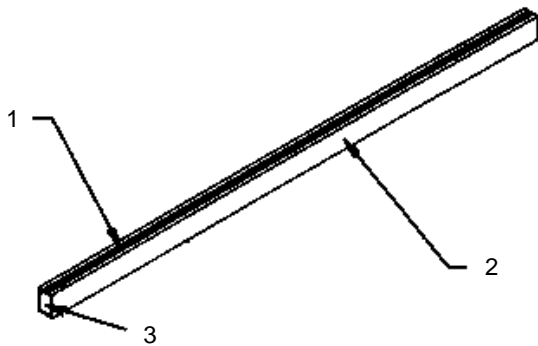

Ref	Part No	Description
	319140	Upper Body Tram
1	311627	Tape, 913mm x 0, 0-913mm, 1/2"
2	301701	Rigid Tram
3	030098	Plug, End, Red

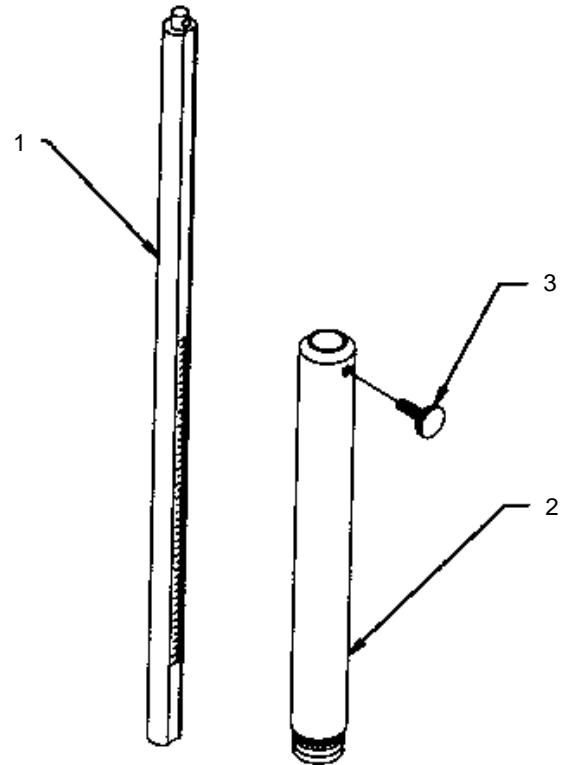

Door Probes

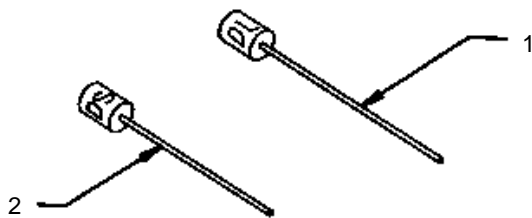

Ref	Part No	Description
1	319101	Door Probe Assembly, Long
2	319102	Door Probe Assembly, Short

Ref	Part No	Description
	319144	Vertical Scale Receptacle/Scale Assembly
1	319141	Scale Assembly
2	309801	Receptacle Assembly
3	309410	SHCS Assembly, 1/2 x 1/2 (N); 3/4" Knob

NOTE: The **Asymmetrical Vertical Scale Holder** provided with the Upper Body Measuring Assembly is shown on Page 14 of this Parts Manual.

Decals

**Part No. 090759
(Includes Nos. 10-21)**

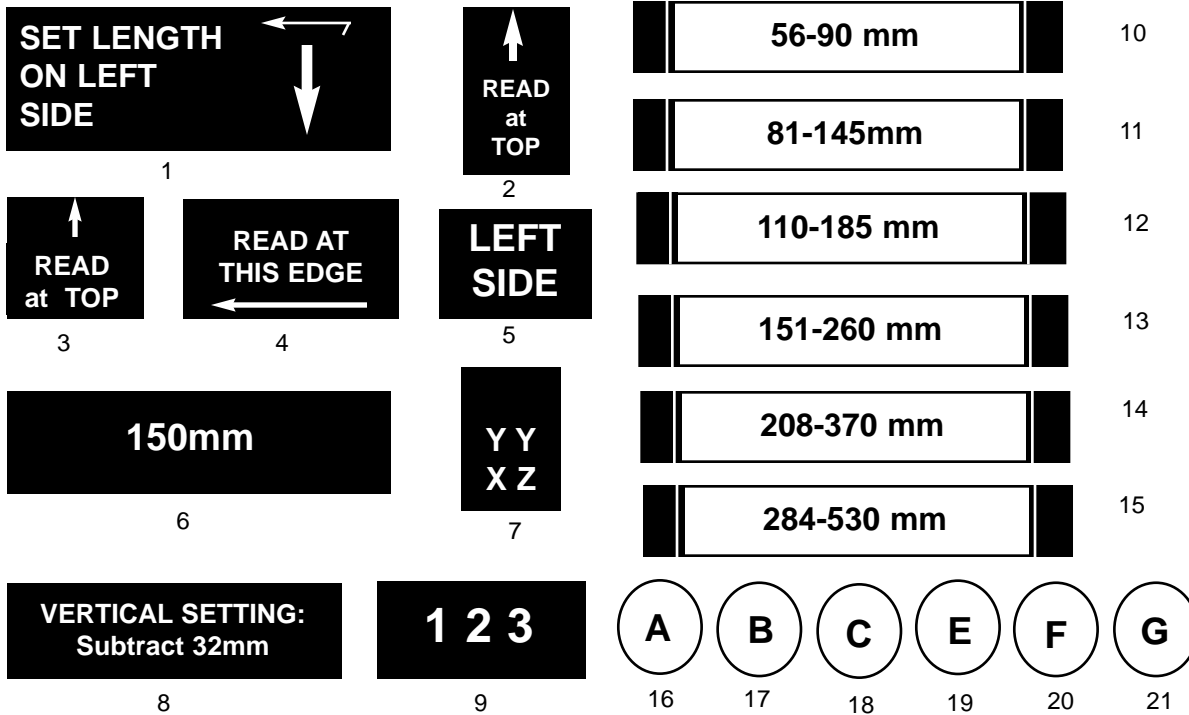

Ref	Part No	Description
1	090793	Decal, "Set Length On Left Side"
2	090711	Decal, "Read At Top"
3	090712	Decal, "Read At Top"
4	090791	Decal, "Read At This Edge"
5	090710	Decal, "Left Side"
6	090709	Decal, "150mm"
7	090730	Decal Set — 228 'X' 'Y' 'Z'
8	090713	Decal, "Vertical Setting"
9	090758	Decal, "Set Ladder Support Bar"
10	090759	Decal, UMS Tool Box



UNIVERSAL MEASURING SYSTEM
PARTS MANUAL

Optional Diagnostic Worksheet (Lower Body/Underhood) (Actual size 8 1/2 x 11 inches)
Part No. 150296

DAMAGE	DATUM			CENTERLINE			LENGTH		
Description	Spec.	Measures	Repair Hours	Spec.	Measures	Repair Hours	Spec.	Measures	Repair Hours
	Rt								
	Lt								
	Rt								
	Lt								
	Rt								
	Lt								
	Rt								
	Lt								
	Rt								
	Lt								
	Rt								
	Lt								
	Rt								
	Lt								
	Rt								
	Lt								
	Rt								
	Lt								
	Rt								
	Lt								
	1	DATUM Sub Total Here		2	CENTERLINE Sub Total Here		3	LENGTH Sub Total Here	
UPPER BODY							TOTAL HOURS (1+2+3)		

Form DW-LB/U 3/93
1993 © Chief Automotive Technologies, Inc.
Part No. 150296



UNIVERSAL MEASURING SYSTEM
PARTS MANUAL

Optional Diagnostic Worksheet (Upper Body)
Part No. 150297

(Actual size 8 1/2 x 11 inches)

DAMAGE		DATUM			CENTERLINE			LENGTH		
Description	Location	Right	Left	Repair Hours	Right	Left	Repair Hours	Right	Left	Repair Hours
		1 DATUM Sub Total			2 CENTERLINE Sub Total			3 LENGTH Sub Total		
								TOTAL HOURS (1+2+3)		

		CAMBER		STRUT		TOTAL		
Comparator Angles		Spec.	Reads	Spec.	Reads	Spec.	Reads	Diagnosis
Front	Rt							
	Lt							
Rear	Rt							
	Lt							
Comments: _____								
Prepared By: _____								

Form DW-UB 3/93
1993 © Chief Automotive Technologies, Inc.
Part No. 150297



P.O. Box 1368
Grand Island, Nebraska 68802-1368
Ph. 308-384-9747
Fax 308-384-8966

www.chiefautomotive.com

**Chief reserves the right to alter product specifications
and/or package components without notice.**