

Chief Universal Measuring System

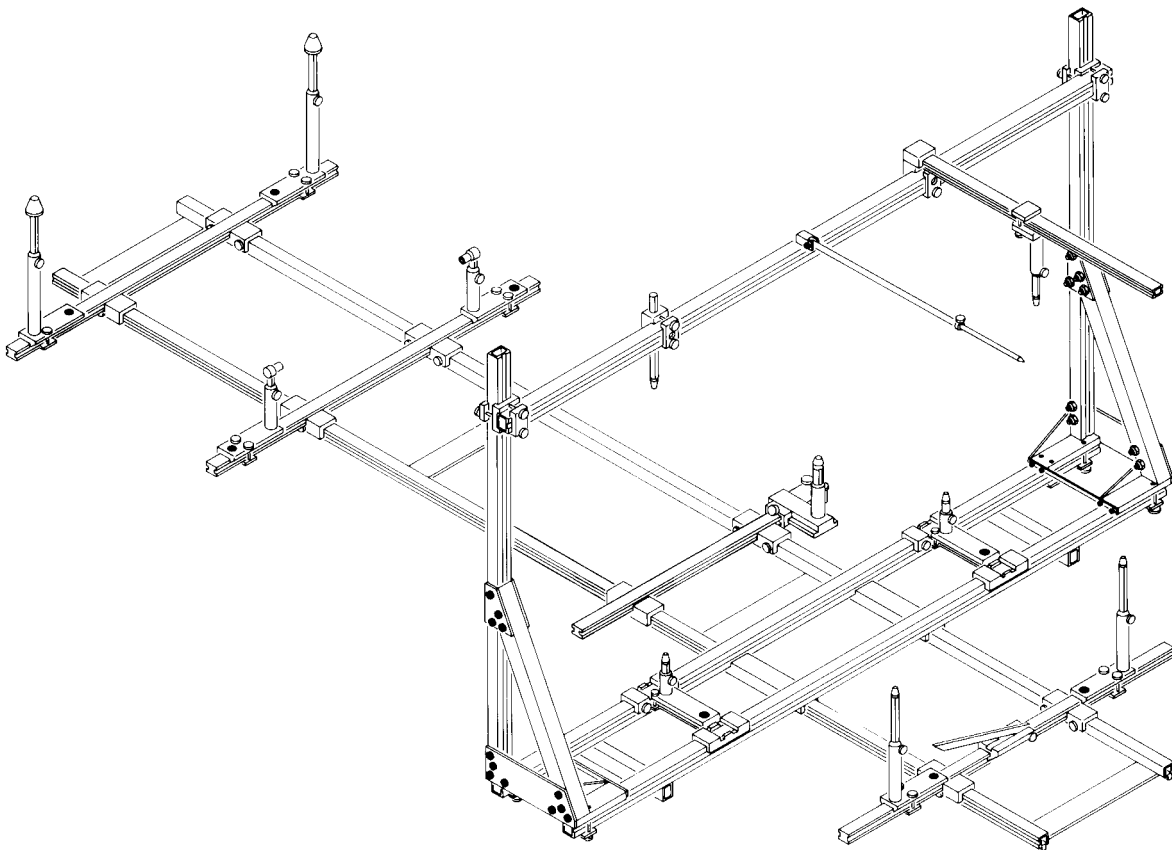

OWNERS MANUAL





CHIEF'S LIMITED ONE-YEAR WARRANTY & LIABILITY

Chief Automotive Technologies, Inc. warrants for one year from date of installation and/or purchase any of its products which do not perform satisfactorily due to defect caused by faulty material or workmanship. Chief's obligation under this warranty is limited to the repair or replacement of products which are defective and which have not been misused, carelessly handled, or defaced by repair or repairs made or attempted by others.

CHIEF AUTOMOTIVE TECHNOLOGIES, INC. DOES NOT ASSUME RESPONSIBILITY FOR ANY DEATH, INJURY OR PROPERTY DAMAGE RESULTING FROM THE OPERATOR'S NEGLIGENCE OR MISUSE OF THIS PRODUCT OR ITS ATTACHMENTS. CHIEF MAKES NO WRITTEN, EXPRESS OR IMPLIED WARRANTY WHATSOEVER OF MERCHANTABILITY OR FITNESS FOR A PARTICULAR PURPOSE OR OTHERWISE REGARDING THE EQUIPMENT OR ANY PART OF THE PRODUCT OTHER THAN THE LIMITED ONE-YEAR WARRANTY STATED ABOVE.

INTRODUCTION

The Chief Universal Measuring System (UMS) is a precision tool that offers unlimited measuring capabilities. It provides a simple yet highly practical technology to auto body repair, one that can be applied to any type of vehicle whether it be of 'unitized body construction' (with or without struts) or 'perimeter frame construction'. It works equally well on pickup trucks, vans and all other utility vehicles.

Once installed, the UMS shows misalignment relating to the vehicle's 'Centerline/Plane' and 'Datum Line/Plane'. (See Figure 1.) The Centerline/Plane is a vertical plane that divides a structure in half lengthwise. It is referred to when determining lateral misalignment. The Datum Line/Plane is a horizontal plane located a specified distance below the structure. It is used when determining vertical misalignment of the end sections of the vehicle.

In addition to measuring the extent of damage, the UMS monitors the repair until correct alignment is

achieved. During corrective pulls, pointers and scales may need to be moved from damage; however, they are easily returned for monitoring and verification of the repair.

In addition to offering step-by-step procedures for setup and usage of UMS equipment (and some optional accessories), this owners manual also provides a detailed explanation of the symbols, codes, and anchoring data that appears in Chief's UMS Data Books. (See Page 12.) Refer also to "PDF" entitled Sample Specification Sheet. For reference purposes there is also a breakdown of UMS Component Terminology. (See Figure 2-Page 2.)

Proper handling and storage of the Chief Universal Measuring system assures prolonged calibration and usefulness of the equipment. It is constructed of high-grade aircraft aluminum and is designed to stand up under conditions normally found in a body shop environment.

CAUTION: 1) Always wear safety glasses when using UMS and its optional accessories.

2) UMS aluminum components will conduct electricity so keep extrusions away from power lines or other sources of electrical output.

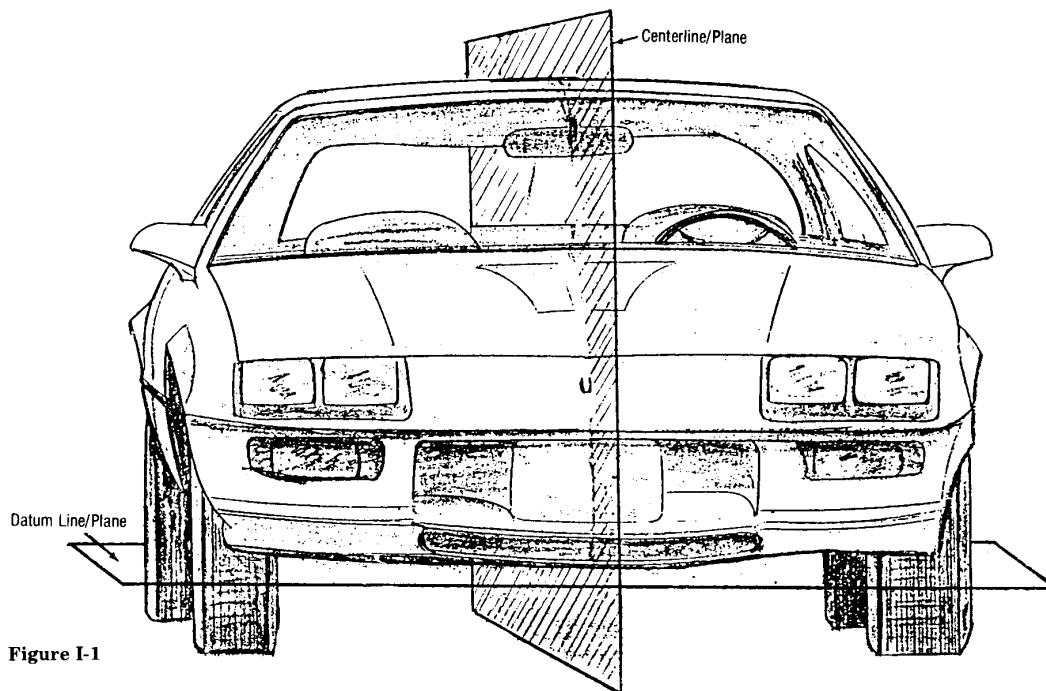
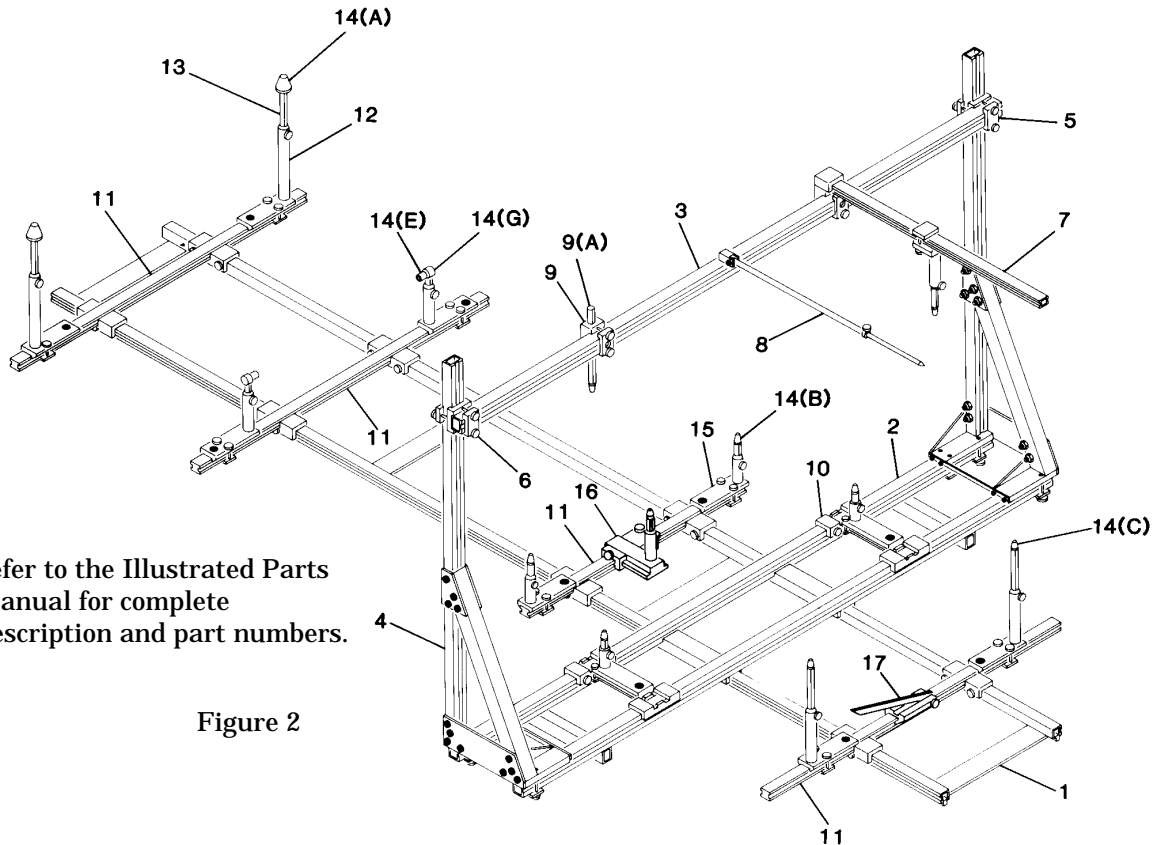

Figure I-1

Figure 1

UMS COMPONENT TERMINOLOGY



NOTE: Refer to the Illustrated Parts Manual for complete description and part numbers.

Figure 2

1. Main Ladder Assembly.
2. Secondary Ladder Assembly (left side identified).
3. Overhead Bar.
4. Vertical Leg Assembly (left side identified).
5. Overhead Bar Mounting Assembly — Left Side.
6. Overhead Bar Mounting Assembly — Right Side.
7. Rigid Tram.
8. Telescoping Tram.
9. Upper Scale Guide Assembly. 9A. Upper Scale Pin.
10. 228mm Datum Bar Assembly — 2.
11. Centerline Bar (left side identified).
 - a) Three 600mm bars with scale holders.
 - b) One 450mm bar with scale holders.
12. Vertical Receptacles. Six different sizes. Receptacle and Scale Assembly (Item 13) only, not to be separated.
13. Vertical Scales.
14. Cones and Fittings:
 - A = Large Cone, 4
 - B = Medium Cone, 8
 - C = Small Cone, 6
 - E = Socket (two each of fourteen sizes from 9mm to 24mm)
 - F = Step Block for measuring pinchwelds, 2
 - G = Right Angle Block, 4
 - H = Vertical Scale Springs, 4
15. Vertical Scale Holder. Note the spacing between the two holes is 150mm. This allows a measurement of more than 600mm. One Centerline Bar is fitted with two single-hole scale holders to accommodate measurements in center area of bar. These single-hole scale holders may be used on any of the Centerline Bars.
16. Asymmetrical Vertical Scale Holder (optional).
17. Ball Joint Locator (optional).

SETTING UP THE MEASURING SYSTEM

1. Select appropriate specification sheet from Data Books.
2. Place main ladder under portion of vehicle to be measured (front or rear). (See Figure 3.)

IMPORTANT: Ladder support bars may be needed when installing the Universal Measuring System aboard some pulling systems. (Check with a Chief Automotive Systems, Inc. representative as per specific applications.) Ladder support bars (see Pages 10 and 11) position the UMS ladder assembly at the correct height relative to the anchoring equipment being used.

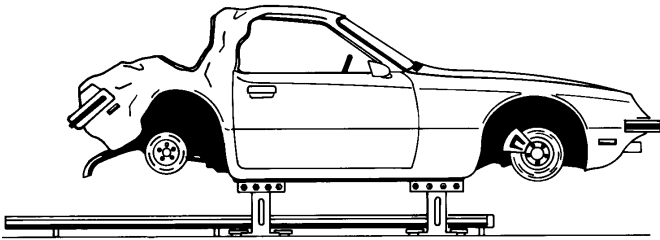

Figure 3

3. Select two centerline bars (see Figure 4) and secure vertical scale holders at prescribed left side and right side centerline dimensions.

IMPORTANT: Prescribed centerline dimensions are noted on the specification sheet — see (X) locations — control points. The two centerline bars noted in this step will be the first two attached to the main ladder. If more than one of the four control points (X) has sustained damage, select another point for installation purposes. The centerline bar(s) can be returned to the control points (X) after the damage has been corrected.

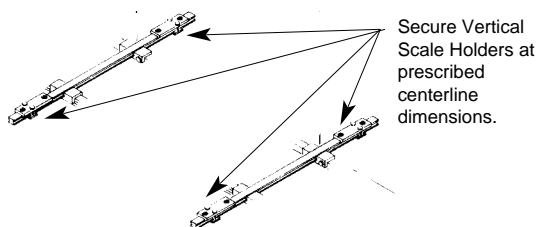



Figure 4

4. Refer to specifications sheet's  or  symbols at the control points (X). Select appropriate vertical receptacles, vertical scales and fittings, and insert them into the holders. For these centerline bars **only**, remove vertical scale pins from the tubes and insert a coil spring. Reinsert and compress pins.

CAUTION: DO NOT loosen screw knobs as this will discharge vertical scale pins.

5. Position one centerline bar under the vehicle at its designated control points (X).

IMPORTANT: One side of each centerline bar assembly is labeled 'left side'. This side **MUST BE** positioned on main ladder directly below left side of vehicle.

6. Shift main ladder and centerline bar until fitting aligns with designated control point (X) on vehicle. Loosen knob that secures vertical scale and fitting and adjust these components until fitting seats firmly with vehicle. **DO NOT** retighten the knob as spring-loaded scale will hold fitting in place. Move to other side of vehicle and repeat the procedure.

NOTE: Due to the automobile manufacturing tolerances, centerline dimensions may vary slightly from vehicle to vehicle. If fitting on opposite side of vehicle does not align at its designated control point (X), loosen vertical scale holder on that side of vehicle and slide it until fitting does fit. Note difference between centerline dimensions and change each side one-half of the difference. For example: If vehicle is 2mm wider than specification sheet calls for, widen each side of centerline bar scale by 1mm.

7. Repeat Steps 5 and 6 for second centerline bar.
8. Tighten knobs securing centerline bars to main ladder, left side first. The main ladder is now squared to the vehicle.

NOTE: In extreme cases, centerline dimensions may vary considerably from specification sheet, and it may be desirable to place a third centerline bar at another position to verify correct position of main ladder in relation to true centerline of vehicle.

9. Install additional centerline bars (following Steps 3 and 4) for measuring other points under the vehicle.

10. Length measurements are accomplished with sliding tapes located on both sides of main ladder. When taking a length measurement at rear of vehicle, set zero point of left side tape at scribe line of front centerline bar and read length at scribe lines of centerline bars at rear of vehicle. When taking a length measurement at front of vehicle, set zero point of left side tape at scribe line of rear centerline bar and read length at scribe lines of centerline bars at front of vehicle.

- NOTE:** 1) When reading length on right side of vehicle, follow same procedures; however, refer to rear edge of centerline bar guides instead of scribe lines.
- 2) Due to automobile manufacturing tolerances, length between control points may vary slightly from vehicle to vehicle. Generally, any deviation of length found in this area should be carried out through rest of vehicle. For example: If vehicle is 4mm longer than data sheet calls for between control points, add 4mm to remainder of length dimensions.

11. All length measurements to secondary ladder must be done on left side. Set tape on main ladder to length indicated by . This number appears under scribe line of centerline bar at rear control point.

12. Position secondary ladder on main ladder with scribe line over zero point of tape. (See Figure 5.)

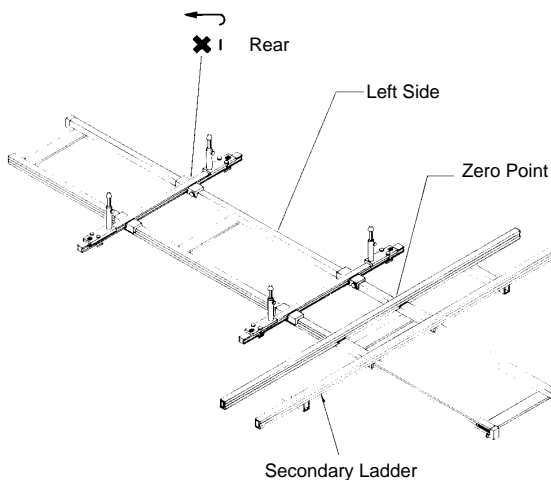



Figure 5

13. Adjust overhead bar mountings on vertical legs to setting inside this symbol . (See Figure 6.) For example: .

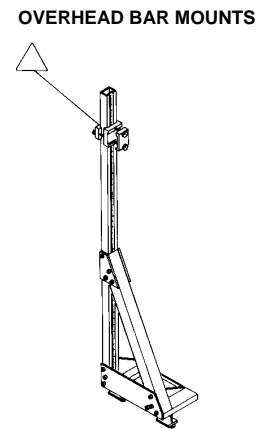

Figure 6

14. Slide vertical legs onto secondary ladder and slide to the 'stops'. Tighten vertical legs to secondary ladder. (See Figure 7.)

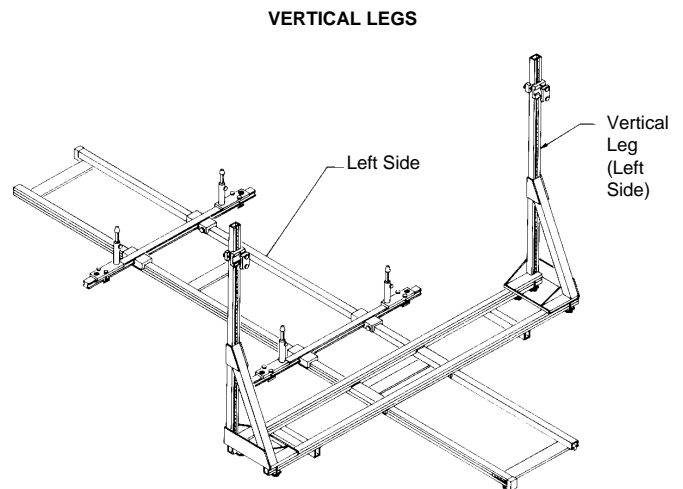

Figure 7

15. To install overhead bar, slide bar into left side mounting (spring loaded) to the 'stop'. (See Figure 8.) Attach overhead bar to right side mounting using 'captured screws' on bar assembly.

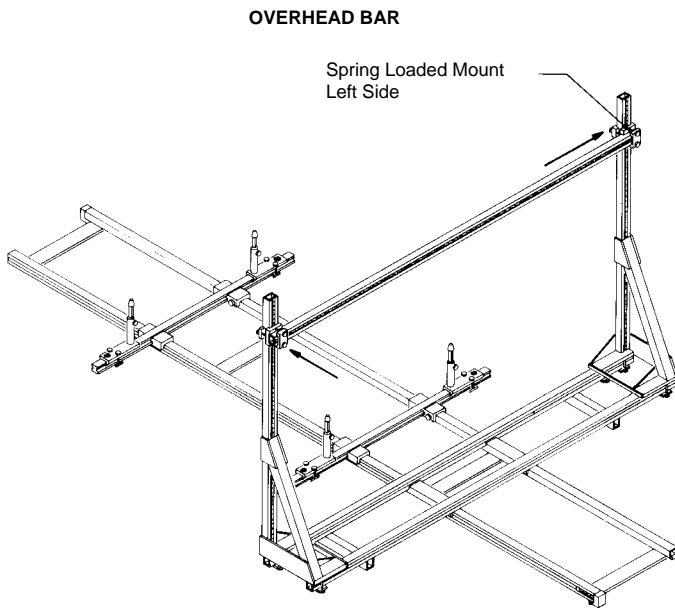

Figure 8

16. Adjust upper scale guides to centerline dimensions. (Directly above \triangle symbol on specification sheet.) (See Figure 9.)

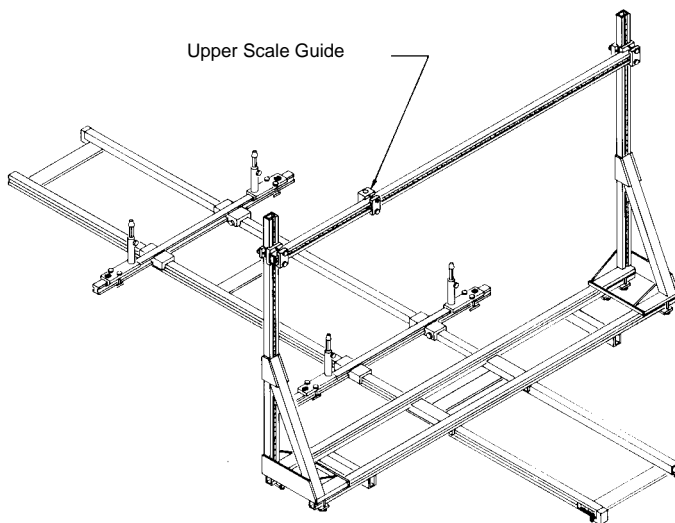

Figure 9

17. Insert upper scale pins into upper scale guides. Use the fitting designated in the ∇ symbol. The number in this symbol is the vertical dimension at these positions.

18. Position fittings firmly to vehicle. Then, tightening left side first, secure secondary ladder to main ladder.

19. Most underhood points which are forward of the overhead bar are measured with rigid tram. To use rigid tram, remove one of the upper scale pins. Insert pin on rigid tram into upper scale guide and tighten screw knob on back side of guide. (See Figure 10.)

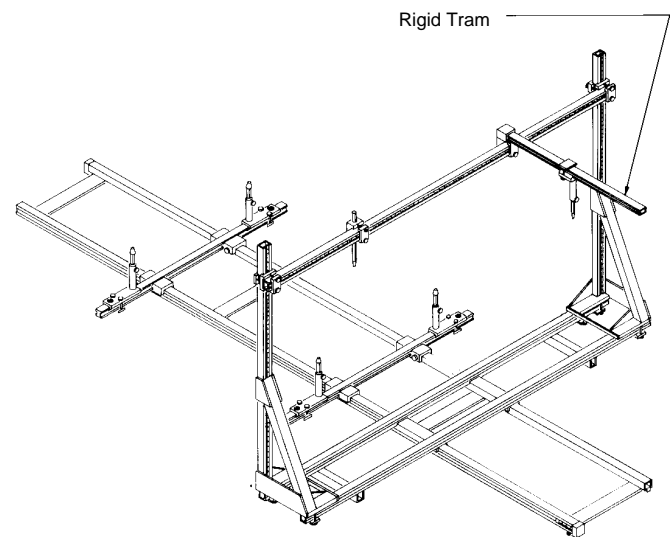

Figure 10

20. Adjust upper scale guide to prescribed centerline dimension.

21. Adjust vertical scale holder on rigid tram to prescribed length.

22. Using same procedure that is used under the vehicle, select appropriate vertical scale receptacle, vertical scale and fitting and insert into vertical scale holder. Lower fitting to vehicle.

NOTE: Whenever possible, leave one of the overhead bar's upper scale pins in contact with vehicle. This helps to maintain rigidity of upper system.

23. To measure opposite side of vehicle, remove upper scale pin from the other guide. Position guide at proper centerline dimension and insert rigid tram into the block.

24. The UMS also features a telescoping tram that attaches to hole in center of overhead bar. It may be used to check upper body structure for symmetry. (See Figure 11.)

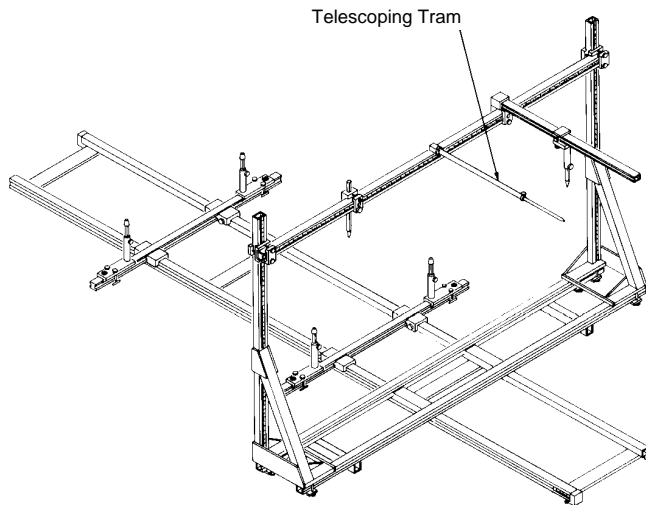







Figure 11

UNDERHOOD MEASURING

1. Referencing tape on left side, position secondary ladder on main ladder with scribe line over length indicated by . Tighten left side first when securing secondary ladder to main ladder.
2. Repeat Steps 13 through 16 — Pages 4 and 5.
3. Note direction of arrow  or  under  symbol. Insert upper scale pins into upper scale guides in direction indicated by arrow, use fitting called for in this symbol. The number in this symbol is vertical dimension (always read at top of scale guide) at these positions.
4. Use rigid tram to measure all points that are forward of overhead bar. Length settings for vertical scale holder on rigid tram  are located just below vehicle drawing.



UPPER BODY MEASURING

The components of the Universal Measuring System can be used to take comparison measurements of some upper body locations. For example: overhead bar may be passed over or through body of vehicle to measure roof, hinge posts, latch posts, windshield openings, etc.; or, overhead bar may be bridged over rear of vehicle where rigid tram and telescoping tram can be used to measure rear gate or hatchback openings or interior structural components such as rear strut towers or package shelves.

Although UMS components can be used to reach and measure such upper body locations, Chief recommends the use of its Upper Body Measuring Package. The equipment in this package extends the UMS capabilities allowing for a greater range of upper body measuring. The package also includes a full line of upper body specifications.

228MM DATUM BAR/DATA CHART

The 228mm Datum Bar is designed for the UMS secondary ladder. The 228mm Bar measures points that are otherwise inaccessible when using the secondary ladder. (See Figure 12 — Page 7.)

The 228mm Bar Data Chart (see Figure 13) is located in lower left corner of specification sheet. The 228mm Bar has receptacle holes labeled 'X', 'Y', and 'Z'. (See labeling instructions to convert former 228mm Bars to the 'X', 'Y', 'Z' format.) The 228mm Bar Data Chart has five columns: Position, Receptacle, Length,  Vertical, and  Vertical.

The 'X' 'Y' 'Z' 228mm Bars, and the 'X' 'Y' 'Z' 228mm Bar Data Chart eliminates calculations and conversions by technicians. To use, simply set the bars and vertical scales according to specifications in the 228mm Bar Data Chart.

Each position number on the 228mm Bar Data Chart correlates with the same position number on the underbody portion of the specification sheet. To use the 228mm Datum Bar and Chart, refer to Figure 13 (Page 7) and read Examples 'X', 'Y', and 'Z' (Page 8).

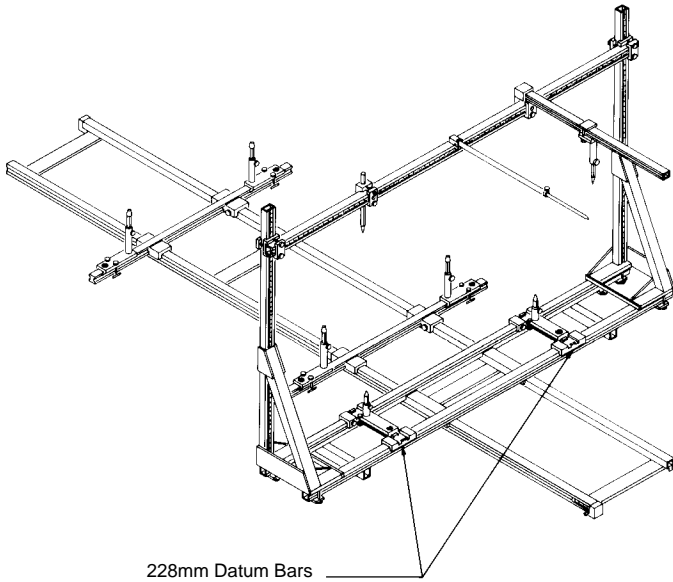

228mm Datum Bars

Figure 12

228mm Datum Bar Adjusted Settings

Pos.	Recpt.	Lg.	Vert.	Vert.
11	X	150		B 344
12	X	149 G	E12 177	
13	Y	98		B 142
14	Y	95 G	E22 180	
15	Z	102 G	E22 177	
16A	Z	135 G	E15 352	
16B	Z	68 G	E15 480	

SAMPLE SPECIFICATION SHEET

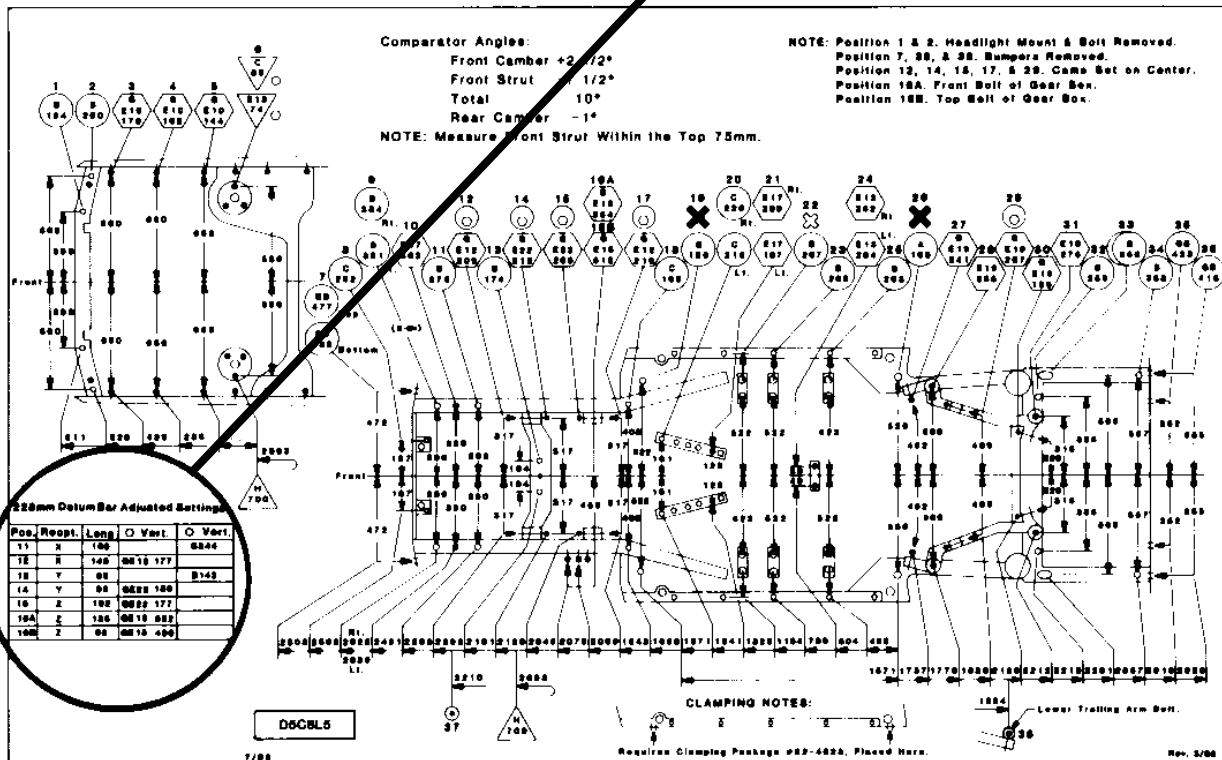

MB-11

Figure 13

Example X

(Refer to Figure 13-Page 7 and Figure 14 below.)

1. a) Select position number to be measured. (For example: Position No. 11.)
- b) Set scribe line (under Y) at designated length (150mm). (See Figure 14.)
- c) Select vertical scale designated in vertical column (334). In this instance, the 284-530 scale is appropriate.
- d) Insert vertical scale into 'X' receptacle hole (toward front of vehicle) using a B cone.
- e) Centerline is read at scribe line on front of 228mm Bar.

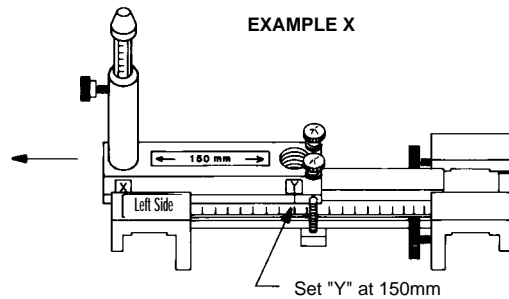

Figure 14

Example Z

(Refer to Figure 13-Page 7 and Figure 16 below.)

2. a) Select position number to be measured. (For example: Position No. 16.)
- b) To measure to 'Z' position, remove scale holder from 228mm Bar and rotate one-half turn. Set scribe line under Y at length designated (135mm). (See Figure 16.)
- c) Select vertical scale designated in vertical column (352mm).
- d) Insert vertical scale into Z receptacle hole (toward rear of vehicle) using a 15mm socket.
- e) Centerline is read at scribe line on front of 228mm Bar.

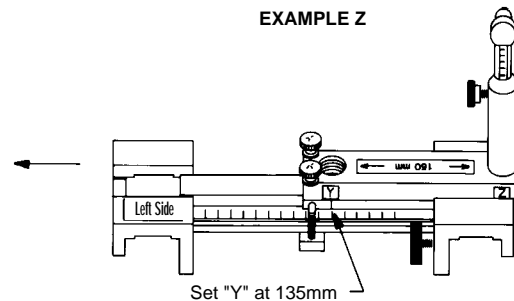

Figure 16

Example Y

(Refer to Figure 13-Page 7 and Figure 15 below.)

2. a) Select position number to be measured. (For example: Position No. 13.)
- b) Set scribe line (under Y) at designated length (98mm). (See Figure 15.)
- c) Select vertical scale designated in vertical column (142mm).
- d) Insert vertical scale into Y receptacle hole using a B cone.
- e) Centerline is read at scribe line on front of 228mm Bar.

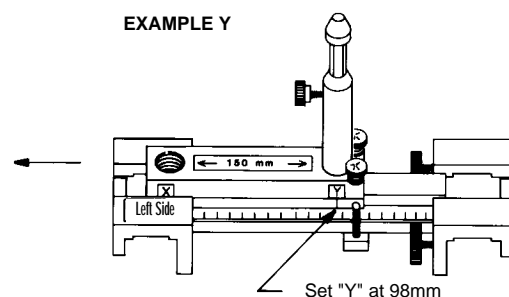

Figure 15

Length is always set at scribe line labeled 'Y'.
'X' dimensions are measured with vertical scale in receptacle hole labeled 'X' (toward front of vehicle).
'Y' dimensions are measured with vertical scale in receptacle hole labeled 'Y' (toward front of vehicle).
'Z' dimensions are measured with vertical scale in receptacle hole labeled 'Z' (toward rear of vehicle).

NOTE: 1) Vertical dimensions designated in 228mm Bar Data Chart have taken into consideration the 32mm height difference which exists when using 228mm Bars. (No calculations are necessary and vertical scale should read as per 228mm Bar Data Chart.)

2) Centerline dimensions remain unchanged. They are the same as when using a centerline bar.

LADDER SUPPORT BARS

Ladder support bars may be needed when installing the UMS ladder assembly aboard some pulling systems. (Check with a Chief Automotive Systems, Inc. representative as per specific applications.) Ladder support bars position the UMS ladder assembly at the correct height relative to the anchoring equipment being used.

When using ladder support bars, follow these procedures:

1. Retract the screws on the ladder support bars so that each screw is flush with bottom of ladder-support bar flange.
2. Apply decals 1, 2, and 3 to ladder support bars, one decal per bar. (See Figure 17.)

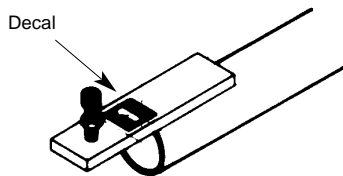

Figure 17

3. Place three ladder support bars on pulling system rack. The No. 1 bar should be placed at front of rack with decal on left side of vehicle. (See Figure 18.)

NOTE: A fourth ladder support bar should be used when the 4-foot ladder extension (optional accessory — see Page 11) is being used.

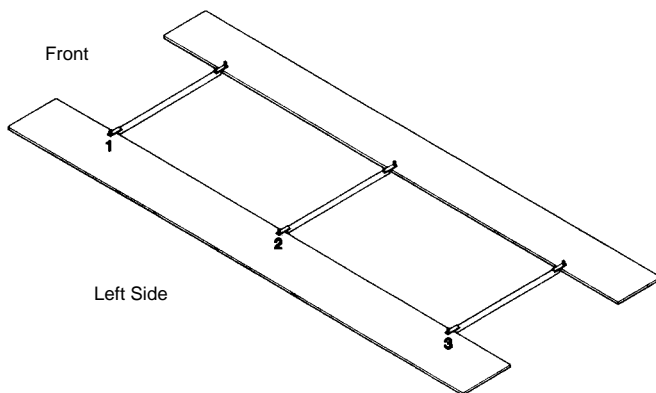

Figure 18

4. Place second set of decals on rack matching the numbers on ladder support bars. (See Figure 19.)

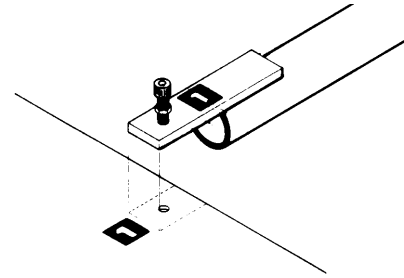

Figure 19

5. Place ladder assembly on ladder support bars. (See Figure 20.)

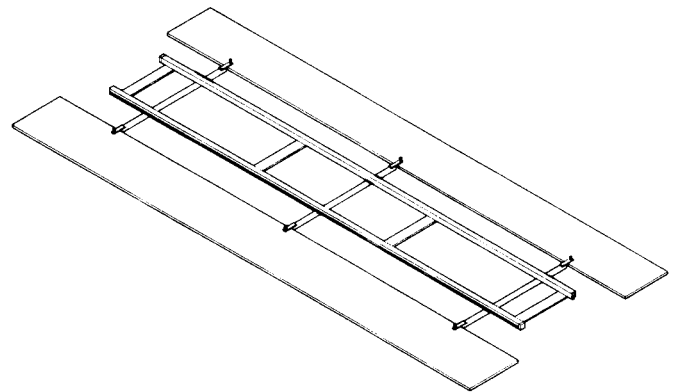

Figure 20

6. Place two pinchweld clamp stands on the rack, centered with the No. 2 bar. (See Figure 21.)

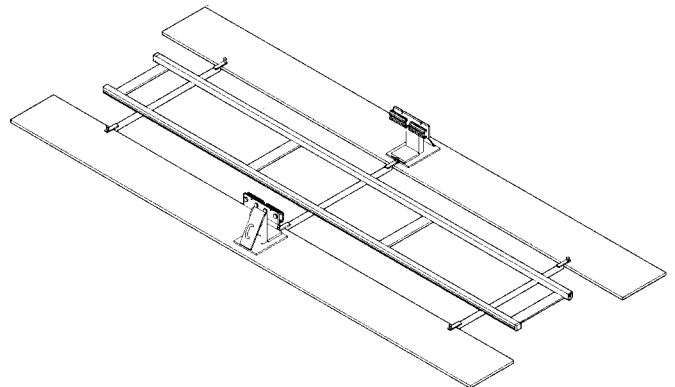

Figure 21

7. Using a centerline bar (48 inch), set two vertical scale holders at a centerline of 500mm. Install a 150-260mm vertical scale, fitted with a 'C' cone, in each of the vertical scale holders. Set both vertical scales at 176mm. Place centerline bar as close to the No. 2 ladder support bar as possible, leaving enough room to adjust the bar. (See Figure 22 on Page 10.)

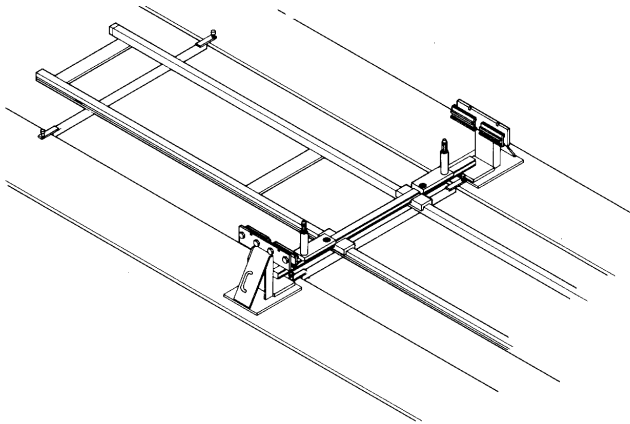

Figure 22

8. Place overhead bar across top of clamps, directly over 'C' cones. (See Figure 23.)

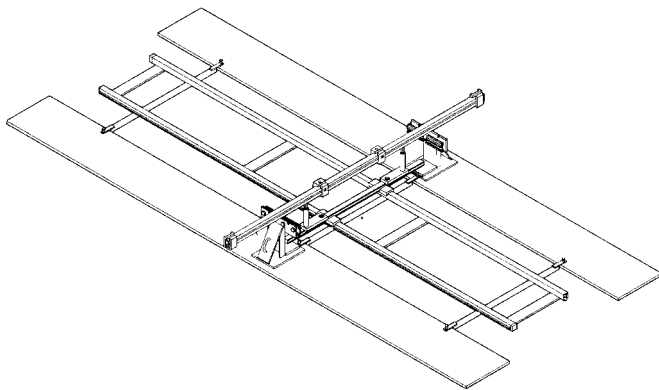

Figure 23

9. Adjust No. 2 ladder support bar screws until both right and left 'C' cones are making contact with bottom of overhead bar.
10. Repeat Steps 6-9 at ladder support bars No. 1 and No. 3.
11. After all three ladder support bars have been adjusted, check main ladder to be sure it is resting upon support bars. Then tighten jam nuts on each of the adjustment screws.
12. Place ladder support bars in the same position every time UMS is to be used on this rack.

UMS SUGGESTIONS

- UMS is a calibrated precision instrument machined and manufactured for easy operation. DO NOT use force when assembling or moving UMS parts.
 - Unless there is collision damage at control points (X), UMS may remain in contact with these points at all times. Spring-loaded scales secure fittings to the control points (X).
 - During corrective pulls, disengage UMS components from damaged areas of vehicle.
 - Upon completion of repairs, dismantle UMS, and return its components to the storage rack. Proper handling and storage of UMS components will assure prolonged calibration and usefulness of the equipment.
- ⚠ CAUTION:** When installing or dismantling UMS, handle spring-loaded scales carefully. Remove springs from scales when dismantling system.
- DO NOT tamper with any UMS screws.
NOTE: This does not apply to top front screw on upper scale guide nor to screws that are fitted with knobs.
 - When welding or using cutting-torch near UMS, protect UMS components from sparks and slag!
 - Although UMS has an anodized finish, some chemicals (such as battery acid) may be harmful to the finish.
 - Diagnostic worksheets for 'lower body/underhood' (Part No. 150296) and 'upper body' (Part No. 150297) are available from Chief Automotive Systems, Inc., 800-445-9262.

ASYMMETRICAL VERTICAL SCALE HOLDER (OPTIONAL ACCESSORY)

Asymmetrical vertical scale holder is used when corresponding right and left dimensions are asymmetrical at a given position (within 100mm). (See Figure 24.)

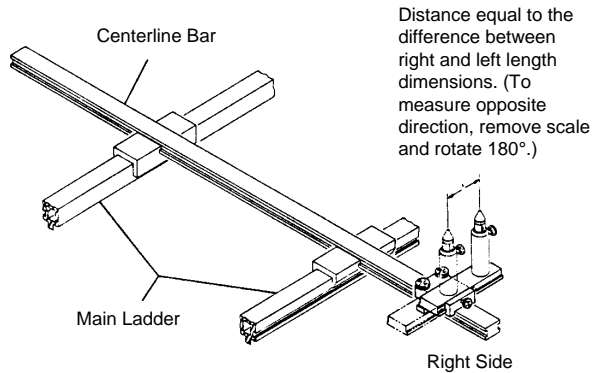

Figure 24

1. Position centerline bar on main ladder at length specified for left side.
2. Place asymmetrical holder on right side of centerline bar as shown in Figure 24.
3. Position asymmetrical holder at specified centerline dimension and clamp in place.
4. Slide scale forward or rearward a distance equal to the difference between right and left length dimensions. (To measure opposite direction, remove scale and rotate 180°.)
5. Tighten knob to hold scale at desired dimension.

BALL JOINT LOCATOR (OPTIONAL ACCESSORY)

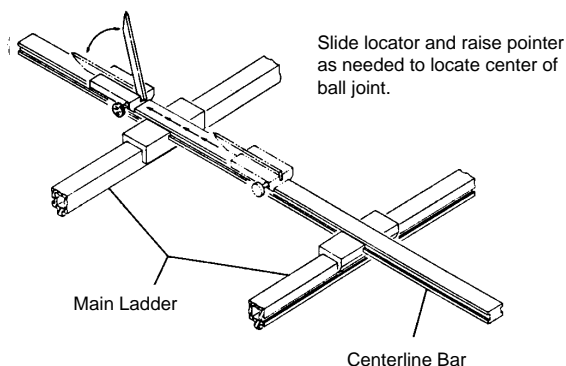

Figure 25

1. Work on side of vehicle with least damage first.
2. Position centerline bar at length indicated on data sheet. The symbol $\frac{205}{\phi}$ indicates length from rear zero point to center of ball joint.
3. Place ball joint locator on centerline bar. (See Figure 25.)
4. Slide locator and raise pointer as needed to locate center of ball joint.
5. Tighten knob to hold pointer in place while moving locator to opposite side of vehicle.
6. Compare location of ball joints.

4-FOOT LADDER EXTENSION (OPTIONAL ACCESSORY)

The 4-foot ladder extension provides greater flexibility in regard to length measurements. Existing UMS measuring tapes extend onto its extrusions making it possible to measure the entire length of most vehicles.

1. Remove flat head socket screws from inserts and slide inserts into extrusions of 4-foot ladder extension. Then align holes in insert with pre-drilled holes in extrusions and reinsert the screws. (See Figure 26.) DO NOT tighten the screws at this time.

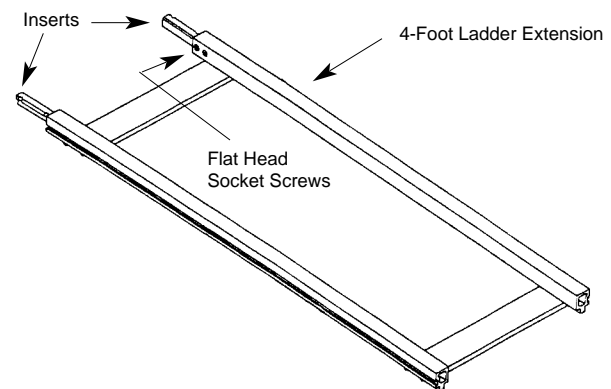

Figure 26

2. Slide measuring tapes away from plastic caps at ends of main ladder extrusions. This exposes four flat head socket screws (two per extrusion). Retract the screws and remove the plastic caps.
3. Connect the assemblies by sliding the inserts (notched ends) into the main ladder extrusions. Then retighten the flat head socket screws on the main ladder and 4-foot extension. Reinstall plastic caps at far end of 4-foot ladder extension.

EXPLANATION OF SYMBOLS — UMS SPECIFICATION SHEET

NOTE: 1) Refer to UMS specification sheets and to “PDF” entitled Sample Specification Sheet.

2) Left side is always at bottom of specification sheet, and front of vehicle is to left of specification sheet.

a) Centerline dimensions are found in center areas of vehicle drawings. Always check left side and right side dimensions.

NOTE: A  symbol indicates centerline dimension which is greater than the length of the centerline bar. When this symbol appears, insert vertical scale receptacle in **outer** hole of vertical scale holder and adjust vertical scale holder to prescribed centerline dimension using **inner** scribe line.

b) A circle  indicates measurement to a hole.



c) A hex  indicates measurement to a bolt.

d) A square  indicates use of ‘F’ block to measure to an edge.

e) If both circle and hex are shown at same point, hex is for measuring to bolt (with part installed), and circle is for measuring to bolt hole (with part removed).

f) A hole is indicated by a circle ‘’.

g) A bolt is indicated by a ‘’ or ‘’.





h) The bottom number in circle  or hex  is vertical dimension. This number also indicates size of vertical scale to be used. For example:  requires use of 110-185mm scale.

i) Letter at top of circle or hex designates fitting to be used on vertical scale. An ‘E’ (socket) is followed by a number designating size of socket. A ‘G’ (right angle block) is followed by another letter designating fitting to be used on right angle block.

j) **X’s** indicate preferred positions to place first two centerline bars which square system to vehicle.

k) The first two centerline bars become ‘0mm’ reference points for length dimensions. The front bar scribe line is zero point for measuring length at rear of vehicle using tape on left side. The rear bar scribe line is zero point for measuring length at front of vehicle using tape on left side.



NOTE: When reading length on right side, follow same procedures; however, refer to rear edge of centerline bar guides instead of scribe lines.



l) A pair of brackets () found in line connecting vertical scale symbols    to vehicle drawing indicates use and setting of asymmetrical scale holder (optional accessory — see Page 11). (Asymmetrical scale holder is used only on passenger side under vehicle.)

m) The  symbol indicates use of ball joint locator (optional accessory — see Page 11), usually indicating length to center of ball joint from rear zero point. (It may also indicate other dimensions which are measured with ball joint locator.)

NOTE: For letters n-r, refer to underhood drawing on sample specification sheet.

n) The  symbol is length setting from rear zero point for placement of secondary ladder.

o) The number in  symbol shows vertical setting for overhead bar mountings on vertical legs. For example: .

p) The  symbol indicates vertical dimension of upper scale pin and fitting to be used. For example: .

q) The numbers indicated on horizontal line underhood drawings indicate length settings for scale holder on rigid tram.

r) A circle and hex located above underhood drawings, control vertical dimensions and fitting requirements for vertical scale used on rigid tram.

EXPLANATION OF CODE BOX

NOTE: Refer to “PDF” entitled Sample Specification Sheet.

The following explanation of the Code Box (which appears on all UMS Specification Sheets) is based on measurements obtained in the Chief Automotive Systems, Inc. Research Facility. The purpose of codes is to help technicians isolate collision damage from normal vehicle-to-vehicle dimensional variations. (See sample Code Box — Figure 27.)

D = Number following ‘D’ indicates most extreme deviation found in datum (vertical) dimensions.

For example: If greatest variation in datum exists at position No. 25 (observed dimensions vary from 200mm to 205mm) dimension listed on specification sheet will be an average of the two dimensions (202.5mm). Therefore, a code of D5 indicates a datum variation of no greater than plus or minus 2.5mm was found to exist throughout entire vehicle.

C = Number following ‘C’ indicates most extreme deviation found in centerline dimensions.

L = Number following ‘L’ indicates most extreme deviation found in length dimensions.

**D5C7L8**

Figure 27

ANCHORING INFORMATION

Many of the specification sheets in UMS Data Books feature important ‘anchoring’ information. Chief’s UMS pinchweld stands (with special adapters); Universal Anchoring Stands (with UMS adapter tubes and special adapters); and, Universal Holding System (with special adapters) not only secure a vehicle to a variety of pulling systems, but also position the vehicle at the prescribed height for using this measuring system. Use the following guidelines to ensure correct placement of anchoring equipment.

- 1) Locate specification sheet for vehicle to be measured and inspect it for special clamping instructions. Special clamping instructions are located at bottom of specification sheet and/or on back of specification sheet.
 - If special instructions are indicated, follow procedures indicated on specification sheet.
 - If special instructions are not indicated, position anchoring clamps at ends of rocker panels and proceed with Steps 2-7.
- 2) Inspect the inside of pinchwelds for fuel lines, brake lines, or other items which may interfere with placement of clamps. Remove undercoating from pinchweld.
- 3) Work on one side of vehicle at a time starting with least damaged side first. Raise vehicle high enough to remove wheels and place clamps under the pinchweld.
- 4) Lower vehicle until rocker panel pinchweld fits into clamps.

IMPORTANT: Bottom surface of rocker panel **MUST BE** firmly against top surface of clamps.
- 5) Tighten clamp jaw bolts. (Torque to 100 ft. lbs. maximum.)
- 6) Tighten clamp mounting bolts.
- 7) Repeat Steps 2-6 on opposite side of vehicle.

ANCHORING HEIGHT ADJUSTMENTS (IF NEEDED)

Install Universal Measuring System (UMS) as per its specification sheet and measure height of four base reference points in vehicle's center section. Then compare measurements of both front and rear points with their specifications. (See example - Figure 28.)

NOTE: If diamond or twist exist in center section, follow prescribed procedures for measuring and correcting.

<u>Center Section Base Reference Points</u>			
	Actual Measurements	Specifications	Difference
<u>Front</u>	300mm	280mm	+ 20mm
<u>Rear</u>	420mm	390mm	+ 30mm

Figure 28

To use UMS successfully, the difference between actual measurements and specifications must be identical (or nearly identical) from front of center section to rear. To adjust the vehicle referenced in Figure 28, a technician could try one of the following:

- Elevate front anchoring location 10mm to create a difference of +30mm at both front and rear.
- Lower rear anchoring location 10mm to create a difference of +20mm at both front and rear.
- Elevate front anchoring location 5mm and lower rear anchoring location 5mm to create a difference of +25mm at both front and rear.

NOTE: Height adjustments techniques will vary dependent upon anchoring equipment used.

Once differences are equal from front of center section to rear, all other datum height measurements can be gathered and adjusted by the same amount.

NOTE: If it is impossible to match the front and rear differences, get them as close as possible and then average the resulting numbers. (See example - Figure 29.) In this example, all other datum height measurements would then be adjusted by 23mm.

<u>Center Section Base Reference Points</u>			
	Actual Measurements	Specifications	Differences
<u>Front</u>	300mm	280mm	+ 20mm
<u>Rear</u>	420mm	394mm	+ 26mm
		<u>average</u>	+23mm

Figure 29

The amount of deflection in a vehicle's end section will vary dependent upon anchoring locations selected. Although the amount of this deflection can not be predetermined, it will be equal one side of vehicle to the other. For example: If amount of deflection is 12mm on both sides of rear section, and there are no visual indications of damage, the deflection is likely due to anchoring.

NOTE: Chief specifications are obtained from vehicles that are anchored at specific points and at specific heights which unload the suspension.



P.O. Box 1368
Grand Island, Nebraska 68802-1368
308-384-9747

**Chief reserves the right to alter product specifications
and/or package components without notice.**