

UMS Storage Rack

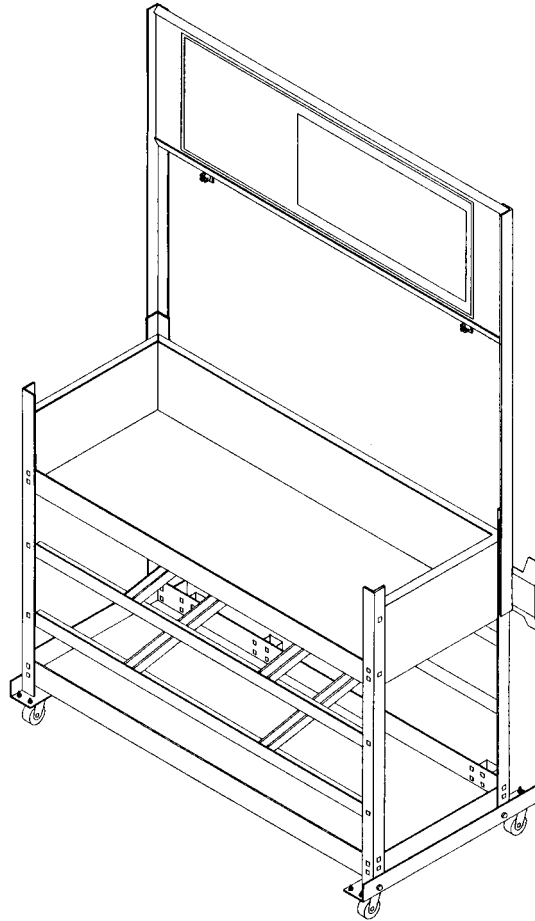

ASSEMBLY INSTRUCTIONS





CHIEF'S LIMITED ONE-YEAR WARRANTY & LIABILITY

Chief Automotive Technologies, Inc. warrants for one year from date of installation and/or purchase any of its products which do not perform satisfactorily due to defect caused by faulty material or workmanship. Chief's obligation under this warranty is limited to the repair or replacement of products which are defective and which have not been misused, carelessly handled, or defaced by repair or repairs made or attempted by others.

CHIEF AUTOMOTIVE TECHNOLOGIES, INC. DOES NOT ASSUME RESPONSIBILITY FOR ANY DEATH, INJURY OR PROPERTY DAMAGE RESULTING FROM THE OPERATOR'S NEGLIGENCE OR MISUSE OF THIS PRODUCT OR ITS ATTACHMENTS. CHIEF MAKES NO WRITTEN, EXPRESS OR IMPLIED WARRANTY WHATSOEVER OF MERCHANTABILITY OR FITNESS FOR A PARTICULAR PURPOSE OR OTHERWISE REGARDING THE EQUIPMENT OR ANY PART OF THE PRODUCT OTHER THAN THE LIMITED ONE-YEAR WARRANTY STATED ABOVE.

COMPONENT TERMINOLOGY

Not shown:

- Tool Box
- Bar clamps (on back of lower sign brace).

UMS STORAGE RACK

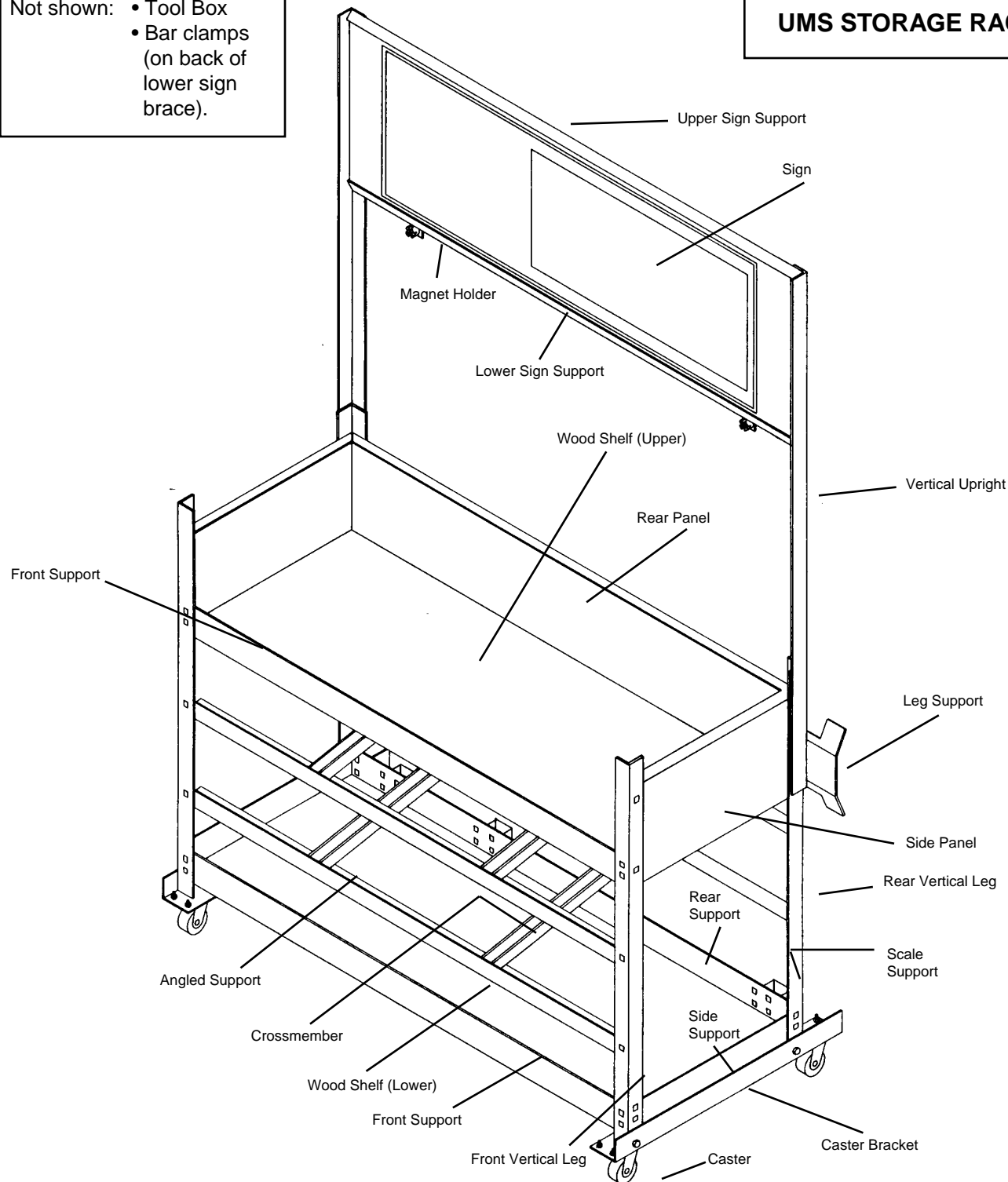

ASSEMBLY INSTRUCTIONS

The Universal Measuring System Storage Rack is easily assembled as the majority of pieces snap together by means of inter-locking tabs. A rubber hammer (and wood block) is generally sufficient for tapping pieces together. In addition, a flathead screwdriver and the following wrenches are needed for installing some components: 1/4" (6.4mm) and 5/16" (7.9mm) open end wrenches and 1/4" (6.4mm) socket wrench.

To assemble the storage rack, follow these directions:
IMPORTANT: Refer to component terminology page which shows location of parts and parts information page which lists the sizes of braces, shelves and extrusions.

- 1) Attach two casters to each caster bracket using 5/16-18 UNC x 3/4" hex head bolts (M8-1.25 x 19mm), nuts and lock washers.
- 2) Attach side supports to front and rear vertical legs. (See Figure 1.)



Figure 1

- 3) Attach vertical legs/side support assemblies to caster brackets using 1/4-20 UNC x 1/2" hex head bolts (M6-1 x 12mm), nuts and lock washers. (See Figures 2 and 3.)



Figure 2



Figure 3

- 4) Attach rear support to rear vertical legs. (See Figure 4.) The rear vertical legs are inset approximately 4" (100mm) from rear of caster brackets. (See Figure 5.)



Figure 4

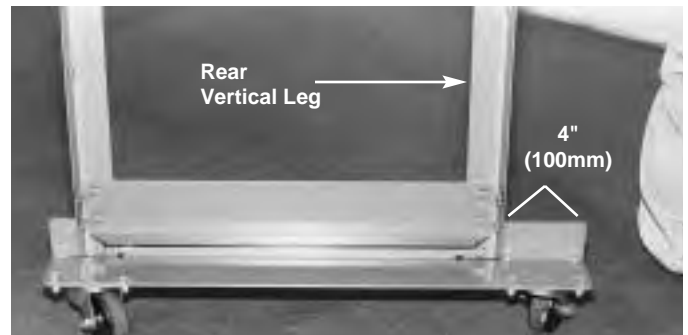

Figure 5

- 5) Attach front support to front vertical legs. (See Figure 6.)
- 6) Lay lower wood shelf in position. (See Figure 7.)



Figure 6



Figure 7

- 7) Assemble two ladder-shaped shelves using the angled supports and crossmembers provided. Figure 8 shows correct way to assemble components. Then attach shelves to vertical legs. (See Figure 9.)

NOTE: Ladder-shaped shelves slope downward toward front of storage rack.



Figure 8



Figure 9

- 8) Attach rear panel to rear vertical legs. (See Figure 10.)



Figure 10

- 9) Attach one of the side panels to the vertical legs. (See Figure 11.)



Figure 11

- 10) Lay upper wood shelf in position. (See Figure 12.)



Figure 12

- 11) Lift end of upper shelf to allow installation of second side panel. (See Figure 13.) Then lower side panel and shelf into position until tabs align and interlock. (See Figure 14.)



Figure 13



Figure 14

- 12) Install front support by sliding it upward at front edge of shelf until tabs align and interlock. (See Figure 15.)



Figure 15

- 13) Secure vertical uprights and leg supports to rear corners of storage rack using 1/4-20 UNC x 3/4" hex head bolts (M6-1 x 19mm), nuts and lock washers. (See Figure 16.)



Figure 16

- 14) Attach lower sign support to vertical uprights. (See Figure 17.)



Figure 17

- 15) Attach two bar clamps and two magnet holders to back of lower sign brace. (See Figures 18 and 19.) Then attach latches to bar clamps using 10-24 UNC x 3/8" round head slotted screws (M5-.08 x 10mm) and nuts. Also attach magnets to holders using magnet clips and 10-24 UNC x 1/2" round head slotted screws (M5-1 x 9mm) and nuts.

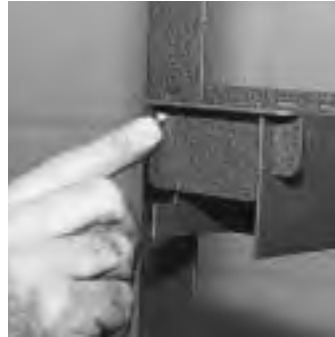

Figure 18



Figure 19

- 16) Attach three scale supports to back of lower rear brace. (See Figure 20.)



Figure 20

- 17) Install sign and upper sign support. (See Figure 21.)



Figure 21

18) Figure 22 shows tool box installed. DO NOT attempt to lift tool box into position without the aid of a helper.

NOTE: Magnets mounted to lower sign brace can be used to hold tool box lid open.



Figure 22

19) Figures 23 and 24 show front and rear view of storage rack with components in place. Figures 25, 26 and 27 show close-ups of bar clamp, scale support and leg support.



Figure 23



Figure 24



Figure 25



Figure 26



Figure 27



PARTS INFORMATION

To order replacement parts for the Universal Measuring System Storage Rack, contact the 24-hour toll-free hotline answering service in Nebraska and leave a message, 1-800-445-9262.

When contacting Chief Automotive Systems, Inc. by telephone or mail, provide the following information: your name, name of your shop, shop telephone number, and shop address. Additional information

needed when ordering: description of part(s), part number(s), and method of payment and shipping charges . . . “Net 30 Days” (with approved credit); or, “Cash With Order” (freight prepaid by Chief Automotive).

NOTE: Chief reserves the right to alter product specifications and/or package components without notice.

(Refer To Illustration On Next Page)

| REF. | PART NO. | QTY. | DESCRIPTION |
|------|----------|------|----------------------------|
| 1 | 315540 | 1 | Caster Bracket (left) |
| 2 | 315541 | 1 | Caster Bracket (right) |
| 3 | 315542 | 2 | Front Support |
| 4 | 315543 | 2 | Side Support |
| 5 | 315544 | 1 | Lower Rear Support |
| 6 | 315545 | 4 | Angled Support |
| 7 | 315546 | 4 | Crossmember |
| 8 | 315547 | 1 | Vertical Upright (left) |
| 9 | 315548 | 1 | Vertical Upright (right) |
| 10 | 315549 | 1 | Rear Vertical Leg (right) |
| 11 | 315550 | 1 | Rear Vertical Leg (left) |
| 12 | 315551 | 1 | Front Vertical Leg (right) |
| 13 | 315552 | 1 | Front Vertical Leg (left) |
| 14 | 315553 | 1 | Rear Panel |
| 15 | 315554 | 2 | Side Panel |
| 16 | 315555 | 1 | Lower Sign Support |
| 17 | 315556 | 1 | Upper Sign Support |
| 18 | 315557 | 3 | Scale Support |
| 19 | 315558 | 2 | Bar Clamp (Upper Clip) |
| 20 | 315559 | 2 | Bar Clamp (Catch) |
| 21 | 315560 | 2 | Magnet Holder (Clip) |
| 22 | 315561 | 2 | Leg Supports |
| 23 | 315562 | 2 | Magnet |
| 24 | 315563 | 4 | Caster |

| REF. | PART NO. | QTY. | DESCRIPTION |
|------|-------------|------|--|
| 25 | 706265 | 4 | Caster Bracket Bolt, 1/4-20 UNC x 1/2 Hex Head |
| 26 | 629247 | 4 | Caster Bracket Nut, 1/4-20 UNC Hex |
| 27 | 629853 | 4 | Caster Bracket Lock Washer, 1/4 Split |
| 28 | 706265 | 4 | Clip Bolt, 1/4-20 UNC x 3/4 Hex Head |
| 29 | 018129 | 4 | Clip Nut, 1/4-20 UNC Hex |
| 30 | 629853 | 4 | Clip Lock Washer, 1/4 Split |
| 31 | 011021 | 2 | Catch Screw, 10-24 UNC x 3/8 Round Head Slotted |
| 32 | 301922 | 2 | Catch Lock Nut, 10-24 UNC Hex Nylon Locking |
| 33 | 301921 | 2 | Magnet Screw, 10-24 UNC x 1/2 Round Head Slotted |
| 34 | 018129 | 2 | Magnet Nut, 10-24 UNC Hex |
| 35 | 010532 | 16 | Caster Bolt, 5/16-18 UNC x 3/4 Hex Head |
| 36 | 018070 | 16 | Caster Nut, 5/16-18 UNC Hex |
| 37 | 707508 | 16 | Caster Lock Washer, 5/16 Split |
| 38 | 092148 | 1 | UMS Sign |
| 39 | 092118 | 2 | Wood Shelf |
| | (not shown) | 1 | Tool Box |
| | (not shown) | 1 | Lid |
| | (not shown) | 2 | Hinge Pin |

UMS STORAGE RACK
(Refer To Parts List On Previous Page)

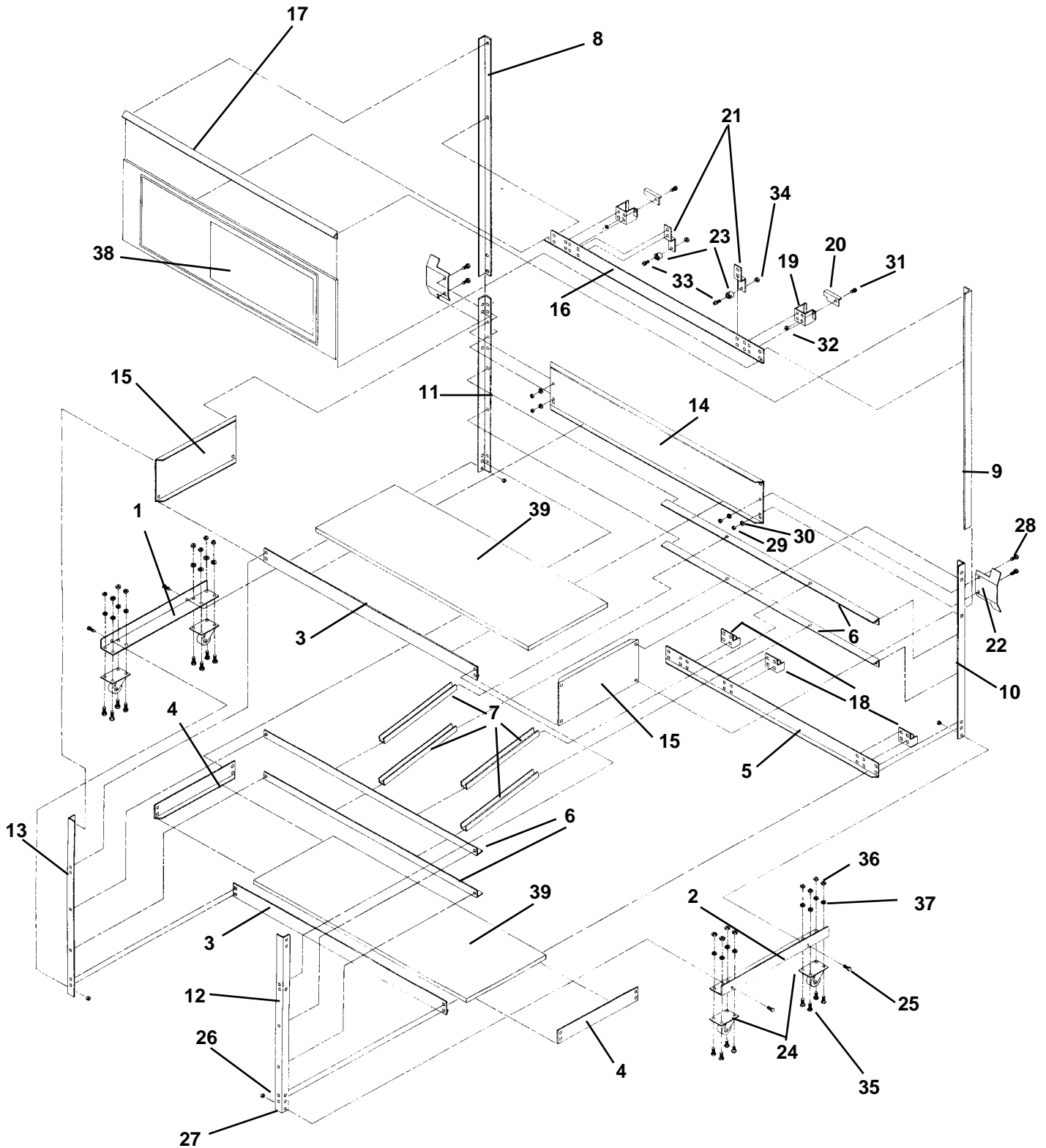



P.O. Box 1368
Grand Island, Nebraska 68802-1368
Phone: 308/384-9747
Fax: 308/384-8966

www.chiefautomotive.com

**Chief reserves the right to alter product specifications
and/or package components without notice.**