

UMS Ladder Extension Installation & Assembly

**OWNERS MANUAL AND
OPERATING PROCEDURES**





CHIEF'S LIMITED ONE-YEAR WARRANTY & LIABILITY

Chief Automotive Technologies, Inc. warrants for one year from date of installation and/or purchase any of its products which do not perform satisfactorily due to defect caused by faulty material or workmanship. Chief's obligation under this warranty is limited to the repair or replacement of products which are defective and which have not been misused, carelessly handled, or defaced by repair or repairs made or attempted by others.

CHIEF AUTOMOTIVE TECHNOLOGIES, INC. DOES NOT ASSUME RESPONSIBILITY FOR ANY DEATH, INJURY OR PROPERTY DAMAGE RESULTING FROM THE OPERATOR'S NEGLIGENCE OR MISUSE OF THIS PRODUCT OR ITS ATTACHMENTS. CHIEF MAKES NO WRITTEN, EXPRESS OR IMPLIED WARRANTY WHATSOEVER OF MERCHANTABILITY OR FITNESS FOR A PARTICULAR PURPOSE OR OTHERWISE REGARDING THE EQUIPMENT OR ANY PART OF THE PRODUCT OTHER THAN THE LIMITED ONE-YEAR WARRANTY STATED ABOVE.

INSTALLATION INSTRUCTIONS

On manufactured systems with Serial Numbers 2522 and back, it will be necessary to return your main ladder for calibration. Contact distributor or sales representative for details. On systems with Serial Numbers 2523 and up, there are two (2) set screw holes on one (1) end of each of the outside rails. Use this end for installation.

Step 1

Slide tape out of tape guide on the main ladder. (See Figure 1.)

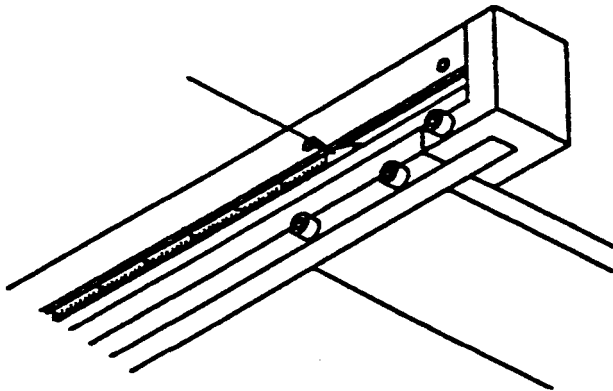

Figure 1

Step 2

Remove tape guide. Check inside of the main ladder on tape guide side for any burrs. If any, remove. This will help tape to slide without interference. (See Figure 2.)

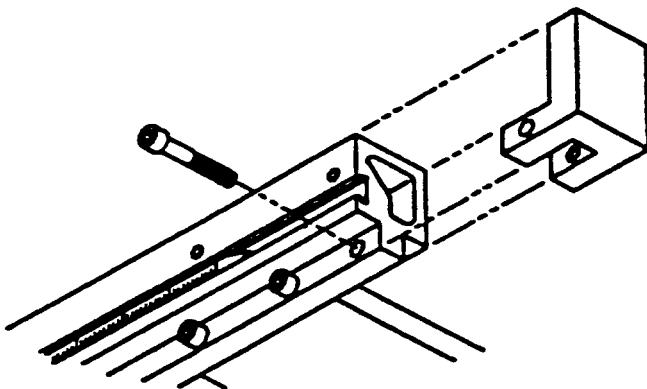

Figure 2

Step 3

Insert connecting bars into ladder extension rails and install the four flat head (connecting bar) screws but do not tighten at this time. (See Figure 3.)

IMPORTANT:

1. Connecting bars are shipped inside of ladder extension rails. They must be removed and their direction reversed prior to reinsertion in ladder extension rails.
2. The connecting bar with cutout for tape goes on tape guide side.
3. Do not loosen ladder extension crossbar screws.

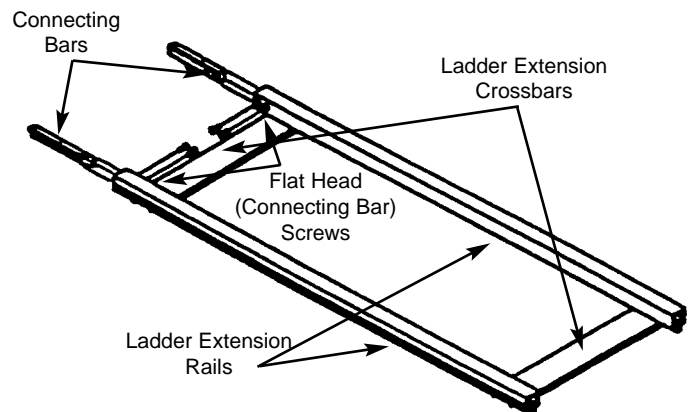

Figure 3

Step 4

Slide the ladder extension into the end of the main ladder. (See Figure 4.)

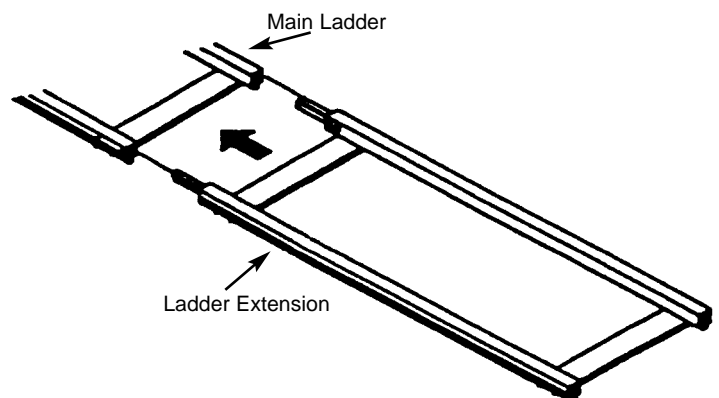

Figure 4

Step 5

Tighten the four flat head (connecting bar) screws on the ladder extension.

Step 6

Install and tighten four (4) set screws on the main ladder. (See Figure 5.)

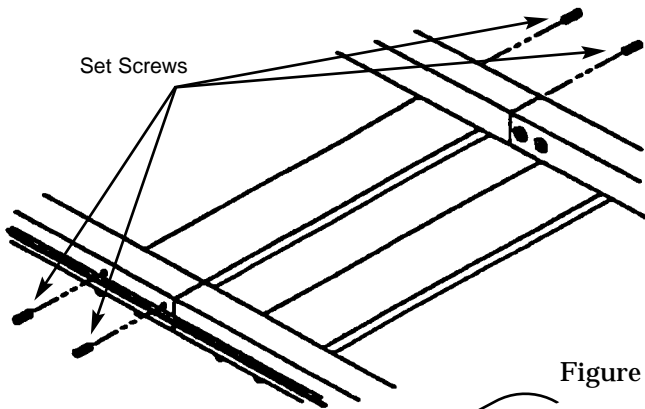

Figure 5

Step 7

Install tape guide on the end of the ladder extension. Slide the tape back into place. (See Figure 6.)

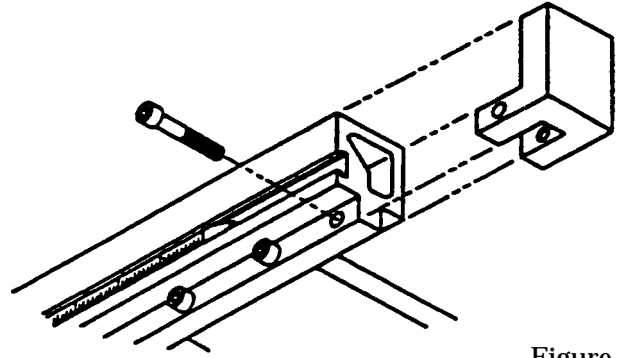
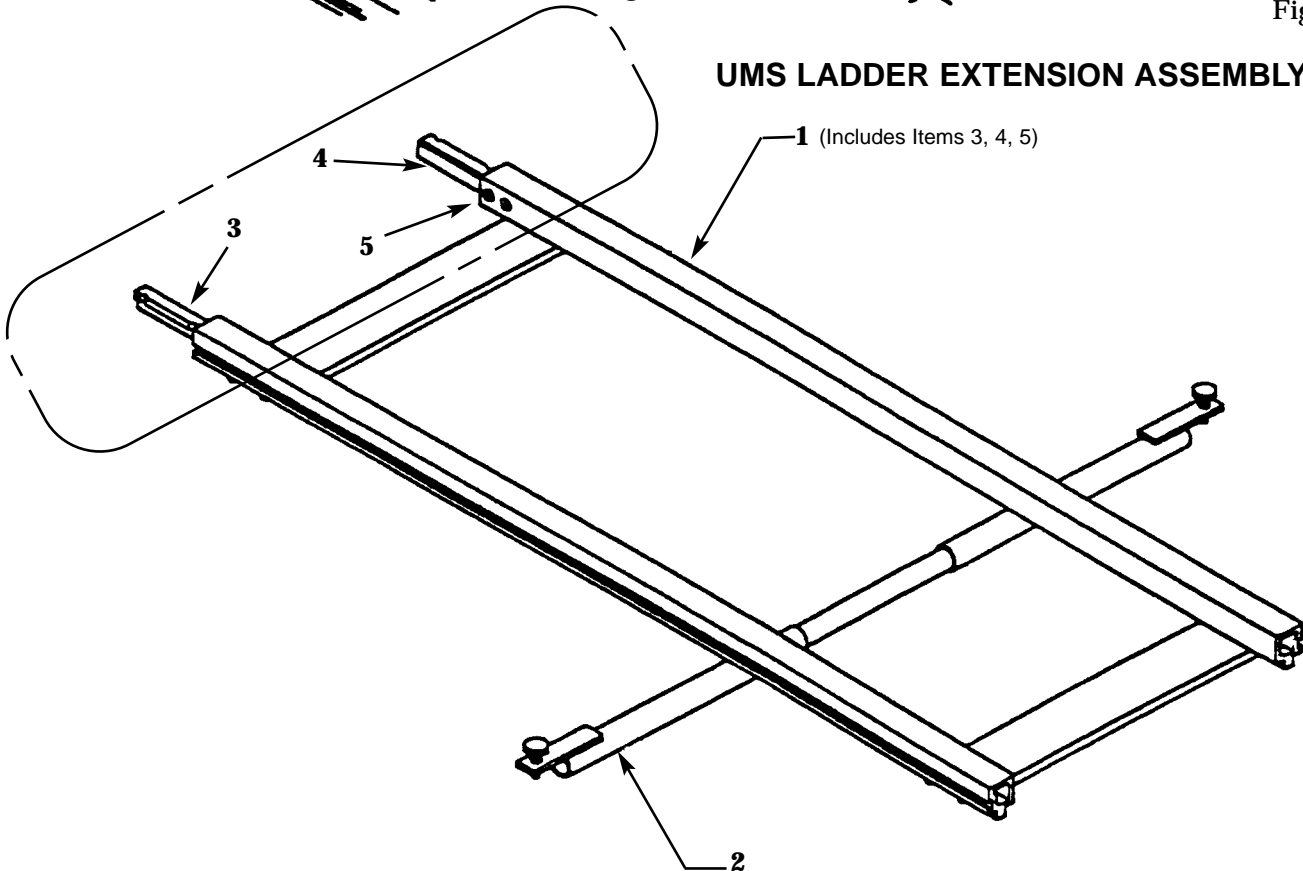

Figure 6

UMS LADDER EXTENSION ASSEMBLY



REF.	PART NO.	DESCRIPTION	QTY.
	319135	4' Ladder Extension Assembly and Support Bar, N/S	1
1	319136	4' Ladder Extension Assembly, N/S	1
2	309880	Adjustable Ladder Support Bar Assembly	1
3	311134	Insert Bar (Rt.)	1
4	311135	Insert Bar (Lt.)	1
5	012134	Flat Head Hex Socket Screw, 1/4-20 x 3/4	4



Box 1368
Grand Island, Nebraska 68802

308-384-9747

**Chief reserves the right to alter product specifications
and/or package components without notice.**