

TITAN-360

USERS MANUAL



CHIEF'S LIMITED ONE-YEAR WARRANTY & LIABILITY

Chief Automotive Technologies warrants for one year from date of installation and/or purchase any component of its Titan-360 Repair System which do not perform satisfactorily due to defect caused by faulty material or workmanship. Chief's obligation under this warranty is limited to the repair or replacement of products which are defective and which have not been misused, carelessly handled, or defaced by repair or repairs made or attempted by others.

CHIEF AUTOMOTIVE TECHNOLOGIES DOES NOT ASSUME RESPONSIBILITY FOR ANY DEATH, INJURY OR PROPERTY DAMAGE RESULTING FROM THE OPERATOR'S NEGLIGENCE OR MISUSE OF THIS PRODUCT OR ITS ATTACHMENTS. CHIEF MAKES NO WRITTEN, EXPRESS OR IMPLIED WARRANTY WHATSOEVER OF MERCHANTABILITY OR FITNESS FOR A PARTICULAR PURPOSE OR OTHERWISE REGARDING THE EQUIPMENT OR ANY PART OF THE PRODUCT OTHER THAN THE LIMITED ONE-YEAR WARRANTY STATED ABOVE.

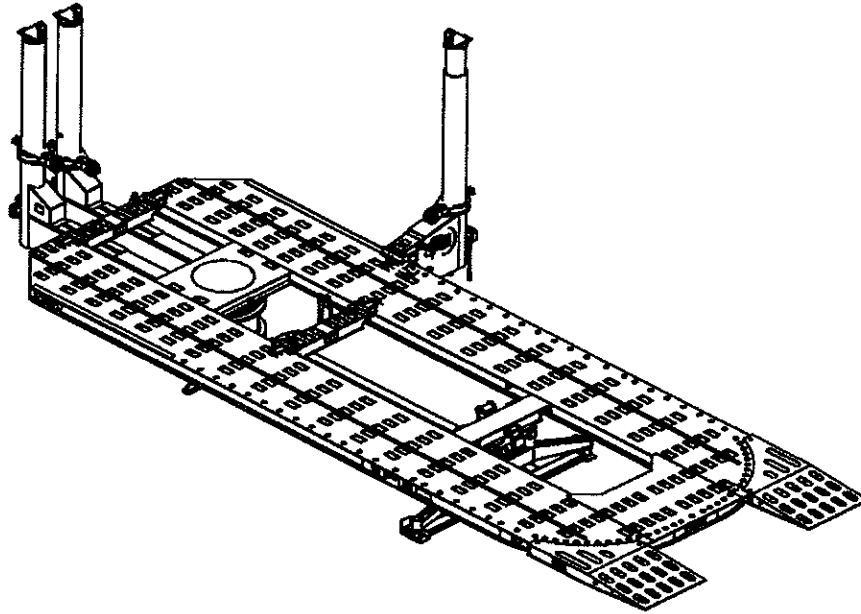

STOP! The Titan-360 machine is shipped without hydraulic oil in the reservoir. Fill the reservoir to within 1" (25 mm) of the fill port using SUS 215 viscosity @ 100°F (38°C) 10W hydraulic oil prior to operating the machine.

This owners manual is written to familiarize operators with the safe and efficient operation of the Chief Titan-360 System. The Titan 360 machine features a unique multiple/simultaneous pulling method to return the vehicle's damaged structure and sheet metal to its original position.

The Titan-360 is available in Series 20 or Series 30 formats. Series 20 systems feature two towers at the front and one or two towers at the rear. Series 30 systems feature three towers at the front and one or two towers at the rear. Both systems tilt hydraulically for either drive on or winch positioning of the vehicle.

Each tower on the Titan-360 features a 10 ton, 10 inch stroke hydraulic cylinder.

NOTE: Illustrations shown in this manual may vary slightly from actual product.

This manual is not intended to replace Chief Automotive Training. For information concerning Training, contact Chief Automotive Technologies

IMPORTANT:

1. DO NOT attempt to operate the Chief Titan-360 without first reading this entire manual.
2. Complete safety information is highlighted throughout this manual and is identified by: 
This safety alert symbol identifies safety information. Operator injury could result if these CAUTION notes are not followed.
3. Qualified service personnel must check operational capacity of the Titan-360 system prior to its initial use and at intervals of no more than one year. Contact Chief Automotive Technologies or contact your authorized Chief Automotive Technologies representative.
4. Persons operating the Titan-360 repair system must be at least 18 years of age, must be trained in the operation of the Titan-360 system, and must have demonstrated their qualifications to the employer. They must also be specifically assigned to operate the Titan-360 system by the employer and this assignment must be made in writing.

IMPORTANT SAFETY INSTRUCTIONS

When using your garage equipment, basic safety precautions should always be followed, including the following:

1. Read all instructions.
2. Care must be taken as burns can occur from touching hot parts.
3. Do not operate equipment with a damaged cord or if the equipment has been dropped or damaged - until it has been examined by a qualified service person.
4. Do not let a cord hang over the ledge of the table, bench, or counter or come in contact with hot manifolds or moving fan blades.
5. If an extension cord is necessary, a cord with a current rating equal to or more than that of the equipment should be used. Cords rated for less current than the equipment may overheat. Care should be taken to arrange the cord so that it will not be tripped over or pulled.
6. Always unplug equipment from electrical outlet when not in use. Never use the cord to pull the plug from the outlet. Grasp plug and pull to disconnect.
7. Let equipment cool completely before putting away. Loop cord loosely around equipment when storing.
8. To reduce the risk of fire, do not operate equipment in the vicinity of open containers of flammable liquids (gasoline).
9. Keep hair, loose clothing, fingers and all parts of the body away from moving parts.
10. To reduce the risk of electric shock, do not use on wet surfaces or expose to rain.
11. Use only as described in this manual. Use only manufacturer's recommended attachments.
12. ALWAYS WEAR SAFETY GLASSES. Everyday eyeglasses only have impact resistant lenses, they are not safety glasses.

SAVE THESE INSTRUCTIONS

HYDRAULIC SYSTEM COMPONENTS

The Chief Titan-360 is powered by an electrically operated hydraulic pump which is operated by a remote control switch. The components of the system are identified in Figures 1a, and 1b. Figure 1a shows a Series 20 system.

Hydraulic pressure is distributed to tower rams, auxiliary rams, and lift ram. The flow of hydraulic fluid to these rams is controlled by a valve. Hydraulic pressure is monitored by pressure gauges mounted on the machine's front towers. To exert hydraulic pressure, press 'up' button on hand-held switch and to release hydraulic pressure, press 'down' button.

NOTE: Although the Titan-360 is a low pressure system, it builds hydraulic pressure quickly. Be aware of this quick reaction when making pulls or lifting vehicle.

IMPORTANT: Tower rams and auxiliary rams can be operated either simultaneously (with equal hydraulic pressure) or individually. The lift ram must be operated individually. Whenever using the hydraulic system, close all valves where hydraulic pressure is not required.

Basic Components

- | | |
|----------------------------|--------------------|
| 1. Pedestal | 11. Tower Ram |
| 2. Removable Loading Ramps | 12. Lift Ram Valve |
| 3. Drain Plug | 13. Lift Ram |
| 4. Control Valve | 14. Pressure Gauge |
| 5. Joy Cord | 15. Emergency Stop |
| 6. Control Switch | 16. Up Button |
| 7. Control Switch Assembly | 17. Down Button |
| 8. Reservoir | |
| 9. Motor | |
| 10. Tower Valve | |

Titan-360 Pump

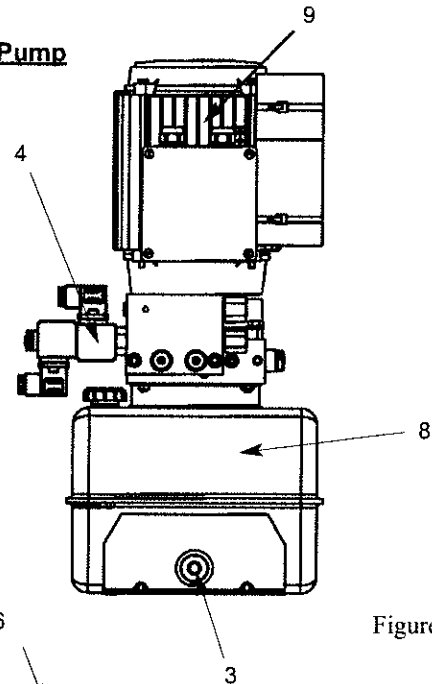

Figure 1b

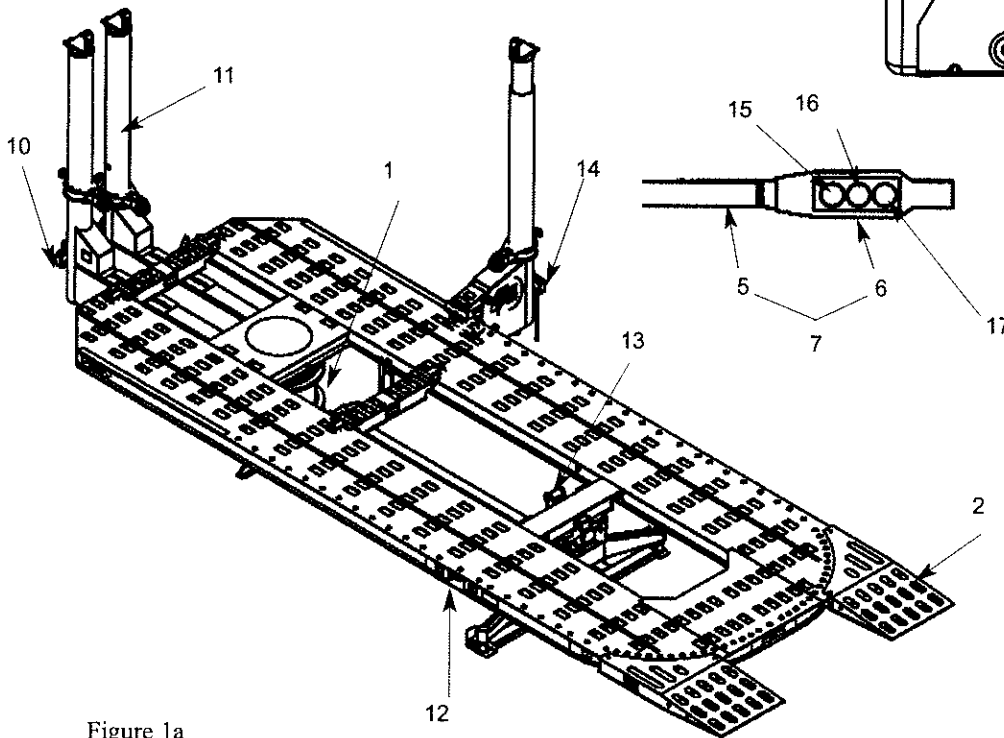

Figure 1a

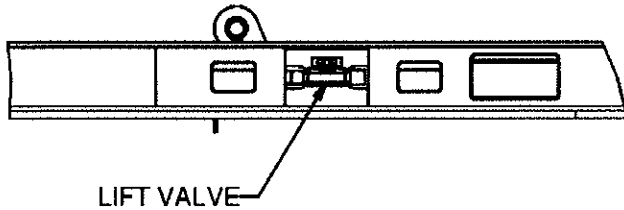

Figure 2

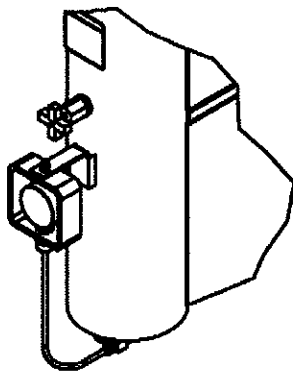

Figure 3



* Titan-360 Auxiliary Ram Line Valve

Figure 4

To operate hydraulic system:

STOP! This machine is shipped without hydraulic oil. Fill the reservoir to within 1" (25 mm) of the fill port using SUS 215 viscosity @ 100°F (38°C) 10W hydraulic oil prior to operating.

1. Open valves to the hydraulic ram(s) to be used. Close valves to all other hydraulic rams. (See Figures 2-4.)

NOTE: To open, turn valve 1/2 turn to left (counter-clockwise). To close, turn valve to right (clockwise). DO NOT overtighten. Over-tightening can damage valve's needle and seat.

IMPORTANT: When using lift valve, observe caution label on lift valve cover.



CAUTION

Do NOT Open This Valve Unless:

1. ALL TOWERS ARE PROPERLY PINNED TO THE MACHINE.
2. VEHICLE'S WHEELS ARE BLOCKED, AND EMERGENCY BRAKE IS SET.

2. Press **up** button on remote control switch to exert hydraulic pressure and press **down** button to release hydraulic pressure. (See Figure 1 — Page 3.)

NOTE: Hold remote control switch so its cord is in a downward position. This positioning reduces stress in this area of the cord.

3. Monitor pressure gauge whenever exerting hydraulic pressure. Titan-360 readings represent tons or kilo Newtons (kN).

NOTE:

- 1) Pressure gauge readings represent amount of pressure each ram applies to its respective chain (and vehicle). Each ram in use exerts the same amount of pressure. The Titan-360 pressure gauge displays pressure readings in tons or kilo Newtons (kN).
- 2) Although the Titan-360 is a low pressure system, it builds hydraulic pressure quickly. Be aware of this quick reaction when making pulls or lifting the vehicle.

IMPORTANT: Monitor pressure gauge continually during repair. Even though the Titan-360 is capable of making strong pulls, most repairs can be made at low pressure by using multiple pulls and proper stress relieving of work hardened metal.

MOVABLE CROSSMEMBERS

The Chief Titan-360 system features two movable crossmembers that mount to the channels on the inner edges of the mainframe. They can be used in front, center or rear sections of machine. Illustration on Page 1 shows normal location of crossmembers.

The primary use of movable crossmembers is to support and secure towers at ends of machine. They can also be used as a base for making hydraulic pulls or pushes when auxiliary rams are positioned perpendicular (90 degrees) with top or bottom of crossmember.

To remove crossmember from machine, hold crossmember secure while turning it counterclockwise. (See Figure 5.) To reinstall crossmember, reverse the procedure making sure it engages the channels on the inner edges of the mainframe.

When movable crossmembers are used in front or rear sections of machine, crossmember locks (see Figure 6) must be used to prevent unintentional movement.

CAUTION:

1. Do not use movable crossmembers as a step.
2. Do not use movable crossmembers as a base to make a hydraulic pull or push unless auxiliary ram is positioned perpendicular (90 degrees) with top or bottom of crossmember.
3. During removal and installation:
 - a. Hold crossmember secure.
 - b. Install crossmember locks to prevent unintentional movement. Crossmember locks are not designed to secure crossmember as a base for hydraulic pulling/pushing.

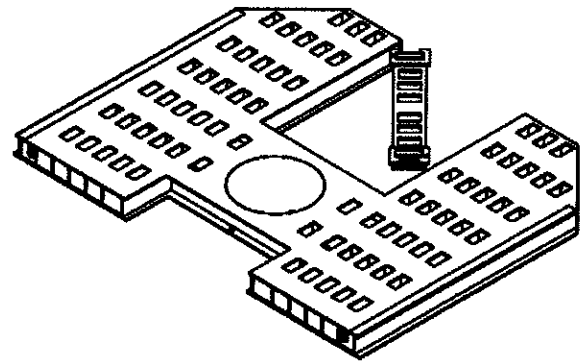
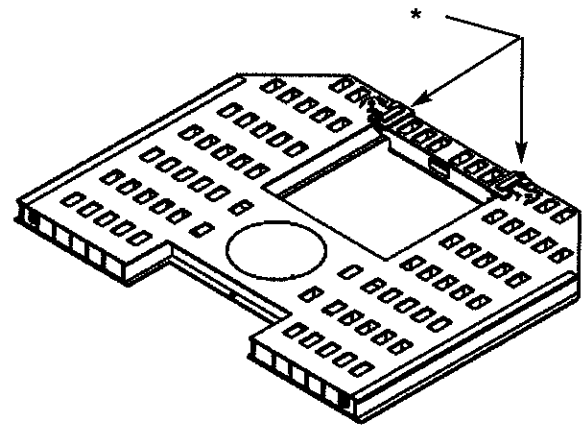
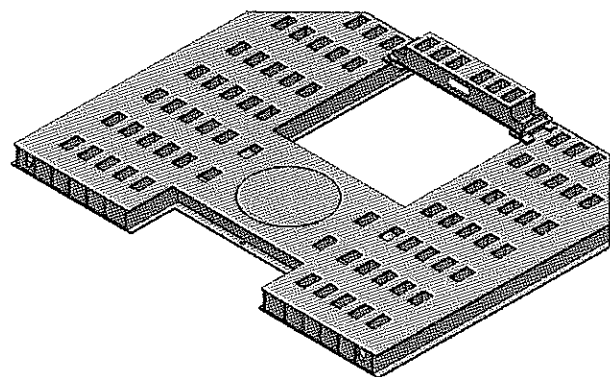

Figure 5



* Movable Crossmember Locks

Figure 6



Inverted Crossmember

FRONT TOWERS

The Chief Titan-360 System is equipped with pulling towers at front of machine. Optional rear towers are also available. Multiple pulls can be set up quickly and are controlled by a hand-held remote control switch. Lateral and elevated pulling angles can be made or changed in just a fraction of a minute.

To operate front towers:

NOTE: Tower operation requires use of tower pins or tower tie bolts. The following procedure references use of tower pins. Tower tie bolt applications appear on Page 8.

1. Swing tower to desired lateral pulling angle and pin it to mainframe or movable crossmember. (See Figure 7.) Tower pin can be used in any tie down hole. (See Figure 8.) DO NOT position tower pin in front of or at rear of movable crossmember as it will apply excessive stress to crossmember locks. Instead, install tower pin through crossmember tie down hole. (See Figure 7.) Tower pin must be fully seated in lower pinning hole to avoid damage to top pinning hole. (See Figure 9.)

CAUTION: Using tower pin along edge of machine can damage the outside track. (See Figure 8)

2. To adjust slack in tower chain, grip chain on each side of tower. (See Figure 10.) Lift out on tail of chain until it is approximately 45 degrees from tower. Then disengage chain from tower head and pull chain to either increase or decrease amount of slack.

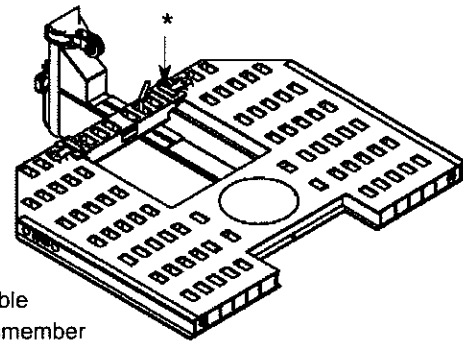

Figure 7

* Movable
Crossmember

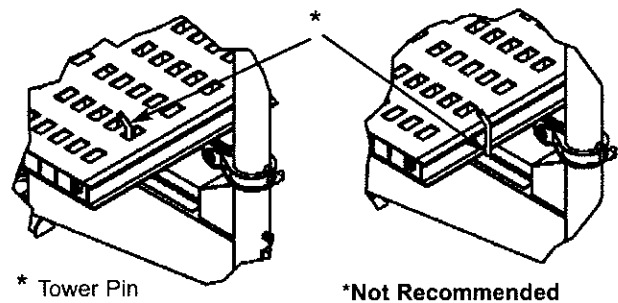
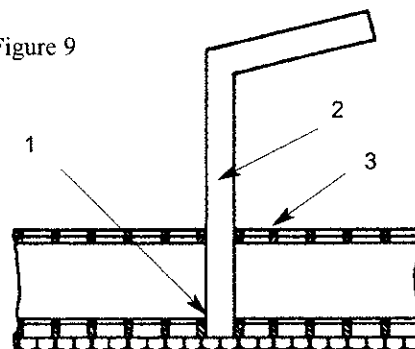

Figure 8

* Tower Pin

*Not Recommended

Figure 9



1 Pin must be seated in this Lower Pinning Hole.

2 Tower Pin

3. Pinning Plate

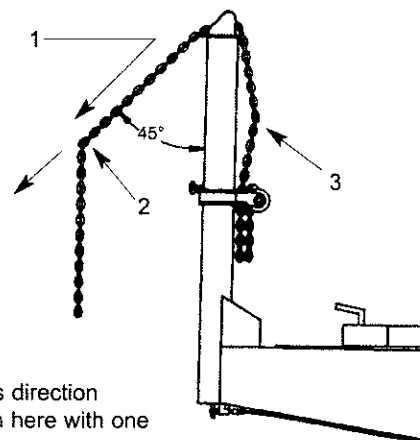

1. Pull in this direction
2. Grip chain here with one hand
3. Grip chain here with opposite hand.

Figure 10

- Support collar with one hand while loosening collar locking knob with opposite hand. Then position collar approximately 3 inches (75 mm) above desired pulling height and retighten collar locking knob. (See Figure 11.)

NOTE: Make sure there is enough slack in chain before loosening collar. After loosening locking knob, it might be necessary to turn collar slightly to disengage it from tower pipe.

- Let tower chain hang free momentarily to remove twist. Then, without twisting chain, attach hook to vehicle. Pull on tail end of chain to remove slack and then lower collar. (See Figure 12.)

IMPORTANT: Remove twist from chain before lowering collar. Make sure that chain links between collar roller and hook align.

- Open tower valve. Then press up button to exert pressure and down button to release pressure.

CAUTION: Observe following WARNING label which appears on tower.

WARNING!

DO NOT position yourself close to, or in line with, chains, clamps, or other accessories while pressure is applied to this system. Failure to observe this warning could result in operator injury due to the possibility of a chain or accessory disengaging or failing while pressure is applied to this system.

IMPORTANT: DO NOT tighten collar locking knob while pressure is applied to system because it will be impossible to loosen the knob without pressure on the system. If it has been tightened by error while pressure is on the system, reapply pressure and loosen the knob.

- When tower is no longer needed, close tower valve, disengage tower chain hook, and store collar using one of the three methods shown in Figure 13.

CAUTION:

- Collar locking knob must be tightened before removing tower chain from vehicle.
- Collar locking knob must be tight when collar is not in use.
- Store collar at bottom of tower pipe or support collar with tower chain.

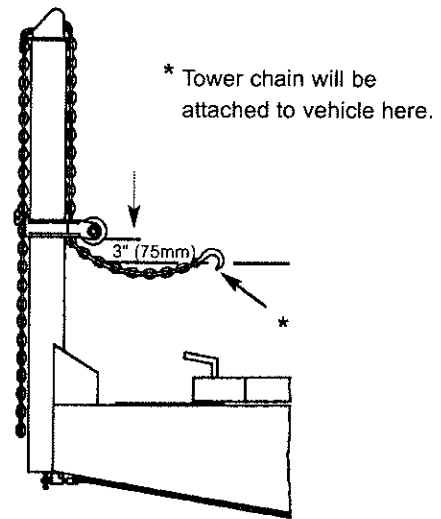

Figure 11

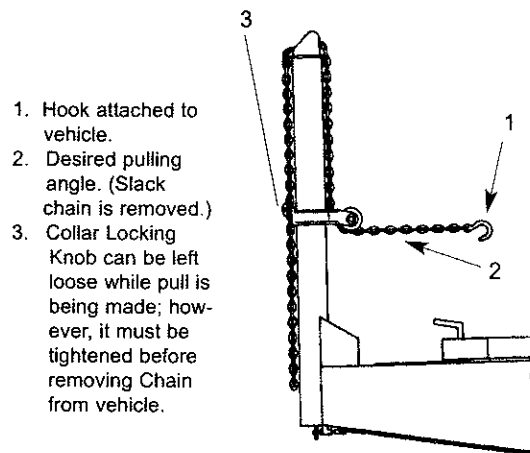

Figure 12

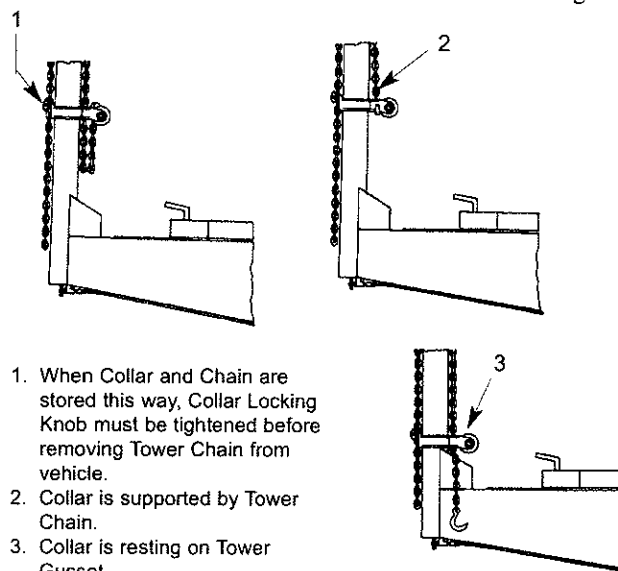

Figure 13

TOWER TIE BOLT APPLICATIONS

Certain pulling and/or pushing situations necessitate use of tower tie bolts in place of tower pins. Tower tie bolts must be inserted through one of the outer tie down holes on mainframe (or movable crossmembers) and be threaded into one of the pinning holes on tower gusset. Tower tie bolts must be tightened to between 120-150 foot pounds (160 -200 Nm) of torque.

Tower tie bolts must be installed when the following situations exist:

1. Tower does not lift up firmly against underside of mainframe when making a pull, for example: when pulling upward at 45 degree angle or less. (See Figure 14.)

NOTE: Tower will not lift in this situation and will be forced down if tower tie bolt is not installed.

2. Auxiliary ram is used to push from tower to vehicle. (See Figure 15.) Tower will be forced down in this situation unless tower tie bolt is installed.

CAUTION: DO NOT attempt this setup without reading Auxiliary Ram Owners Manual.

3. Pull from side of tower exceeds 45 degree angle from tower base. (See Figure 16.) This situation does not necessarily force tower up or down, but instead causes tower pedestal rings to twist.

NOTE: The higher collar is on tower, the more severe the twisting action.

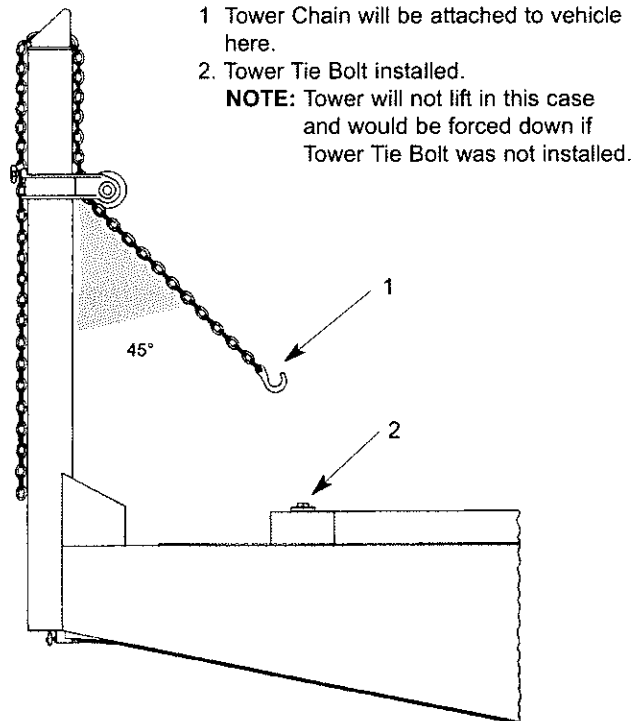
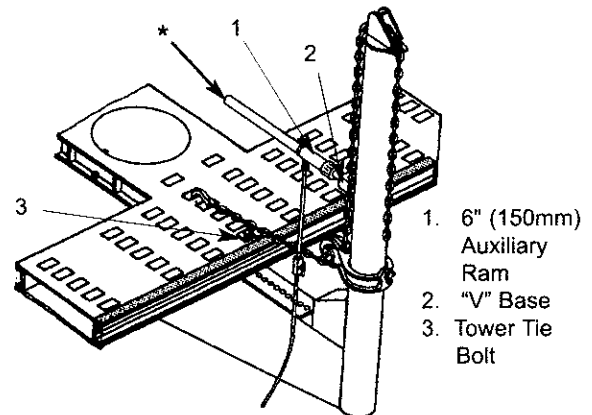

Figure 14



* Use additional attachment here to protect Extension Tubing while pushing on vehicle.

Figure 15

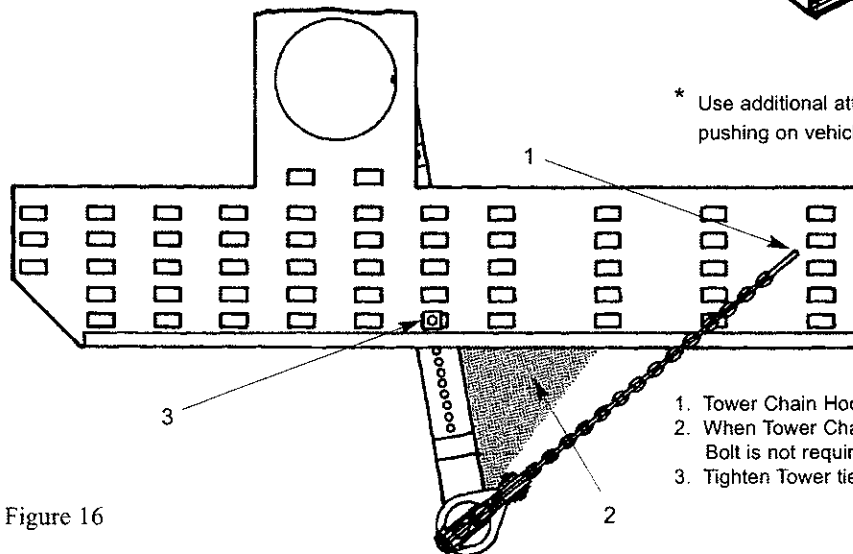

Figure 16

1. Tower Chain Hook is attached to vehicle here.
2. When Tower Chain is used in this area. Tower Tie Bolt is not required. It is required beyond this point.
3. Tighten Tower tie Bolt to specified torque.

REAR TOWERS

The Titan-360 is equipped with one or two roll-around rear towers. The rear towers use “Sure-Lock” force clamps to secure towers to circular pinning holes along the outer edge of the mainframe. The force clamps secure towers to the mainframe while removing stress from the tower assemblies.

To Operate Towers:

1. Step on Sure-Lock release handle to unlock Sure-Lock force clamp from mainframe. (See Figure 17.)
2. Rotate Sure-Lock lock handle forward to fully open Sure-Lock. (See Figure 18.)
3. Push tower to desired location on machine. (See Figure 19.)

CAUTION: When pushing tower, keep one hand on Sure-Lock lock handle and other hand on tower pipe above collar. Also, keep hands away from all pinch points, i .e. roller assemblies on bottom of mainframe plate and force clamp pinning locations on top mainframe plate.

4. To secure tower to mainframe, rotate Sure-Lock lock lever back and down to engage Sure-Lock force clamp with mainframe pinning hole. Fully lock Sure-Lock by stepping on lock lever. (See Figure 20.) Sure-Lock force clamp is fully engaged when outer tower rollers are raised above the outer track.

NOTE: When Sure-Lock is fully engaged, the outrigger spacer should completely contact the bottom surface of the mainframe and the Sure-Lock release handle should have approximately 3/8” of upward movement before contacting lock handle pin.

WARNING: Using 360 tower without Sure-lock correctly engaged can cause personal injury and damage to machine.

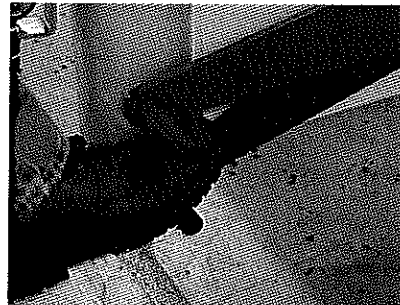

Figure 17

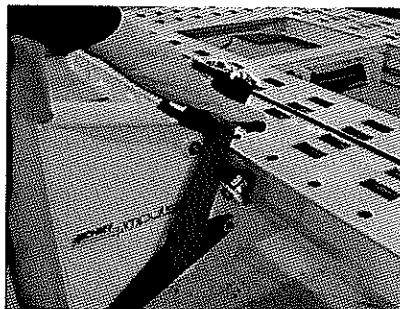

Figure 18

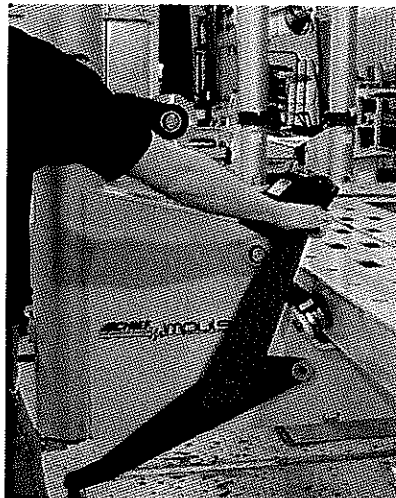

Figure 19



Figure 20

LOWERING/RAISING MACHINE

When lowering or raising a machine with a vehicle aboard observe the following precautions.

⚠ CAUTION:

1. When driving or winching vehicle on or off machine, use helper to guide you. If vehicle's brakes are inoperable, use a Chief Winch and refer to instructions packaged with that accessory.
2. Immediately after positioning vehicle on mainframe, put vehicle in park (if automatic transmission), apply vehicles emergency brake, and have helper block vehicles wheels.
3. Prior to lowering machine, slowly roll vehicle to rear of machine, put vehicle in park (if automatic transmission), apply vehicles emergency brake, and block vehicles wheels. Then install loading ramps at rear of machine.
4. Keep vehicles wheels blocked during raising and lowering procedures and whenever vehicle is not anchored to mainframe.
5. When raising or lowering machine with vehicle aboard, DO NOT walk behind machine.

To Lower Machine

IMPORTANT: Observe preceding precautions when lowering machine with vehicle aboard.

1. Position towers at front of machine and secure them to front movable crossmember using tower pins.
NOTE: Position rear towers as far forward as possible. On machines with two rear towers, pin one to each side.
2. Install loading ramps at rear of machine.
3. Raise lift valve cover and open lift valve half turn to left. Then close all other ram valves.
4. Press 'up' button on remote control switch to lift machine until there is no weight on stiff legs. Then swing stiff legs forward until they are at 30 degree angle from their vertical position. (See Figure 21.)

CAUTION:

1. Clear all obstacles from under and around machine.
2. DO NOT allow anyone or anything to ride on machine or be under machine during lowering procedures.
3. Press 'down' button on remote control switch to lower rear of machine to floor.

NOTE: DO NOT lay remote control switch on machine.

⚠ CAUTION

Do NOT Open This Valve Unless:

1. ALL TOWERS ARE PROPERLY PINNED TO THE MACHINE.
2. VEHICLE'S WHEELS ARE BLOCKED, AND EMERGENCY BRAKE IS SET.

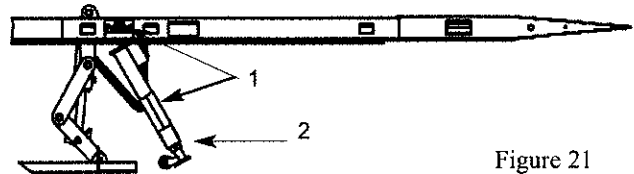

Figure 21

1. Open Lift Valve and raise machine until there is no weight on its Stiff Legs.
2. Swing Stiff Legs rearward until they are at 30 degree angle from their upright position.

To Raise Machine

IMPORTANT: Observe preceding precautions when raising machine with vehicle aboard.

1. Check location of towers making sure they are secured to machine as noted in Step 1 — To Lower Machine.
2. Raise lift valve cover and open lift valve half turn to left. Then close all other ram valves.
3. Press 'up' button on remote control switch to lift machine until stiff legs are in upright position. Then press 'down' button to lower stiff legs into their respective stiff leg catch. (See Figure 22.)

⚠ CAUTION:

1. Clear all obstacles from under and around machine.
2. DO NOT allow anyone or anything to ride on machine or be under machine during raising procedures.
3. Close lift valve and lower lift valve cover.

IMPORTANT: Lift valve must be closed when using any towers or rams.

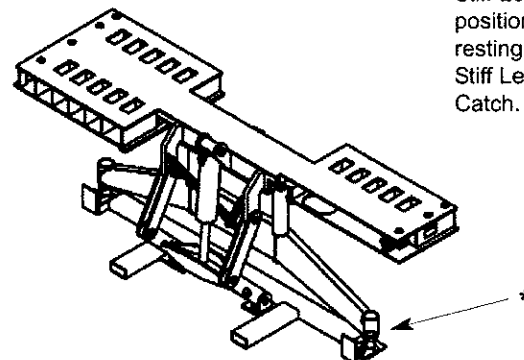

* Stiff Leg is in position and resting within Stiff Leg Catch.

Figure 22

MACHINE MAINTENANCE

Check And Inspect

These components should be checked 'monthly' and anytime a problem is suspected.

Tower Chains, Tie-Down Chains

The tower chains/hooks and tie down chains/hooks supplied with the Chief Titan-360 are high quality, high strength chains/hooks. If replacement is required, purchase only the original Chief product from an authorized Chief Automotive Technologies representative.

CAUTION:

1. DO NOT heat chain or hook while repairing vehicle — 600F (316C) of heat on chain will weaken it.
2. DO NOT tip load chain hook. Tip loading chain hook will stress hook beyond its designed capability and could cause hook to fail.
3. DO NOT pull with twisted chain links. Pulling with twisted chain links will stress chain links beyond their designed capability and could cause chain to fail.

Tower chains must be inspected for wear, nicks, gouges, stretched and bent links. If found, replace chain.

Tower chain hooks must be inspected for twist and stretched openings. If found, replace chain.

Ramps

Inspect ramps for damage. Verify that pins engage holes in deck.

Pedestal Bolts

Remove pump lid and check mainframe to pedestal bolts/ nuts for looseness.

Power and Control Cords

Inspect power and control cords for worn insulation or other damage. If found, replace cord(s).

Tower To Mainframe Gap

Measure gap between top of tower gusset and bottom of mainframe. If gap measures between 3/16 inch (5mm) and 7/16 inch (11mm), see Tower Tie Bolt Usage, Page 8. If gap exceeds 7/16inch (11mm), see Troubleshooting Section — Tower To Mainframe Gap, Page 16.

Cleaning and Lubricating

These components should be cleaned and lubricated as specified for trouble free and extended service. When lubricating use the following:

Oil — Use 30 weight motor oil for all components requiring oil.

Grease — Use a SUS750 Lithium type grease such as lubricate #630-2 for all components requiring grease.

Tower Heads

Grease tower heads every six months.

1. Remove tower chain from tower head.
2. Remove tower head from tower pipe.
3. Clean dirt from tower head pipe and where tower head pipe rubs on inside of tower pipe.
4. Apply grease to tower head pipe and inside of tower pipe.
5. Reinstall tower head and tower chain.

Collars

1. Clean and lubricate collars monthly.
2. Use compressed air to blow out dirt or dust that collects between collar ears and rollers.
3. Place a few drops of oil on roller pin between roller and collar ears (each side). Then turn roller a few times. Roller must turn freely.

Front Tower Pinning Holes

1. Use compressed air to blow dirt or dust from front tower pinning holes. Remove any debris that collects in holes.



Caution: Wear safety glasses while using compressed air to blow out dirt and dust.

Lift Cylinder

Grease lift cylinder every six months.

Stiff Leg Assembly

Oil stiff leg assembly pivot points and rollers every two months.

1. Clean dirt from pivot points.
2. Place a few drops of oil at each pivot point and on roller pins.

Tower Rings

1. Grease tower rings every six months. Dirt and plastic dust can accumulate on rings and pedestal ring grooves causing towers to turn hard. Developing a bead of grease between rings and pedestal ring grooves seals out much of the dirt and plastic dust.
2. Wipe old grease and dirt from rings and pedestal ring grooves.
3. Swing towers to one side of machine and position against mainframe.
4. Use grease gun to apply grease to each grease fitting (2 per ring) on rear half of each ring. Apply enough grease so a small bead of grease develops between ring and pedestal ring groove.
5. Swing towers to opposite side of machine and position against mainframe. Then repeat Step 3.
6. Swing towers several times to work grease around rings and pedestal ring grooves. If more grease is needed, repeat the procedure.

NOTE: If tower still swings hard, see Troubleshooting Section — Towers Swing Hard, Page 16; or, see following segment on Cleaning Pedestal Ring Grooves.

Cleaning Pedestal Ring Grooves

If preceding procedures will not correct tower(s) that swing hard, thoroughly clean pedestal ring grooves.

1. Swing towers to one side of machine and bolt towers to mainframe using tower tie bolts.

 **CAUTION:** Failure to properly bolt towers to mainframe could result in operator injury as well as damage machine.

2. Remove upper and lower rear halves of tower ring.

IMPORTANT: Mark each ring's location before removing and note number and location of shims that are between front and rear halves of rings. Rings and shims must be reinstalled in their original locations.

3. Wipe dirt and grease from rings and pedestal ring grooves. Then wipe ring grooves with a solvent soaked rag and wipe dry.
4. Apply grease to pedestal ring grooves.
5. Replace upper rear halves of rings and secure bolts — snug only.
6. Remove tower tie bolts, swing towers to opposite side of machine and reinstall tower tie bolts securing towers to mainframe.

 **CAUTION:** Failure to properly bolt towers to mainframe could result in operator injury as well as damage to machine.

7. Remove upper rear halves of rings and repeat Step 3 on this side of machine.
8. Apply grease to pedestal ring grooves and to rear halves of rings.
9. Replace upper and lower rear halves of tower rings and tighten ring bolts.

IMPORTANT: Rings and shims must be reinstalled in their original position.

10. Apply a small bead of grease between rings and pedestal ring grooves to keep much of the dirt and plastic dust out of the ring area. See preceding information on Tower Rings.

Eliminating Air In Hydraulic System

All air has been removed from hydraulic system at the factory, but if hydraulic system is opened to replace a system component, it is necessary to bleed air from system prior to using it. Contact a Chief Automotive Representative.

Sure-Lock

With normal use, the pivots on the Sure-Lock clamping system should stay free of dirt and operate smoothly and quietly. Extended periods of non-use or damp environments may adversely affect the operation of the Sure-Lock.

Use compressed air to blow dirt and debris from Sure-Lock pivot points. Apply a few drops of oil to Sure-Lock pivot pin and handle shaft pivots and work mechanism.

Note: It may be necessary to remove the handle shaft retainer bolt and washer to lubricate both sides of the handle shaft. Refer to parts manual exploded view for details on removal of handle shaft retainer components.

Caution: Wear safety glasses while using compressed air to blow out dirt and dust.

The rotational motion of the Sure-Lock handles is transmitted to the Sure-Lock linkage via a 1/4" key. The key is retained by a 1/4-20 bolt. Verify that the bolt is tightened correctly.

Visually inspect the internal Sure-Lock linkage to verify that the Tower Linkage Driver bar is centered on the Sure-Lock handle shaft. With the Sure-Lock clamp in the locked position, verify that both float linkage bars engage the handle shaft.

360-10 Ton Tower

Using compressed air, blow dirt and debris from the tower outside wheel assemblies. Visually inspect the bolts retaining the outside wheels to the tower weldment and the outside roller guard for damage.

Verify that the four bolts retaining the tower hook to the inside end of the 360 tower are not loose. Verify that the two bolts holding the tower outrigger block are tight.

Note: Refer to Parts Manual for detailed exploded views of referenced parts. Contact Chief Automotive Technologies with any questions regarding the usage or maintenance of the Titan-360 system.

Outer Track

Using compressed air, blow dirt and debris from outer track. If necessary, use stiff brush to remove build-up of dust and paint on outer track surface.

Visually inspect outer track for damage. Although small dents or upsets in the outer track may not affect the operation of the tower, they might indicate tower adjustment is necessary.

Hydraulic Pump Removal

1. Disconnect power supply cord from power supply and pull cord out through top of pedestal opening.
2. Coil remote control switch cord and position it on top of motor. Or disconnect remote control switch at mini change receptacle (if equipped) and pull it out through bottom of pedestal.
3. Lift pump out of pedestal.

Note: If bolts securing pump to base of pedestal have not previously been removed, remove them. The bolts are only necessary for transporting the Titan-360.

Hydraulic Pump Installation

1. Set pump in pedestal.

Note: It may be necessary to pull up slightly on hoses that attach pump to hose block to prevent it from being pinched under pump.

2. If remote control switch cord is coiled and positioned on top of motor, route hand-held control unit out through bottom of pedestal. If remote control switch cord is disconnected, re-route cord through bottom of pedestal and reconnect at mini-change receptacle.
3. Insert power supply cord at top of pedestal. Route it through bottom of pedestal and reconnect it to power supply.

Troubleshooting

Problem	Possible Cause	Possible Solution
Pump will not run	Power cord disconnected	Plug in power cord
	Power cord damaged	Inspect power cord for damage - Contact Chief Automotive service representative for repair if necessary
	Circuit breaker tripped or blown fuse	Reset circuit breaker or replace fuse
	Damaged pendant cord	Inspect pendant cord for damage - Contact Chief Automotive for repair or replacement if necessary
	Blown control circuit fuse Bad pendant	Remove and inspect fuse. Replace if necessary Replace Pendant. Contact Chief Automotive service representative
	Bad motor start relay	Replace motor start relay - Contact Chief Automotive service representative
Pump will not build pressure or builds pressure slowly	Hydraulic fluid low	Fill fluid reservoir to within 1.5 to 2" (38mm to 50mm) of top with SUS215 viscosity @ 100° F (38C) 10W hydraulic oil with all cylinders down and machine sitting level
	Sticking PO check valve	Cycle machine up and down several times to flush valve
	Contamination in startup valve	Remove and clean startup valve - Contact Chief Automotive service representative
	Directional valve not shifting	Replace directional valve - Contact Chief Automotive service representative
Pump will not hold pressure	Hydraulic fluid leak	Check hoses, fittings and quick couplers for leaks. Tighten or replace if necessary
	Tower, auxiliary or lift valve open	Close all tower, auxiliary and lift lines
	Leaking PO check valves	Cycle machine up and down several times to flush valve
	Leaking tower, auxiliary or lift valve	Replace leaking valve - Contact Chief Automotive service representative
	Leaking ram	Replace ram - Contact Chief Automotive service Representative
Pump stalls or will not start under pressure	Facility wiring inadequate	Rewire facility to comply with local electrical code. Add dedicated line with 30 amp breaker
	Extension cord too long or wire gauge too small	Use extension cord rated for 25 amps at 120 volts with ground wire up to 25 feet (7.5m) long IMPORTANT: Extension cord use is not recommended. If used, extension cords must meet standards (listed above) and be used only on a short term basis
Front tower will not raise	Tower valve closed	Open tower valve one turn
	Lift valve open	Close lift valve
	Rear tower or auxiliary line valve open	Close rear tower and auxiliary line valves
	Directional valve "UP" coil not working	Check inside coil (V1) for magnetic field - Contact Chief Automotive service representative
	Directional valve sticking	Clean or replace Directional valve - Contact Chief Automotive service representative
	PO check valve sticking	Cycle pump up and down several times to flush valve
	Startup valve sticking	Remove and clean startup valve - Contact Chief Automotive service representative

Troubleshooting

Problem	Possible Cause	Possible Solution
Rear tower will not raise	Auxiliary line valve closed	Open auxiliary line valve one turn
	<i>Quick coupler not tight</i>	<i>Tighten quick coupler</i>
	Front tower valve open	Close all unused tower valves
	<i>Lift valve open</i>	<i>Close lift valve</i>
	Auxiliary line connection reversed	Verify that black marked coupler on auxiliary line is attached to correct coupler on rear cylinder
	<i>PO check valve sticking</i>	<i>Cycle pump up and down several times to flush valve</i>
	Start-up valve sticking	Remove and inspect start-up valve - Contact Chief Automotive service representative
	<i>Directional valve sticking</i>	<i>Remove and inspect directional valve - Contact Chief Automotive service representative</i>
Front tower will not retract	Directional valve "UP" coil not working	Replace coil - Contact Chief Automotive service representative
	Tower valve closed	Open tower valve one turn
	<i>Rear tower or auxiliary line valve open</i>	<i>Close rear tower and auxiliary line valves</i>
	PO check valve sticking	Cycle pump up and down several times to flush valve
	<i>Start-up valve sticking</i>	<i>Replace start-up valve - contact Chief Automotive service representative</i>
	Directional valve sticking	Remove and inspect directional valve - Contact Chief Automotive service representative
	<i>Directional valve "DOWN" coil not working</i>	<i>Replace coil - Contact Chief Automotive service representative</i>
Rear tower will not retract	Auxiliary line valve closed	Open auxiliary line valve one turn
	<i>Quick couplers not tight</i>	<i>Tighten quick couplers</i>
	Front tower valve open	Close all unused tower valves
	<i>Auxiliary line connections reversed</i>	<i>Verify that black marked coupler on auxiliary line is attached to correct coupler on rear cylinder</i>
	PO check valve sticking	Cycle pump up and down several times to flush valve
	<i>Start-up valve sticking</i>	<i>Remove and inspect start-up valve - Contact Chief Automotive service representative</i>
	Directional valve sticking	Remove and inspect directional valve - Contact Chief Automotive service representative
	<i>Directional valve "DOWN" coil not working</i>	<i>Replace coil - Contact Chief Automotive service representative</i>
Hydraulic oil leakage	Hose leaking	Replace hose
	<i>Loose quick coupler</i>	<i>Tighten quick coupler</i>
	Loose fitting	Tighten fitting
	<i>Inadequate sealant on pipe threads</i>	<i>Apply Teflon tape to pipe threads after properly cleaning and retighten fitting</i>
	Overfilled pump reservoir	Drain to 2" (50mm) below fill cap
Machine will not lift	Lift valve not open	Open lift valve one turn
	<i>Tower or auxiliary valve open</i>	<i>Close all tower and auxiliary valves</i>
	Too much weight at rear of machine	Move vehicle forward on machine
	<i>Vehicle weight exceeds lift capacity</i>	<i>Do not attempt to load vehicle</i>
	Inadequate hydraulic pressure	Verify 10 tons of pressure on tower gauge
	<i>Object under pedestal</i>	<i>Lower machine and remove object</i>

Troubleshooting

Problem	Possible Cause	Possible Solution
Machine will not lower	Lift valve not open	Open lift valve one turn
	Stiff leg supporting machine	Raise machine and pivot stiff leg rearward. Lower machine while holding stiff leg in position until stiff leg rollers contact floor
Front towers swing hard	Ring grooves dirty	Clean and degrease. See machine maintenance, page 9
	Bent tower rings	Repair or replace - Contact Chief Automotive service representative
	Crushed tower ring bearings	Replace bearings - Contact Chief Automotive service representative
Front towers jump when swung	Pedestal is dented	Repair or replace pedestal - Contact Chief Automotive service representative
Front tower to mainframe gap exceeds 7/16 inch (11mm)	Improper use	Readjust tower. Straighten tower ring - Contact Chief Automotive service representative
Rear towers roll hard	Dirt on outer track	Clean outer track
	Dirt in outer tower roller bearings	Clean outer tower roller bearings
	Tower shimmed incorrectly	Re-shim tower - Contact Chief Automotive service representative
	Damaged inner roller	Replace inner roller - Contact Chief Automotive service representative
	Damaged track	Repair track - Contact Chief Automotive service representative
Sure-Lock difficult to engage	Dirt on deck	clean deck
	Dirt in Sure-Lock pivots	Clean Sure-Lock pivots. Apply a few drops of oil to pivots and operate Sure-Lock mechanism
	Sure-Lock out of adjustment	Re-shim Sure-Lock - Contact Chief Automotive service representative
Sure-Lock difficult to disengage	Dirt in Sure-Lock pivots	Clean Sure-Lock pivots. Apply a few drops of oil to pivots and operate Sure-Lock mechanism
	Sure-Lock out of adjustment	Re-shim Sure-Lock - Contact Chief Automotive service Representative
Collars jump under load	Improper fit between collar and tower pipe	Refit collar - Contact Chief Automotive service representative

Chief Titan-360 Specifications
(Series 30 / Series 20 Models)

Weight (31 Series).....	7,250 lbs. (3,262 kg)
Weight (32 Series).....	7,900 lbs. (3,555 kg)
Weight (21 Series).....	5,800 lbs. (2,610 kg)
Weight (22 Series).....	7,100 lbs. (3,195 kg)
Power Required.....	120v, 20 amp, 60 hz. 220v, 10 amp, 50 hz
Hydraulic Power.....	10 tons per tower (89 kN)
Hydraulic Fluid.....	9.5L SUS215 Viscosity, 100° F (38C), 10W
Controls.....	One hand-held unit on 25' (7.6m) of cord
Length.....	21' 8" (6.6m) (safety ramps included) 23' 1" (7m) maximum length with front towers extended 24' 3" (7.39m) with front and rear towers extended
Width.....	7' 4" (2.23m) 12' 10" (3.9m) with front towers extend- ed to both sides 14' 4" (4.4m) with front and rear towers extended to both sides
Height.....	8' 5" (2.56m) 9' 3" (2.82m) with tower rams extended up
Clearance.....	2' (.6m) recommended on all sides
Working Height.....	31" (.79m) from floor to top of mainframe
Tie Down Openings.....	250
Lift Capacity.....	12,000 lbs. (2,950 kg)
Sound Pressure Level at Control Position.....	81 dB(A)



996 Industrial Drive
Madison, IN 47250
Phone: 800-445-9262
Fax: 866-275-0173

www.chiefautomotive.com

**Chief reserves the right to alter product specifications
and/or package components without notice.**