

S21M Users Manual Insert

S21M 17' Model

USERS MANUAL INSERT



S21M 17 Foot Model

The "17 foot" version of the S21M Pulling System is much like the S21M "20 foot" model. For most operational procedures, technicians should refer to the S21M Users Manual (Part No. 601198).

The primary differences regarding the "17 Foot" Model relate to machine specifications, the absence of auxiliary rear towers, and the design of the lift system.

In regard to **machine specifications** (see Figure 1), the S21M "17 Foot" Model weighs 400 lbs. less than than the S21M "20 Foot" Machine. It is also 2' 10" shorter from front to rear. The shortened length also means a slight reduction in tie down openings from 250 to 224 and a slightly steeper loading / unloading angle. All other specifications are the same including power requirements, width dimensions, height dimensions, lifting capacity and sound pressure level at the control position.

The shortened mainframe of the S21M "17 Foot" Machine **will not accomodate the installation of Auxiliary Towers**. As an alternative, however, technicians may use a Portable Tower System (see Figure 2) that will allow them to make pulls at both the sides of the machine and the rear of the machine.

Portable Towers attach to pedestals that can be moved for

ward or rearward along the inner channels of the mainframe. The tower(s) operates from the EZ Liner control switch individually or simultaneously with existing towers and auxiliary rams. (See ordering information - next page.)

Pedestals can be used in either the center or rear sections of the machine. Once installed they are held in place by pedestal locks that mate with tie down holes on the inside edges of the treadway. (See Figure 2 Inset.) Portable Towers attach to housings on the underside of the pedestal and are secured to the machine using tower pins.

The **lift mechanism** for the S21M "17 Foot" Model (see Figure 3) has been modified to allow the shortened mainframe to reach the floor when lowered. The design change required the installation of a larger lift ram featuring a 3 1/2 inch bore and 7 5/8 inch stroke.

The design changes have been beneficial in two ways. Lift components no longer protrude above the top surface of the mainframe, and the lifting forces no longer stress the deck but are confined within the restructured lift mechanism.

NOTE: Refer to this insert when ordering Lift System parts for the S21M "17 Foot" Machine. For other parts refer to the S21M Parts Manual (Part No. 601199).

S21M "17 Foot" Specifications

Weight.....	6,600 lbs. 3,000 k.g.)
Power Required.....	120v, 15 amp, 60 hz.
Hydraulic Power.....	10 tons per tower (89kN)
Hydraulic Fluid.....	9.5L SUS215 Viscosity, 100degrees F (38 degrees C), 10W
Controls.....	One hand-held unit on 21' (6.4m) of cord
Length.....	18' 10" (5.74m) - loading ramps included 20'3" (6.17m) - maximum length with front towers extended
Width.....	7'4" (2.24m) 12'10" (3.9m) with front towers extended to both sides
Height.....	8'5" (2.56m) 9'3" (2.82m) with tower rams extended up
Clearance	2' (.6m) recommended on all sides
Working Height.....	31" (.79m) from floor to top of mainframe
Tie Down Openings.....	224
Lift Capacity.....	6,500 lbs. (2,950 k.g.)
Sound Pressure Level	
At Control Position.....	.91 dB(A)

Figure 1

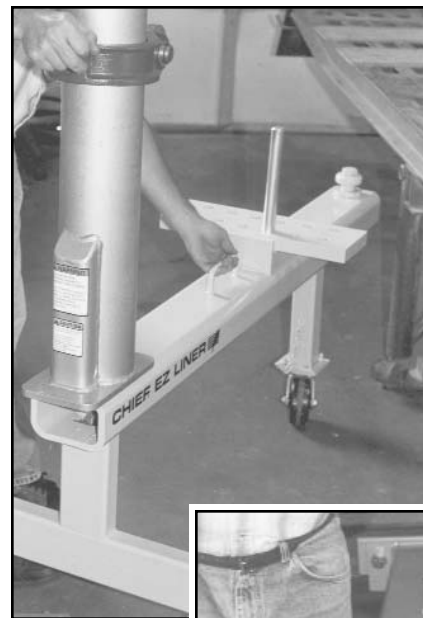
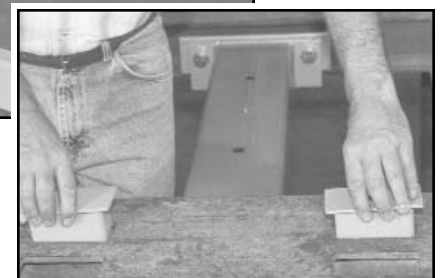

Figure 2



S21M "17 Foot" Lift System

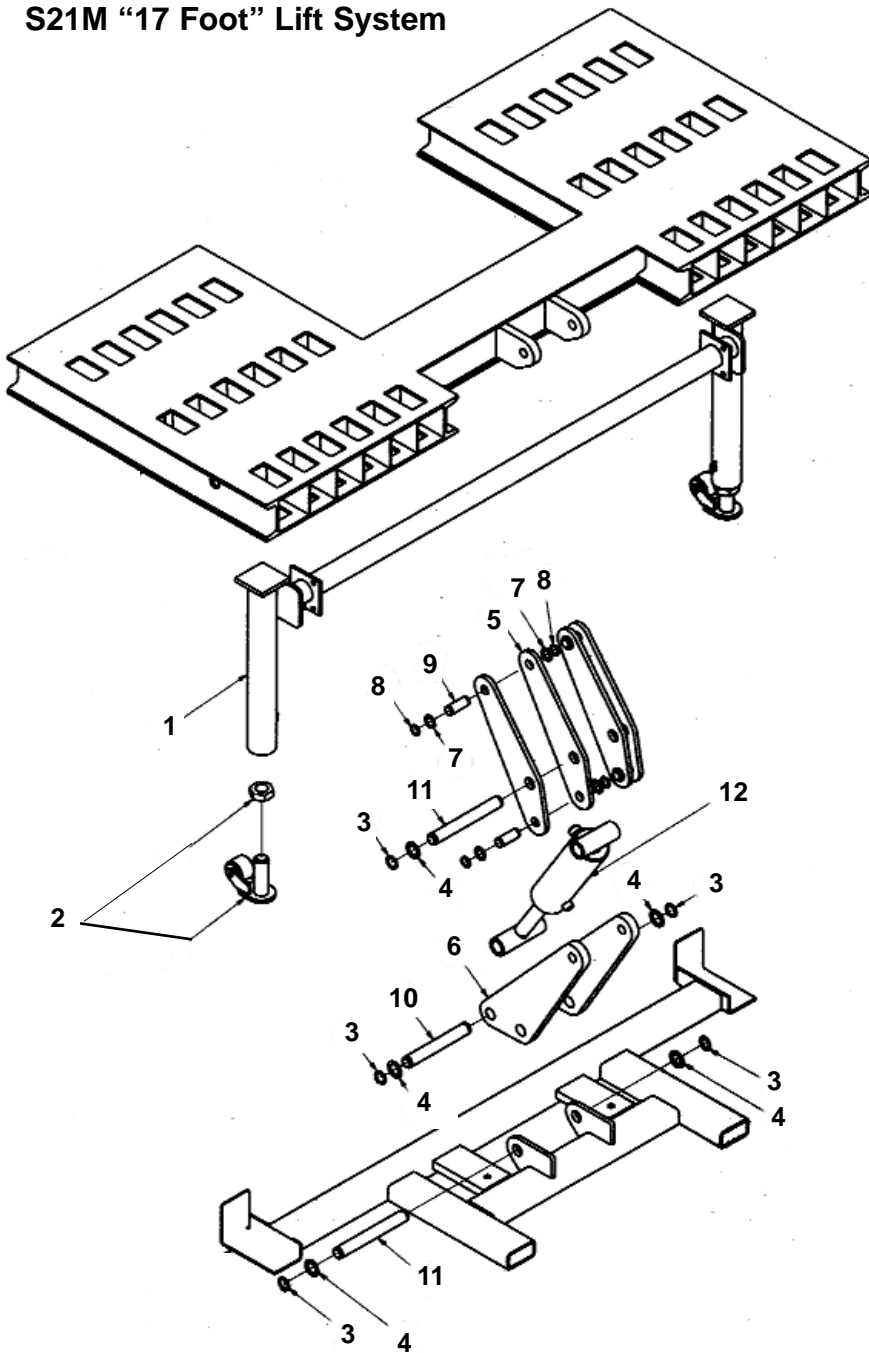

Figure 3

PARTS INFORMATION

To order a new Portable Tower System or to order replacement parts for the S21M ("17 Foot" Model) Lift System, contact Chief Automotive Systems, Inc. 800-445-9262. If outside the United States, contact nearest Chief Automotive Systems, Inc. representative.

When ordering by telephone or mail, provide the following information: name, name of business, business telephone number, business address, description of part(s) and part number(s).

Ref	Part No.	Description
		Portable Tower System
	600514	Single Rear Tower and Pedestal* for S21M 17'
	600515	Dual Rear Tower and Pedestal* for S21M 17'

* Pedestal must be installed by authorized Chief Automotive Service Representative.

Ref	Part No.	Description
		S21M Lift System, 17'
1	672253	Weldment, S21 Stiff Leg
2	610677	Stiff Leg Adjustment Screw Assembly
3	693468	Snap Ring, HD For 1 1/4" Shaft
4	707487	Washer, Flat - 1 1/4" ID x 1 7/8" OD x 14 Ga - Pl.
5	603216	Top Lift Arm, S21M/17'
6	603206	Bottom Lift Arm, S21M/17'
7	707479	Washer, 1" Thrust Plated
8	770105	HD Retaining Ring
9	770155	Pin, 17' Cylinder Retainer
10	603152	Pin, Grooved, 1.25 DIA. x 9" Long
11	603151	Pin, Grooved, 1.25" DIA. x 10" Long
12	601202	Ram, Lift, 3 1/2" bore x 7 5/8" stroke



**P.O. Box 1368
Grand Island, Nebraska 68802-1368
Phone 308-384-9747
Fax 308-384-8966**

**CHIEF AIRCO EUROPE
CA de TREMBLAY CHARLES DE GAULLE
18, rue Henri FARMAN
93297 TREMBLAY EN FRANCE CEDEX
TEL 01 41 51 16 80
FAX 01 48 60 09 88**

www.chiefautomotive.com

**Chief reserves the right to alter product specifications
and/or package components without notice.**