

# S21M Auxiliary Rams

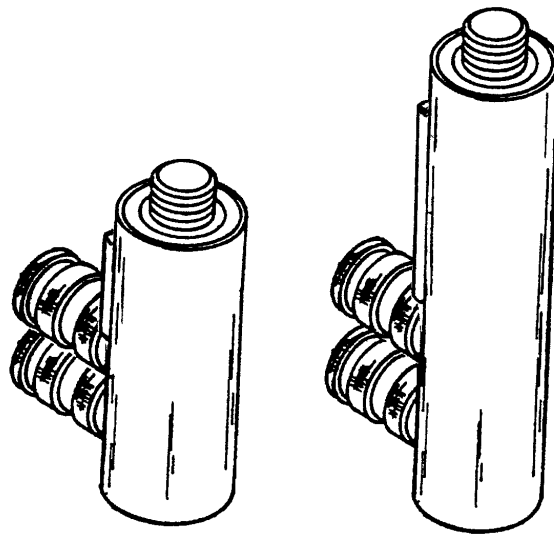

**USERS MANUAL**



## **CHIEF'S LIMITED ONE-YEAR WARRANTY & LIABILITY**

Chief Automotive Technologies, Inc. warrants for one year from date of installation and/or purchase any of its products which do not perform satisfactorily due to defect caused by faulty material or workmanship. Chief's obligation under this warranty is limited to the repair or replacement of products which are defective and which have not been misused, carelessly handled, or defaced by repair or repairs made or attempted by others.

**CHIEF AUTOMOTIVE TECHNOLOGIES, INC. DOES NOT ASSUME RESPONSIBILITY FOR ANY DEATH, INJURY OR PROPERTY DAMAGE RESULTING FROM THE OPERATOR'S NEGLIGENCE OR MISUSE OF THIS PRODUCT OR ITS ATTACHMENTS. CHIEF MAKES NO WRITTEN, EXPRESS OR IMPLIED WARRANTY WHATSOEVER OF MERCHANTABILITY OR FITNESS FOR A PARTICULAR PURPOSE OR OTHERWISE REGARDING THE EQUIPMENT OR ANY PART OF THE PRODUCT OTHER THAN THE LIMITED ONE-YEAR WARRANTY STATED ABOVE.**

Returned merchandise requires a "RETURNED GOODS AUTHORIZATION NUMBER" on the package. Authorization numbers can be obtained by calling or writing the Customer Service Department, Chief Automotive Technologies, Inc. No returned merchandise will be accepted without an authorization number. All returned merchandise must be shipped freight prepaid (and may be subject to a handling and restocking charge) to:

Chief Automotive Technologies, Inc.  
Attn: Returned Goods Dept.  
1924 E. Fourth St.  
P.O. Box 1368  
Grand Island, Ne. 68802  
308-384-9747

or                      Your Authorized  
Chief Automotive Technologies, Inc.  
Representative

This users manual is designed to assist operators with the safe and efficient use of the 3" (75mm) and 6" (150mm) S21M auxiliary rams. When used with Chief's S21M repair system, these auxiliary rams provide operators the capability of broadening their repair setups.

**IMPORTANT:**

- 1) This manual identifies only basic usage procedures for lifting, pulling and pushing with S21M auxiliary rams. For more detailed information, contact Chief Automotive Technologies, Inc. Training Department.
- 2) The hydraulic components of the S21M auxiliary rams are compatible with only the EZ Liner S21M repair system.

The 3 inch (75 mm) auxiliary ram is used to lift a vehicle when installing anchoring equipment and lift or support a vehicle's structural components during the repair. The 6 inch (150 mm) auxiliary ram is used for lateral pulls 360 degrees around the machine. It can also be used to make down pulls.

## BASIC OPERATING PROCEDURES

In addition to the following basic procedures, read specific 'steps' and/or 'precautions' that pertain to lifts, down pulls, lateral pulls and lateral pushes. (See text and illustrations following these procedures.)

**CAUTION:** DO NOT use auxiliary rams to lift until vehicle's wheels are blocked. DO NOT use auxiliary rams to pull or push until vehicle is secured to EZ Liner mainframe using appropriate anchoring equipment. DO NOT use auxiliary rams to anchor vehicle to mainframe.

1. Prior to usage, close auxiliary line valve and make sure male and female quick couplers are free of dirt and other contamination.
2. Attach quick couplers to ram making sure they are threaded tight. (Attach other components, i.e. v- base, flat cap, etc. as required.)  
**IMPORTANT:** Quick couplers must be fully tightened to allow flow of hydraulic oil to auxiliary ram. (See Figures 2 and 3.)

3. Place auxiliary ram at desired location.  
**CAUTION:** When putting auxiliary ram in position DO NOT place hand between base of ram and machine. Also, DO NOT place hand between ram and vehicle or ram and chain.

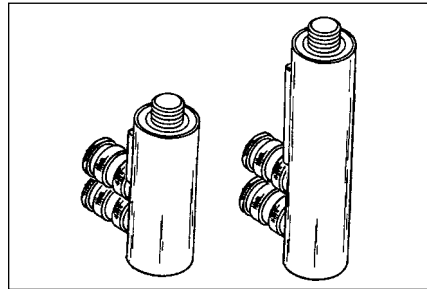

Figure 1

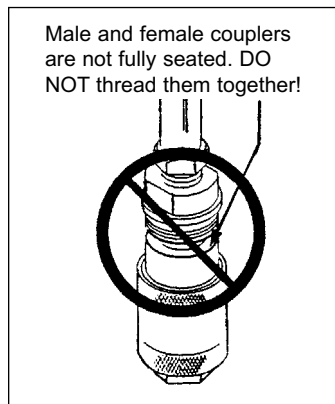

Figure 2

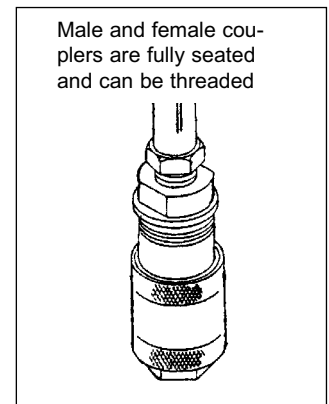

Figure 3

4. Open auxiliary line valve and close all other hydraulic valves that are not intended for use.
5. Apply just a small amount of pressure and check if auxiliary ram assembly is correctly positioned. If it isn't, release pressure and reposition.  
**CAUTION:** Before attempting to lift, pull or push with an auxiliary ram, read and follow procedures that are applicable to each usage.
6. Continue to apply pressure until desired amount of movement is achieved. Then close auxiliary line valve.  
**CAUTION:** DO NOT position yourself close to, or in line with chains, clamps, or other accessories while pressure is applied to this system. Failure to observe this warning could result in operator injury due to the possibility of a chain or accessory disengaging or failing while pressure is applied to this system.

## SPECIFIC OPERATING PROCEDURES

### LIFTS: (See Figures 4 and 5 - page 2)

1. Block vehicles wheels before making lift.
2. Position base of auxiliary ram on top of mainframe making sure that base is flush with surface of mainframe. This perpendicular positioning provides

greater vehicle stability during the lift and prevents breakage of quick coupler at base of ram.

**CAUTION:** When putting auxiliary ram in position DO NOT place hand between base of ram and machine. Also, DO NOT place hand between auxiliary ram and vehicle.

**NOTE:**

1. Whenever possible, use S21M ram base accessory for additional stability. (See Figure 5 inset.)
2. When lifting in pump lid area of EZ Liner, position 2 x 4 x 16 (50 x 100 x 400 mm) hardwood across pump lid and position base of auxiliary ram (or ram base) on top of hardwood.

**DOWN PULLS: (See Figure 6)**

**NOTE:** Auxiliary rams can be used to make down pulls through EZ Liner mainframes.

1. Attach male coupling and v-base to piston end of auxiliary ram.
2. Position base of auxiliary ram on bottom of mainframe between tie down holes. Make sure that it is flush against bottom surface of mainframe. This perpendicular positioning prevents auxiliary ram from kicking out during the pull and it prevents breakage of quick coupler at base of auxiliary ram.

**NOTE:** Whenever possible, use S21M ram base accessory for additional stability. (See Figure 6 inset.)

3. Attach chain to vehicle and place ends of chain through tie down holes on each side of auxiliary ram. Position chain around v-base attachment and secure the assembly as shown.

**CAUTION:**

1. Base of auxiliary ram must sit square (perpendicular) with bottom surface of mainframe for vehicle to remain stable during down pull.
2. DO NOT position hand between ram and bottom surface of mainframe or between ram and chain.

**LATERAL PULLS: (Figures 7 - 11, pages 3 - 4)**

Auxiliary rams can be used to make lateral pulls (side or angular) on the S21M EZ Liner. Setups for the pulls vary dependent upon type of pull required.

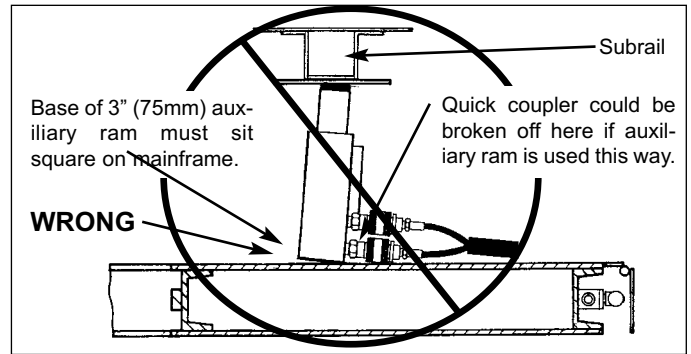

Figure 4

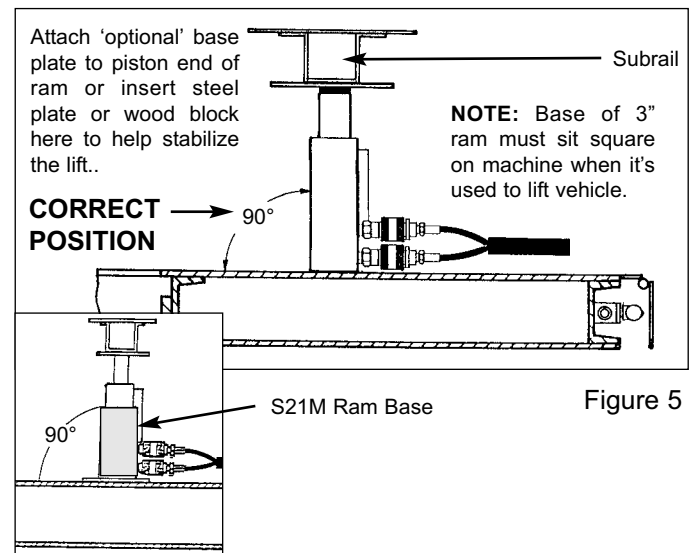

Figure 5

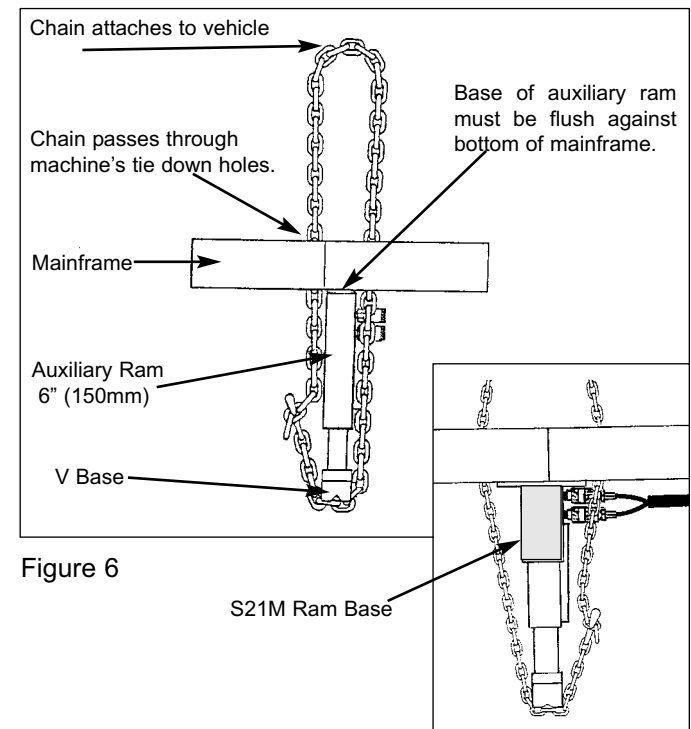

Figure 6

**Basic Setup**

**CAUTION:**

1. DO NOT use pulling system's crossmembers when making lateral pulls with auxiliary rams.
2. DO NOT position yourself close to, or in line with chains, clamps, or other accessories while pressure is applied to this system. Failure to observe this warning could result in operator injury due to the possibility of a chain or accessory disengaging or failing while pressure is applied to this system.
3. The 3/8 inch (10mm) tie down chain is proof tested to 20,000 lbs. and has a normal working load limit of 7,300 lbs.

1. Attach pulling chain to vehicle.
2. Secure v-base, male coupling and auxiliary pulling head to 6 inch (150 mm) auxiliary ram. (See Figure 7.)
3. Mount auxiliary ram assembly on top surface of mainframe.
4. Determine correct angle and height for the pull. Then position chain on auxiliary pulling head and secure it with pin.

**NOTE:** If more height is needed, add extension coupling and extension tube to assembly.

5. Secure tail of chain to mainframe.

**IMPORTANT:**

1. To avoid damage to auxiliary ram from side loading, assemble components as shown in Figure 7. Auxiliary pulling head must be positioned inward from outer edge of mainframe.
2. If using auxiliary ram as shown in Figure 8, use low pressure and watch closely so it does not bow due to side load. As more extension tubing is added, side load becomes more severe.

**CAUTION:** Always attach v-base to piston end of ram. (See Figures 7 and 8.) DO NOT add extension tubing to piston end of ram.

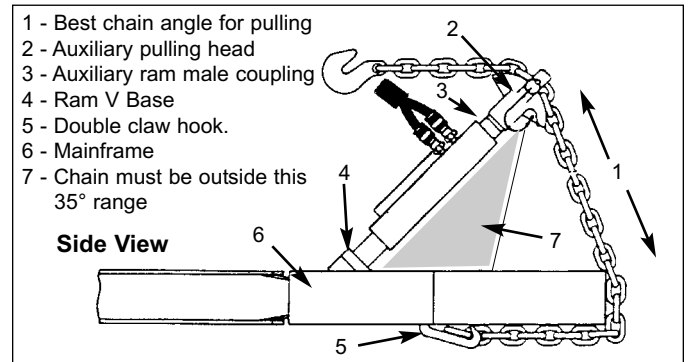

Figure 7

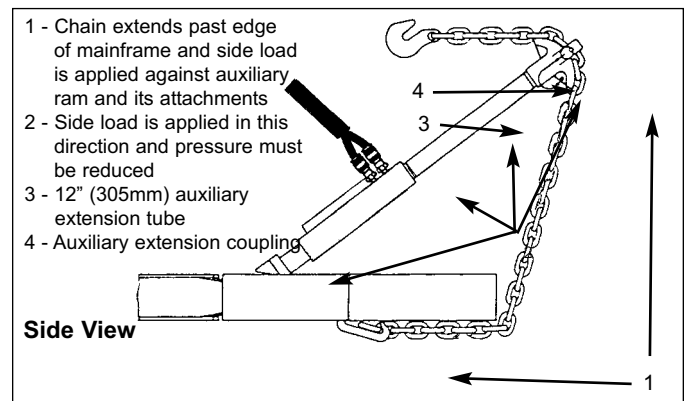

Figure 8

**Side Pulls**

1. Position v-base of auxiliary ram assembly against tie down hole (see Figure 9) or brace it against bumper puller chain that links adjacent rows of tie down holes (see Figure 10). Bumper puller must be positioned on top of mainframe with its claw hooks engaging two tie down holes.
2. Wrap tail end of pulling chain around outside edge and bottom of mainframe and secure it to lower inside edge of mainframe using handy hook or double claw hook.

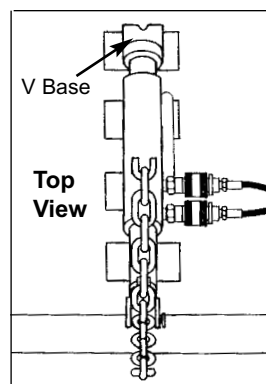

Figure 9

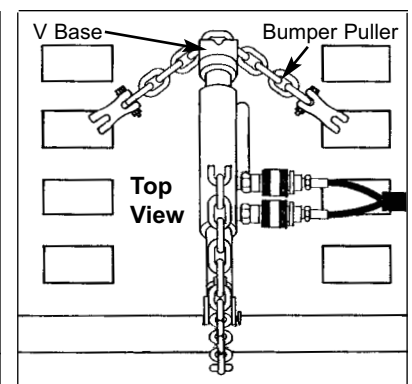

Figure 10

### Angular Pulls

1. Position auxiliary ram assembly at desired angle securing v-base attachment in corner of tie down hole. (See Figure 11.)
2. Wrap tail end of pulling chain around outer edge of machine and secure it to tie down hole on underside of mainframe using handy hook or double claw hook.  
**IMPORTANT:** Tail end of chain must be secured at opposite angle to auxiliary ram. (See also Figure 11.)

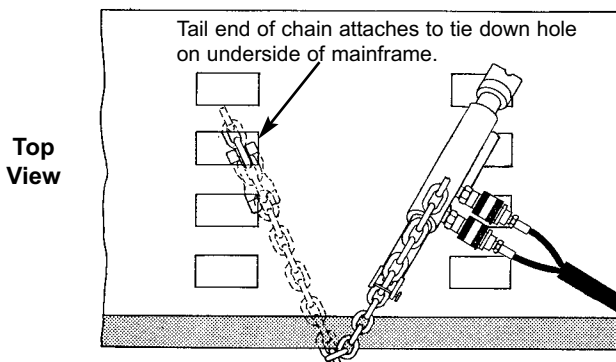

Figure 11

### LATERAL PUSHES: (Figures 12 and 13)

Lateral pushes are only allowed on S21M repair systems provided they are done according to prescribed procedures.

1. Move EZ Liner tower into position and bolt it to outer tie down hole on mainframe. (See Figure 12.)
2. Lower collar to approximately 3" (75mm) above tower gusset.
3. Position tower chain hook in tie down hole approximately 18" (460 mm) in from outside edge of mainframe. Then lower collar to remove slack chain. (See also Figure 12.)
4. Apply 1.5 ton (210 bar) on tower chain and then close tower valve.
5. Secure v-base to piston end of 6" (150mm) auxiliary ram and attach extension couplings and appropriate length extension tube to opposite end of auxiliary ram. Then attach serrated saddle (or v-base) to end of extension tube to protect it when pushing against vehicle. (See Figure 13.)

6. Position v-base (at piston end of ram) against tower chain and extension tube assembly against vehicle. (See Figure 13.)

7. Apply pressure.

**CAUTION:** DO NOT position yourself close to, or in line with chains, clamps, or other accessories while pressure is applied to this system. Failure to observe this warning could result in operator injury due to the possibility of a chain or accessory disengaging or failing while pressure is applied to this system.

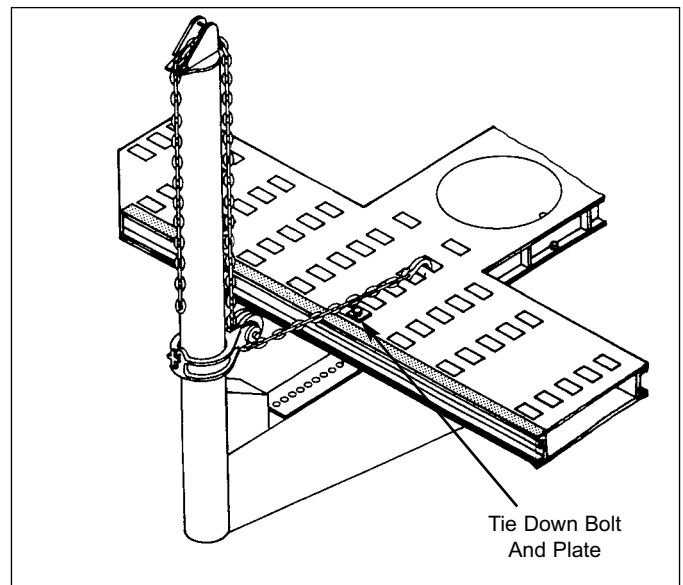

Figure 12

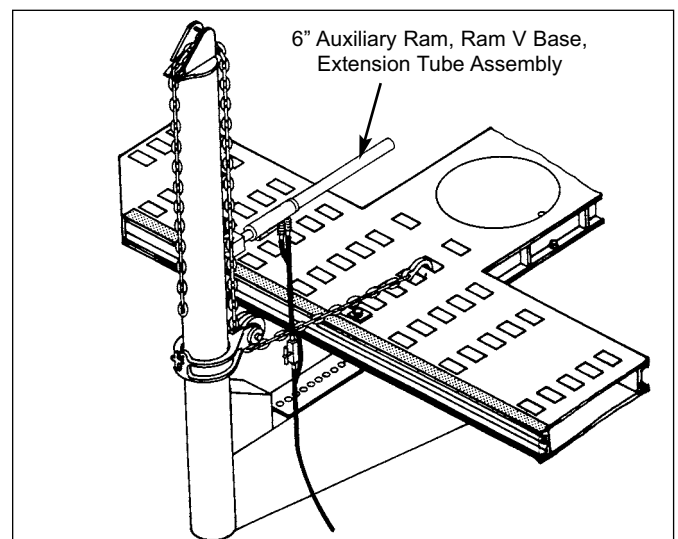

Figure 13

## PARTS INFORMATION

To order replacement parts for Chief Auxiliary Rams, contact Chief Automotive Technologies, Inc., 800-445-9262. (If outside the United States, contact your nearest Chief Automotive Technologies, Inc. representative.)

When contacting Chief Automotive Technologies, Inc. by telephone or mail, provide the following information: name, name of business, business telephone number, and business address. Additional information needed when ordering: description of part(s) and part number(s).

**CAUTION:** Always use Chief Automotive Technologies, Inc. authorized replacement parts with the Auxiliary Tower System. When replacing any part make certain the part meets the original equipment requirements.

Ref.	Part No.	Description
1	601194	Aux. Ram, 2 1/2 Bore, 3 1/4" Stroke
2	601195	Aux. Ram, 2 1/2 Bore, 6" Stroke
3	601020	Quick Coupler, Female, Black
4	601018	Quick Coupler, Female, Yellow
5	620840	Ram Flat Cap, T.T.C. — 201362
6	602618	Threaded Adapter, YS107, O.T.C. 20471
7	602319	Threaded Male Connector
8	602335	Ram V-Base
	601105	Cylinder Repair Kit (does not include Part Nos. 602319 and 602335)
<b>Other auxiliary line components frequently ordered</b>		
	<b>601040</b>	<b>Auxiliary Line Assembly, S21M</b>
9	602802	Auxiliary Ram Line Valve
10	601039	Long Hose Protector, S21M Aux. Line
11	601019	Quick Coupler, Male, Yellow
12	601021	Quick Coupler, Male, Black
13	601037	Hose, 218"
14	601036	Hose, 170"
15	601035	Hose, 45"
16	601038	Short Hose Protector, S21M Aux. Line
17	601140	Ram Base, S21M

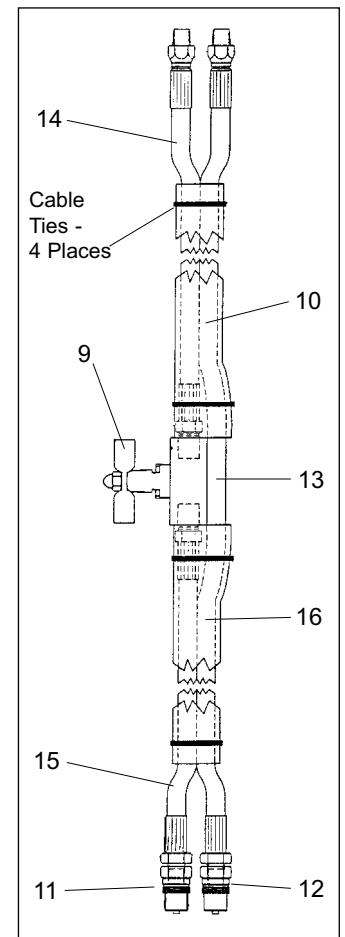
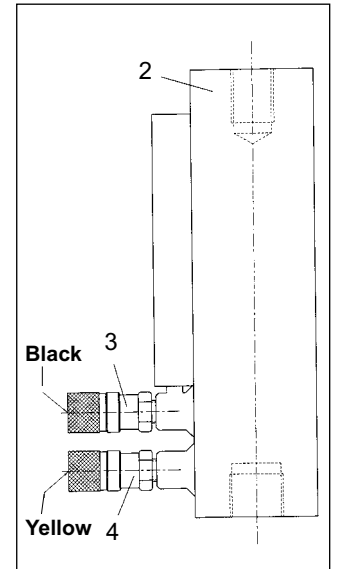
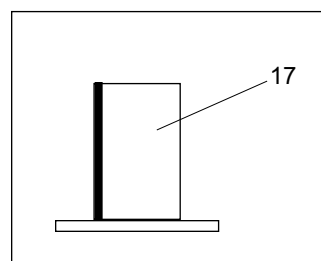
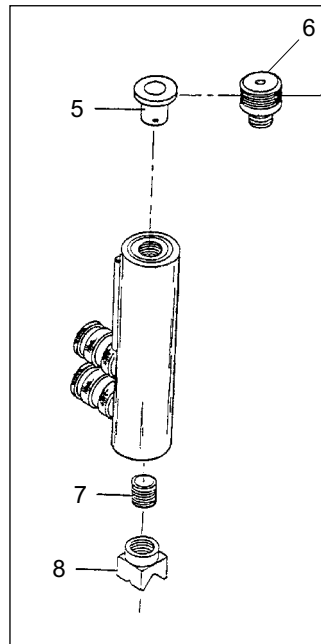
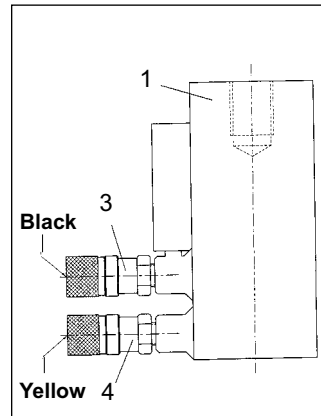



**P.O. Box 1368  
Grand Island, Nebraska 68802-1368  
Phone: 308/384-9747  
Fax: 308/384-8966**

**[www.chiefautomotive.com](http://www.chiefautomotive.com)**

**Chief reserves the right to alter product specifications  
and/or package components without notice.**