

Universal Anchoring Adapter For Mercedes

Anchoring Pin & Tube Set
(For Most Mercedes Models)

Users Manual





CHIEF'S LIMITED ONE-YEAR WARRANTY & LIABILITY

Chief Automotive Technologies, Inc. warrants for one year from date of installation and/or purchase any of its products which do not perform satisfactorily due to defect caused by faulty material or workmanship. Chief's obligation under this warranty is limited to the repair or replacement of products which are defective and which have not been misused, carelessly handled, or defaced by repair or repairs made or attempted by others.

CHIEF AUTOMOTIVE TECHNOLOGIES, INC. DOES NOT ASSUME RESPONSIBILITY FOR ANY DEATH, INJURY OR PROPERTY DAMAGE RESULTING FROM THE OPERATOR'S NEGLIGENCE OR MISUSE OF THIS PRODUCT OR ITS ATTACHMENTS. CHIEF MAKES NO WRITTEN, EXPRESS OR IMPLIED WARRANTY WHATSOEVER OF MERCHANTABILITY OR FITNESS FOR A PARTICULAR PURPOSE OR OTHERWISE REGARDING THE EQUIPMENT OR ANY PART OF THE PRODUCT OTHER THAN THE LIMITED ONE-YEAR WARRANTY STATED ABOVE.

Universal Anchoring Adapter For Mercedes

The Universal Anchoring Adapters for Mercedes secure most Mercedes models that have jack tubes in the side of their rocker panels and lift tabs on the underside of their rocker panel. This system provides a positive means of securing these vehicles to the EZ Liner mainframe.

IMPORTANT:

- 1) Information on use of anchoring stands (including their attachment to the EZ Liner mainframe) appears in the Universal Anchoring Systems Users Manual. (Part No. 618740.)
- 2) Read all of the following instructions prior to using the Universal Anchoring Adapter for Mercedes.

PREPARATION

1. Remove all tubes and pinchweld clamps from the base of each anchoring stand and install an anchoring adapter tube (see Figure 1) in each base. Figure 2 shows the relationship of the tube to the anchoring stand and to the vehicle's rocker panel.
2. Clean jack tubes using one of the anchoring pins. (See Figure 3.)
 - a. Insert a steel punch (or bar) through the 1/2 inch hole at end of pin and use it as a handle.
 - b. Rotate pin right and left as it is moved in and out of jack tube hole.

NOTE: Holes must be clean to allow for easy installation and removal of the anchoring assembly.

IMPORTANT: DO NOT use force to drive pin into jack tube hole. Using force to drive pin into the hole may make it difficult (or impossible) to remove the pin.

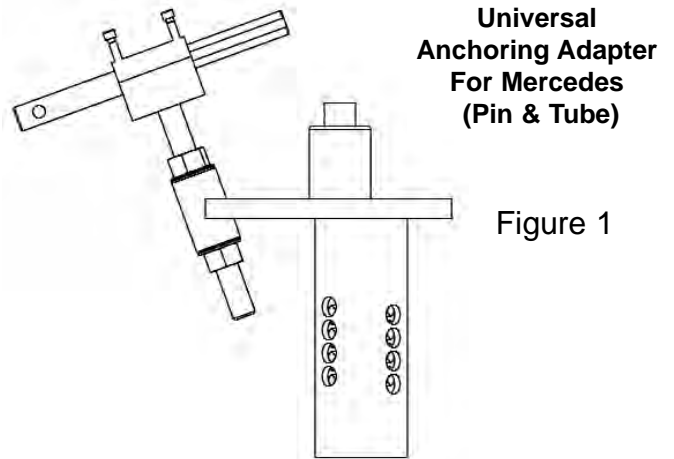

Figure 1

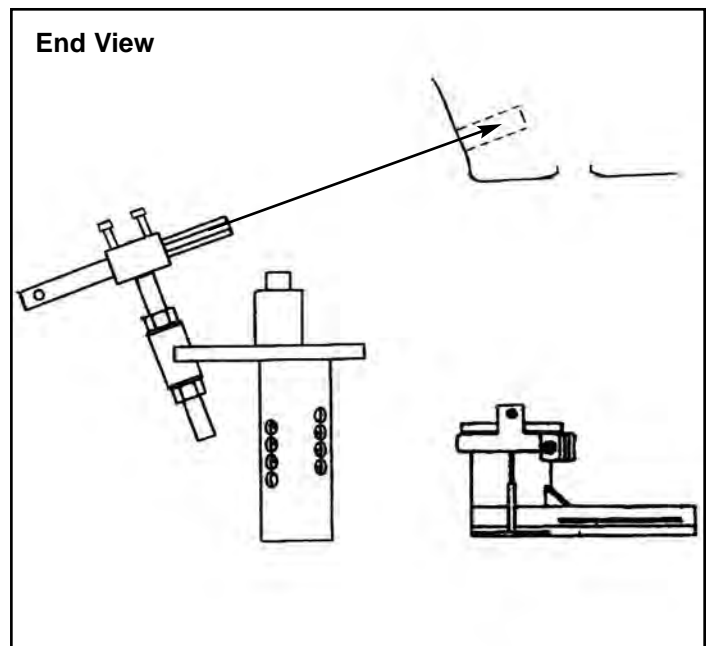
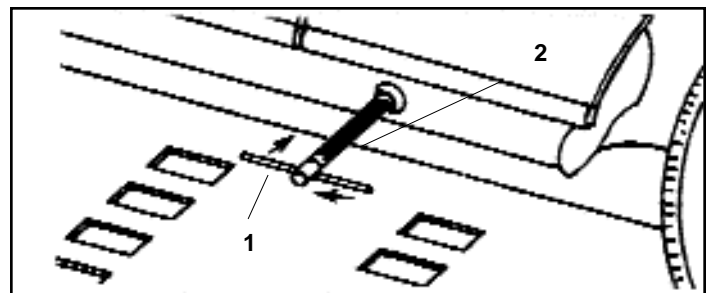

Figure 2



- 1) Steel Punch (Or Bar)
- 2) Anchoring Pin

Figure 3

INSTALLATION

1. Lift one side of vehicle using a suitable lifting device.

CAUTION: Block vehicle's wheels and set emergency brake before lifting vehicle.

2. Install post on anchoring pin adapter tube and place tube in anchoring stand base.

NOTE: The post may be positioned in one of two locations depending upon location of lift tab hole on underside of rocker panel.

3. Position anchoring stand under rocker panel making sure its locator plate fits securely in one of the main-frame's tie down holes.

4. Adjust height of the tube and fully engage the post with the lift tab hole on underside of rocker panel. (See Figure 4.) Then insert Anchoring stand's height adjustment pin to prevent the assembly from dropping out of position.

5. Adjust height of the anchoring pin support to align with jack tube hole on side of rocker panel. (See Figure 5.) Secure this support by tightening its two 3/4 nuts.

IMPORTANT: Anchoring Pin Support must be close to but not touching the rocker panel. (See Arrow - Figure 5.)

6. Loosen thumb screws on top of support and insert anchoring pin through the support and into the jack tube. Then retighten the thumb screws.

IMPORTANT: The pin must fully engage the jack tube and anchoring pin support must be close to but not touching the rocker panel. Also, the post must fully engage the lift tab hole. (See Figures 7 and 8 which show correct and incorrect installation.)

7. Repeat the procedure at the other corners of the vehicle's center section

8. Recheck all anchoring stands and adjust the height of the anchoring tubes as needed. All four locations must be secured at identical datum height dimensions.

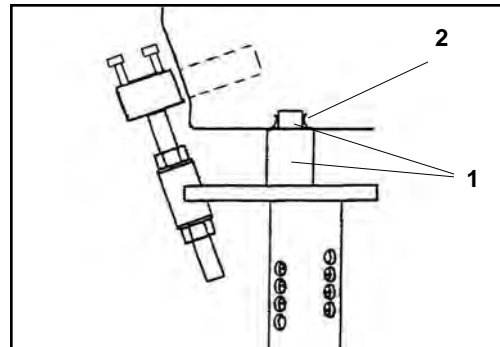

Figure 4

- 1) Post
- 2) Lift Tab

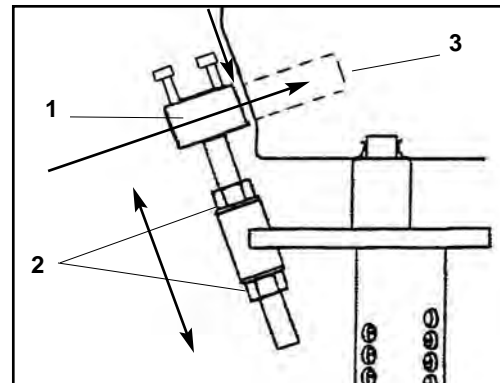
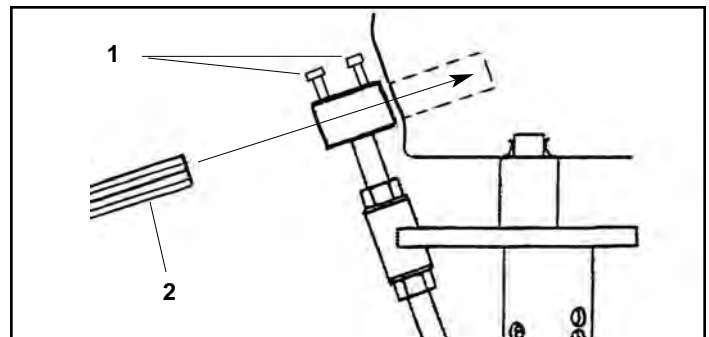

Figure 5

- 1) Anchoring Pin Support
- 2) 3/4 inch nuts
- 3) Jack Tube



- 1) Thumbscrew
- 2) Anchoring Pin

Figure 6

Correct

Incorrect

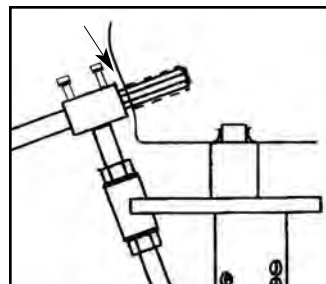

Pin is fully inserted and anchoring pin support is close to but does not touch rocker panel.

Figure 7

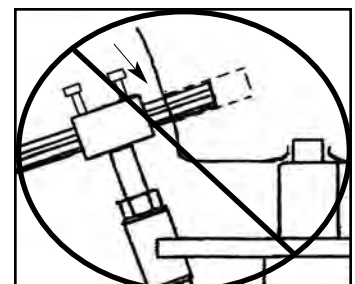

Pin is not fully inserted and anchoring pin support is too far away from rocker panel.

Figure 8

9. Secure anchoring stand bases to EZ Liner mainframe using fastener plates and tie down bolts.

NOTE: The securing of anchoring stand bases to the mainframe must be in accordance to the repair plan.

PARTS INFORMATION

To order parts for Chief's Universal Mercedes Anchoring Adapter contact Chief Automotive Technologies, Inc., 1924 East 4th Street, Grand Island, Ne. 68802, 800-445-9262 and refer to part numbers.

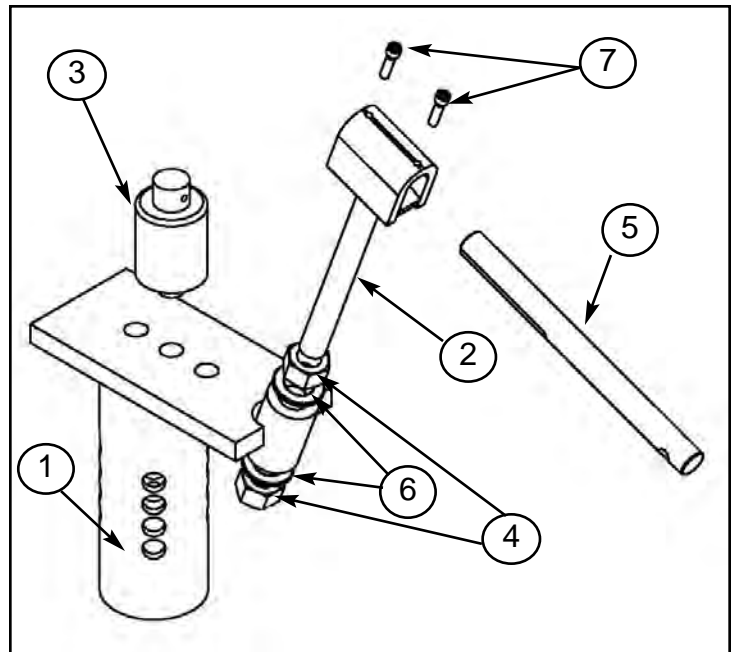

Ref.	Qty.	Part No.	Description
		519558	Mercedes Adapter, Set of 4
1	1	519551	Tube & Base Weldment
2	1	519552	Threaded Rod Pin Support Weldment
3	1	519533	Adapter Post
4	2	601720	Nut, 3/4-10 NC
5	1	618302	Anchoring Pin
6	2	601738	Washer, 3/4 Flat
7	2	011056	Screw, 1/4-20x1" Socket Head Cap
*		539300	Box, F.A.S.T. Anchoring
*		519730	Anchoring Tool Box

* Not shown in illustration



P.O. Box 1368
Grand Island, Nebraska 68802-1368
Phone 308-384-9747
Fax 308-384-8966

www.chiefautomotive.com

**Chief reserves the right to alter product specifications and/or
package components without notice.**