

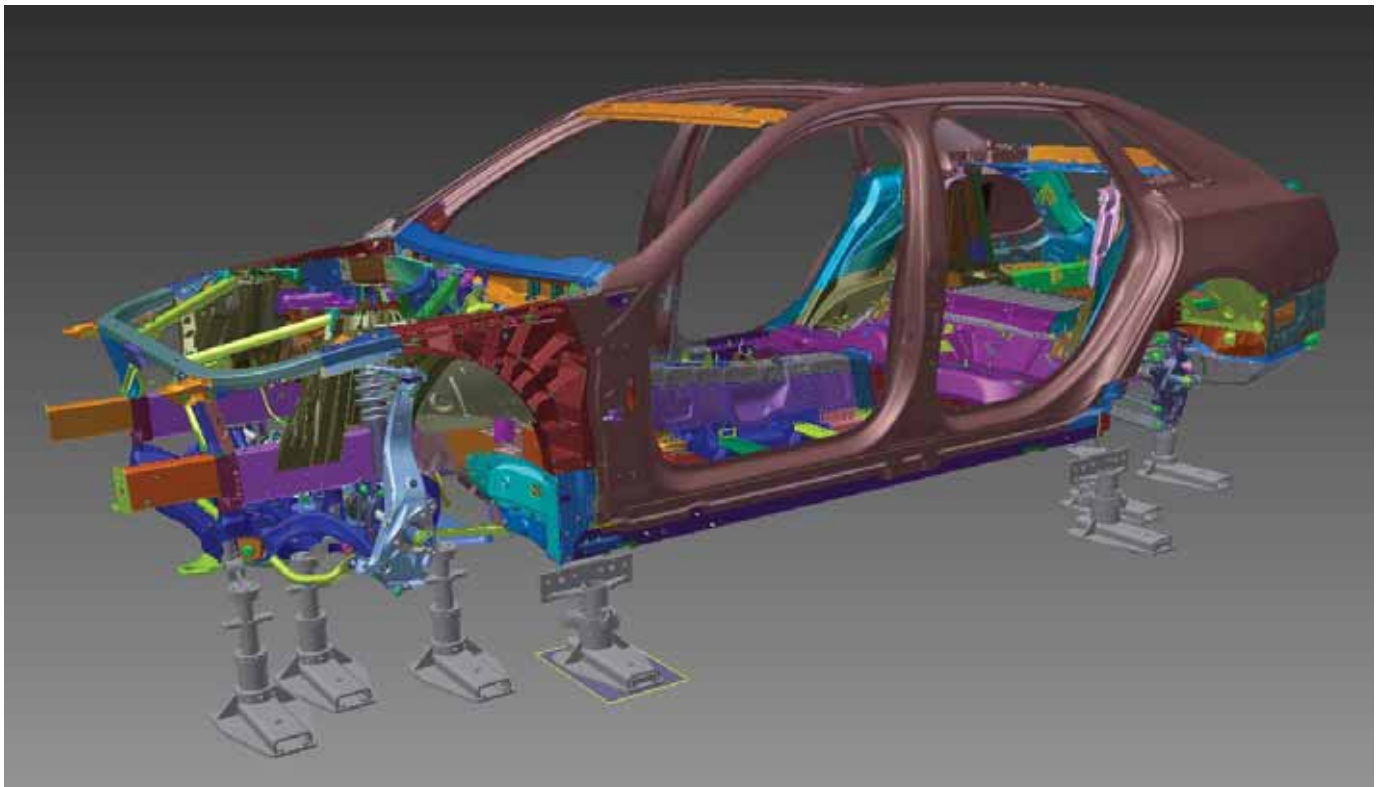

CT6 Structural Holding System

Users Manual



CHIEF'S LIMITED ONE-YEAR WARRANTY & LIABILITY

Chief Automotive Technologies warrants for one year from the date of installation and/or purchase any of its products which do not perform satisfactorily due to defect caused by faulty material or workmanship. Chief's obligation under this warranty is limited to the repair or replacement of products which are defective and which have not been misused, carelessly handled, or defaced by repairs made or attempted by others.

CHIEF AUTOMOTIVE TECHNOLOGIES DOES NOT ASSUME RESPONSIBILITY FOR ANY DEATH, INJURY OR PROPERTY DAMAGE RESULTING FROM THE OPERATOR'S NEGLIGENCE OR MISUSE OF THIS PRODUCT OR ITS ATTACHMENTS. CHIEF MAKES NO WRITTEN, EXPRESS OR IMPLIED WARRANTY WHATSOEVER OF MERCHANTABILITY OR FITNESS FOR A PARTICULAR PURPOSE OR OTHERWISE REGARDING THE EQUIPMENT OR ANY PART OF THE PRODUCT OTHER THAN THE LIMITED ONE-YEAR WARRANTY STATED ABOVE.

This users manual is designed to assist operators with the safe and efficient use of the Chief CT6 Structural Holding System. When used with Chief Electronic Measuring, the parts holding system provides operators with the ability to accurately and securely hold replacement parts during vehicle repair.

IMPORTANT:

This manual only identifies basic usage procedures for the CT6 Structural Holding System, it must be used with the Chief Structural Holding System. The usage of the system is limited only by the imagination of the technician doing the work.

The Chief CT6 Structural Holding System is designed for the holding and positioning replacement parts. It is not designed as a replacement for Chief Anchoring. The CT6 Structural Holding System must not be subjected to heavy pulling forces. The Chief Universal Anchoring Stands provided with the rack will still serve as the primary vehicle anchoring.

Because Chief CT6 Structural Holding System works with Chief electronic measuring, special attention should be given to the replacement of the Structural Holding stands during setup. Best results will be achieved with the stands located on the perimeter of the vehicle being repaired to prevent shading of measuring targets.

PLANNING AND SETUP

The Holding System is a universal system that will adapt to any Chief style systems with rectangular holes in the deck. The Fixtures are designed to be bolted to any existing threaded bolt or any location there is a threaded nut, flange or boxed rail on a vehicle. This could be used with suspension (components) that are installed or removed and are designed with an offset to also be used with Chiefs computerized measuring system. The system includes short vertical fixtures and tall vertical fixtures that will accommodate most bolts or threaded holes from 10mm to 25mm with the use of bushings. The large and tall horizontal fixtures are designed for any bolts or bolt hole ranging from 10mm to 25mm with the use of bushings that is facing forward, inward, outward or rearward.

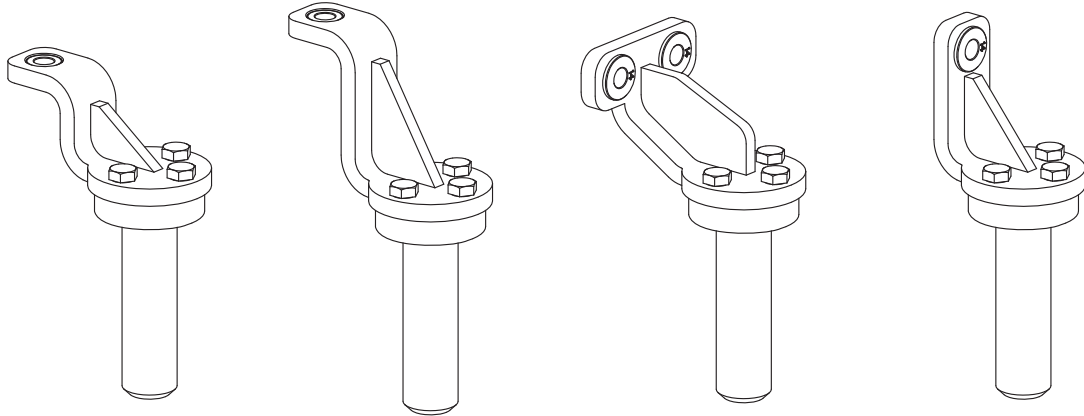

Additional attachments will allow for connection of the fixture to the structure in several different methods. The angle adapter allows for the location of the fixture to be used if the location is at an angle.

Note: All bushings are designed to allow for the correct sizing of the hole for the bolt to be used to allowing for centering of the Fixture and should be placed on the opposite side of the fixture away from the structure.

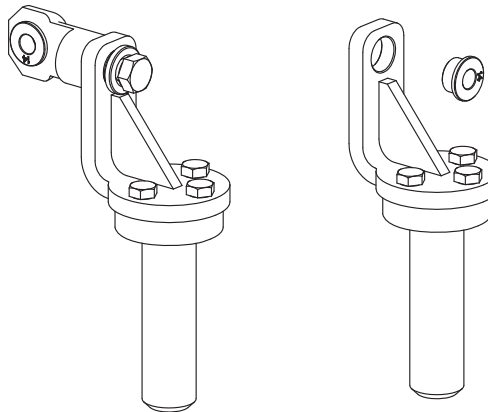

A heavy three-ear rigging nut can be placed directly below the foundation adapter. This will serve as a cable tie off when additional stability is needed.

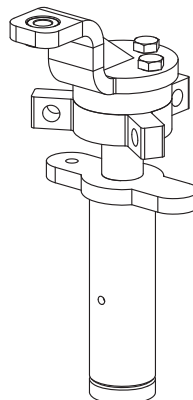

Directly below the foundation adapter is the turnbuckle adjustment mechanism. The foundation adapter threaded stud screws into the top of the turnbuckle center section while the Structural Holding lower adapter screws into the bottom. A two-ear wing nut is threaded on to the foundation adapter to lock the top half of the turnbuckle once correct vertical position is achieved. A three-ear wing nut is threaded on the lower adapter to lock that half of the turnbuckle.

Note: The long threaded portion of the Structural Holding lower adapter utilizes a left hand thread, which is compatible with the bottom of the turnbuckle center section (marked with a v-groove around the outside of the part) and the three-ear wing nut.

Turnbuckle Assembly

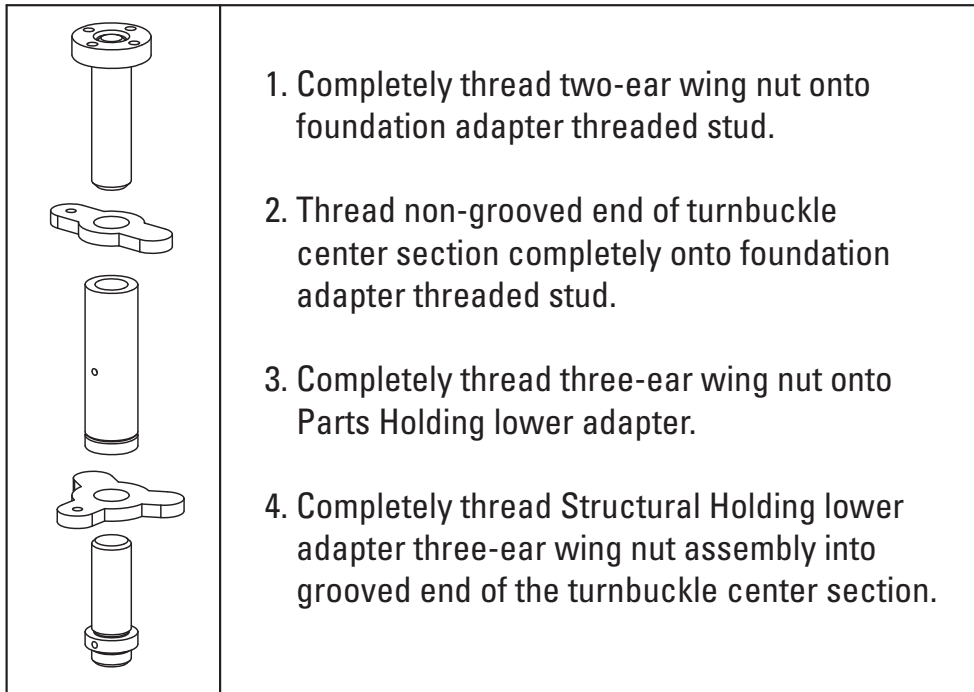

The short threaded side of the Structural Holding lower adapter is a standard right hand thread that is compatible with the Structural Holding stand base and extension tubes.

Note: It is not necessary to completely disassemble the turnbuckle section when changing setups or reconfiguring the stand. The fully assembled turnbuckle section can be unscrewed from the rest of the stand system using the included spanner wrenches.

Note: For best results, always have foundation adapter and the lower Structural Holding adapter threaded into the turnbuckle center section equal amounts before starting up.

Vertical positioning of the CT6 Structural Holding System, when used in conjunction with the Structural Holding System, uses a turnbuckle style adjustment over a 4.5" (115mm) range. Additional height can be achieved by using the extension tubes and extension adapters included with the system. Compare the approximate height required to the table below to determine how to configure the extension tubes and adapters.

502000
SHORT VERTICAL
FIXTURE

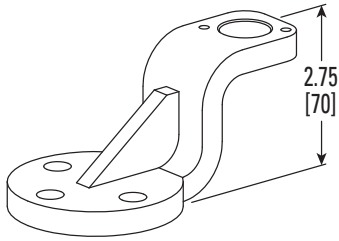

502008
TALL VERTICAL
FIXTURE

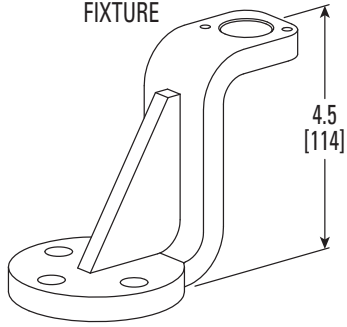

502005
LARGE HORIZONTAL
FIXTURE

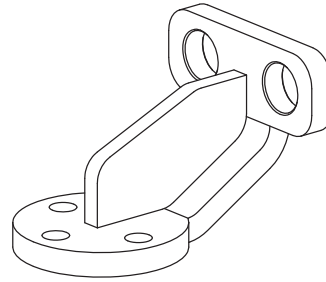

502019
TALL HORIZONTAL
FIXTURE

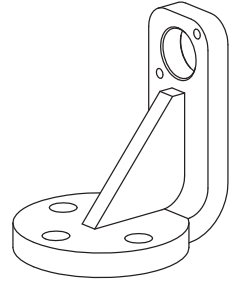

502074
FLAT FIXTURE

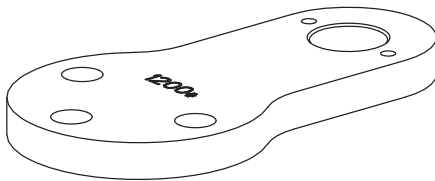

540102
40mm TORQUE BOX
W/ BRACKET

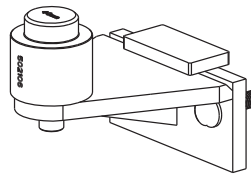

540103
25mm TORQUE BOX
W/ BRACKET

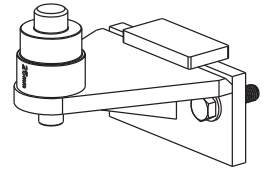

502080
CT6 FIXTURE
PEG CT6

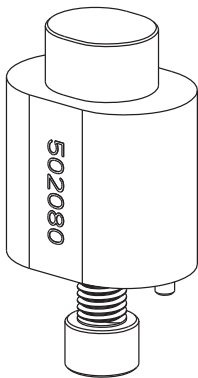

502077
19mm BOLT
BUSHING MOUNT

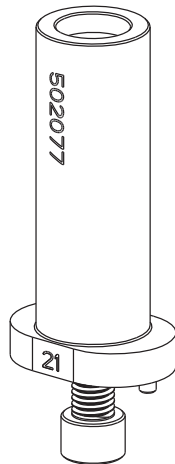

502104
PILOT
BUSHING MOUNT

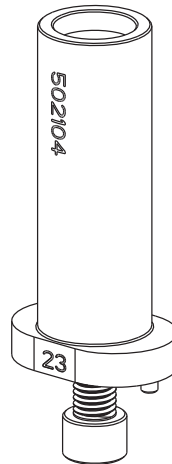

502132
A-PILLAR
MOUNT

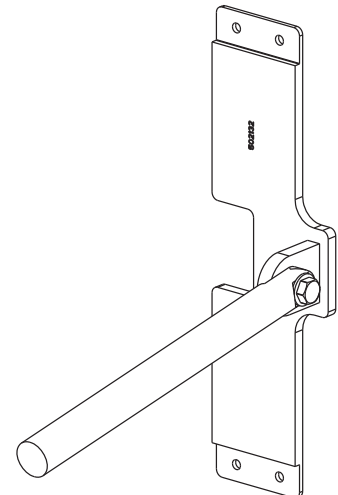

502143
PILLAR CLAMP
ASSEMBLY

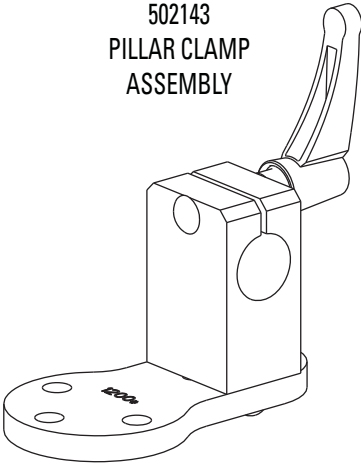

502136
B-PILLAR FIXTURE
RIGHT

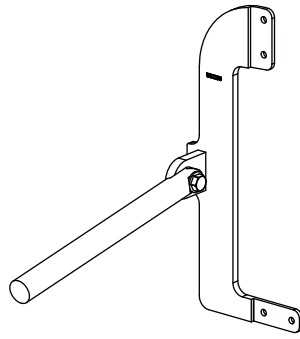

502140
PILLAR FIXTURE
LEFT

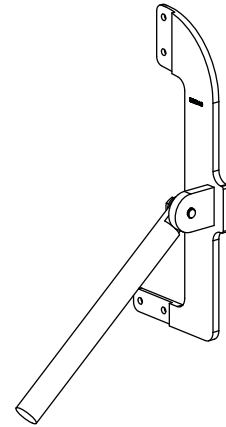

502120
STRUT TOWER FIXTURE
FRONT LEFT

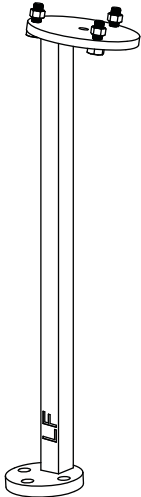

502125
STRUT TOWER FIXTURE
FRONT RIGHT

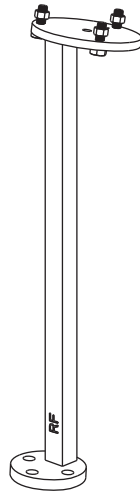

502110
STRUT TOWER FIXTURE
REAR LEFT

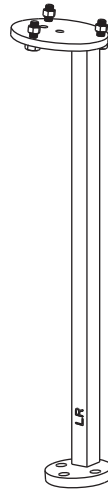

502117
STRUT TOWER FIXTURE
REAR RIGHT

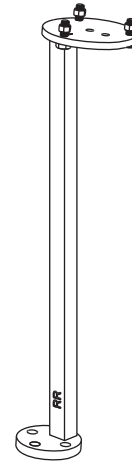

502026
ANGLE ADAPTER
CLAMP

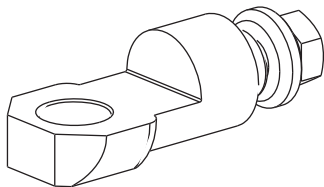

502047
STRUCTURAL HOLDING
BASE

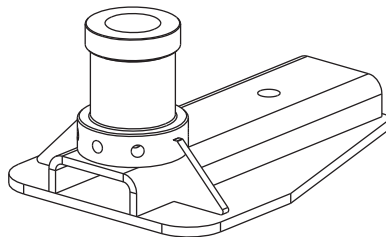

502128
NARROW STRUCTURAL
HOLDING BASE ASSY

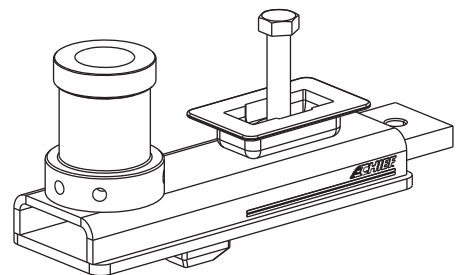

502055
SHORT TUBE
BASE STAND

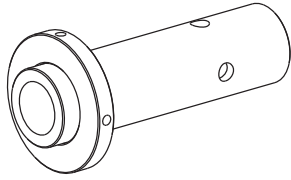

502063
TALL TUBE
BASE STAND

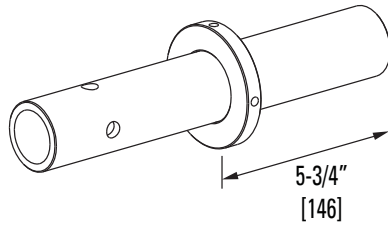

502075
11-1/2\" TUBE
BASE STAND

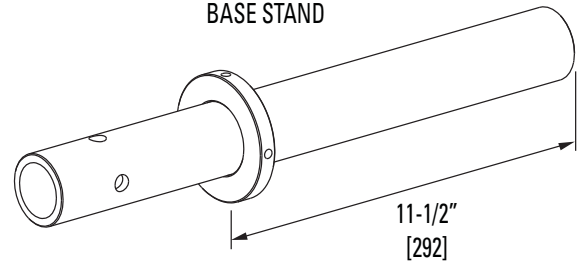

502082
3-3/4\" TUBE
BASE STAND

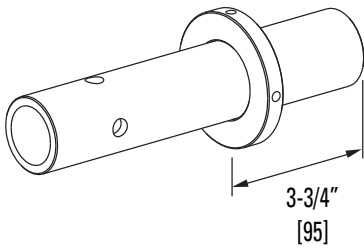

502147
18\" TUBE
BASE STAND

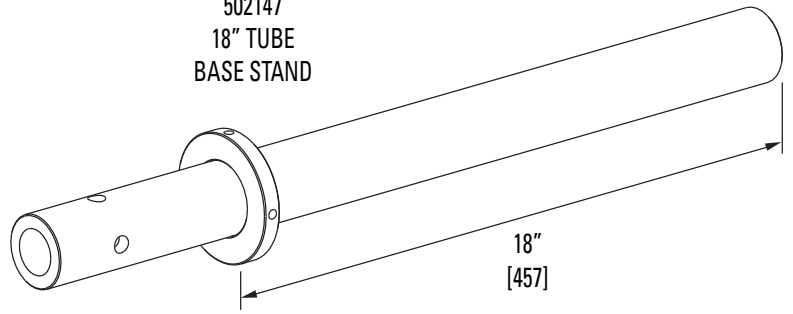

502016
4\" EXTENSION
TUBE

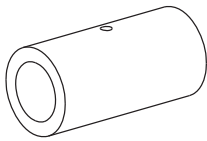

502061
10\" EXTENSION
TUBE

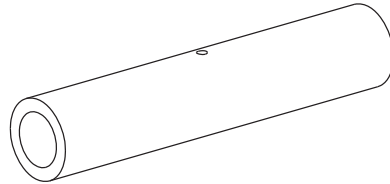

502017
12\" EXTENSION
TUBE

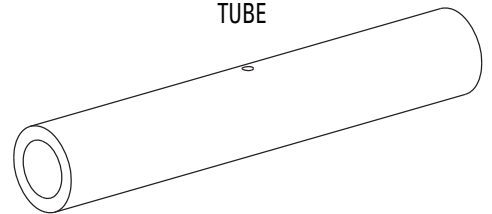

502034
TURN BUCKLE
CENTER TUBE

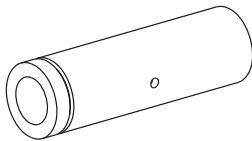

502039
ADAPTER HEIGHT
SCREW

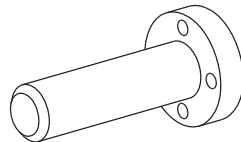

502033
LOWER ADAPTER
SCREW

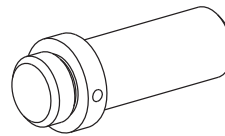

502032
ADAPTER
EXTENSION

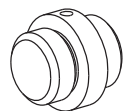

502015
RIGHT HAND
WING NUT

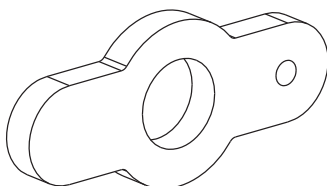

502014
LEFT HAND
WING NUT

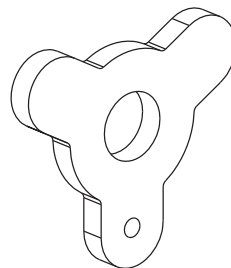

502038
RIGGING NUT

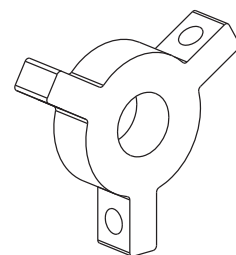

41684
M12-1.75 x 30 HHCS

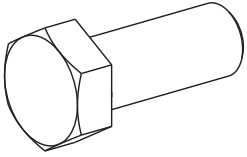

502078
M12-1.75 x 35 SHCS

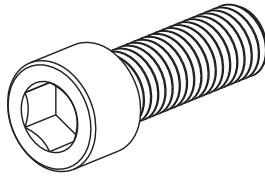

502085
M12-1.75 x 45 SHCS

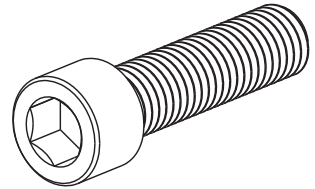

502112
M10 x 1.25 HEX NUT

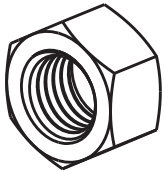

502111
M10-1.25 x 30 HHCS

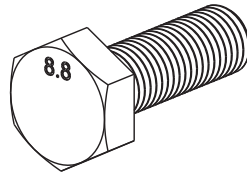

502058
RELEASE PIN

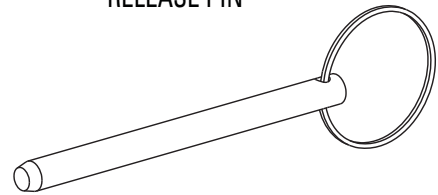

780104
MAGNETIC BOLT
ATTACHMENT 16mm

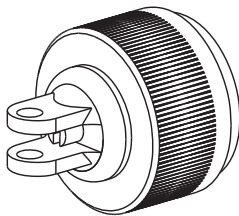

502101
THREAD-IN TARGET
ATTACHMENT M12 x 1.75

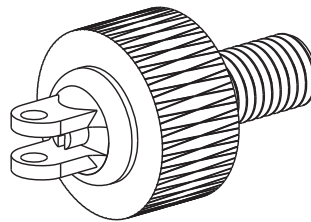

502086
PILOT BUSHING
8mm

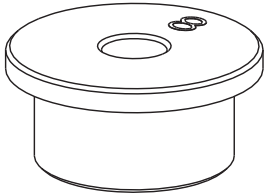

502027
PILOT BUSHING
10mm

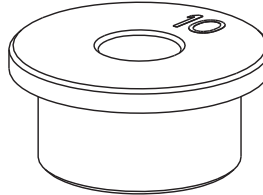

502028
PILOT BUSHING
12mm

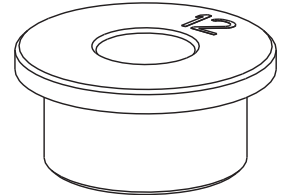

502029
PILOT BUSHING
14mm

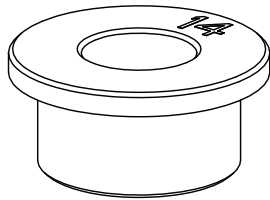

502030
PILOT BUSHING
16mm

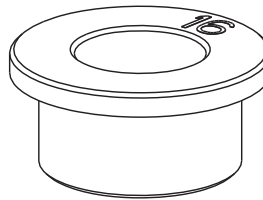

502035
PILOT BUSHING
18mm

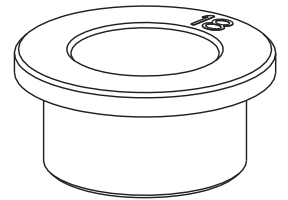

502036
PILOT BUSHING
20mm

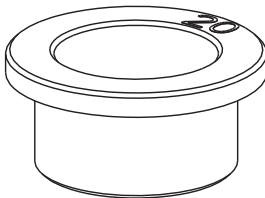

502037
PILOT BUSHING
22mm

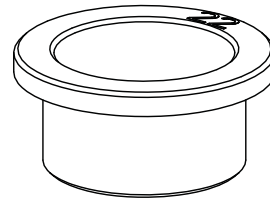

Once the proper configuration has been determined, assemble the required Structural Holding components on the base stand. The base stand should be loosely secured to the frame machine deck using M20x2.5 hardware and a UAS fastener plate. The M20x2.5 hardware will be fully tightened after the Structural Holding stand is located properly. Once the Structural Holding components are assembled, they can be fully tightened using the included spanner wrenches.

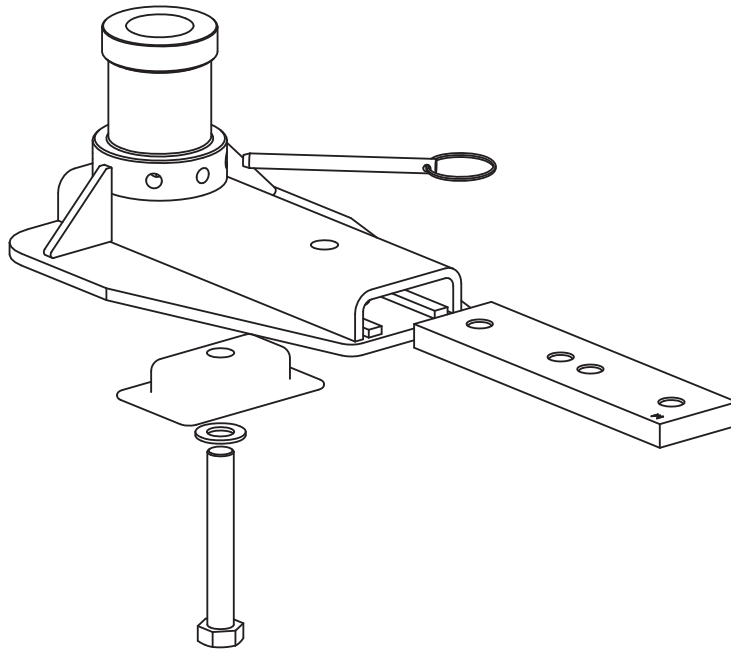

Securing New Part

Secure the replacement part to the Structural Holding stand using the foundation adapter and fixtures. Horizontal adjustment of the part can be made by lightly tapping on the stand base. Once the part is located correctly in both horizontal directions, torque down the stand base using a 30 mm wrench or socket. Vertical adjustment of the parts is achieved by turning the clockwise rotation will raise the stand. The turnbuckle section should turn easily by hand, but there is a provision to use a spanner wrench if necessary. Once the part is at the proper vertical position, tighten the top and bottom wing nuts to lock the turnbuckle center section in place and insert the release pin into one of the three hole positions.

Note: For best results, the two-ear and three-ear wing nuts should be threaded away from the turnbuckle center section when making vertical position adjustments.

CT6 Parts-On

Positioning of the vehicle on the deck is very important, and the vehicle should be carefully located on the frame machine based on the type, severity and location of the damage. Once positioned, refer to your manual for proper installation and set-up procedures.

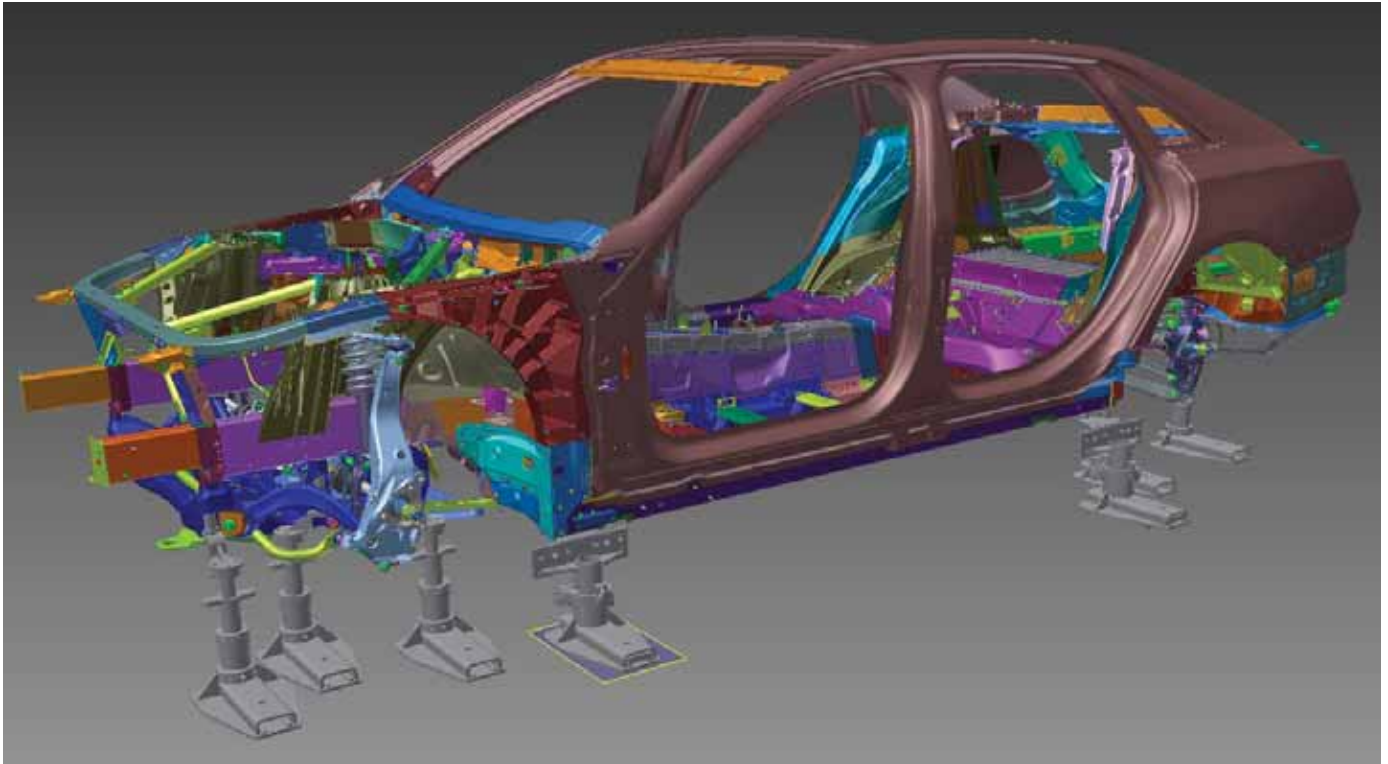

1. The initial setup requires four center section locations to be installed. Two in the front of the center section and two in the rear of the center section. Additionally, at least one set of fixtures must be placed on the front and rear rails, for a total of eight point holding for entire vehicle, see example below.

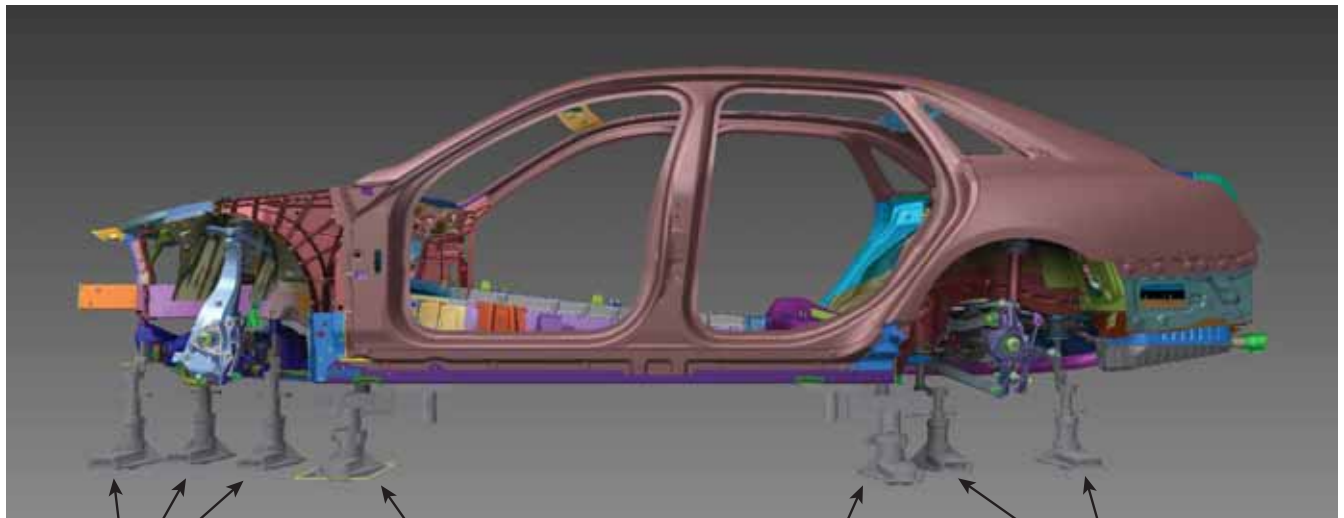

POSSIBLE HOLDING
LOCATIONS IN FRONT
SECTION ENGINE
COMPARTMENT

HOLDING LOCATION
IN FRONT OF CENTER
SECTION

HOLDING LOCATION
IN REAR OF CENTER
SECTION

POSSIBLE HOLDING
LOCATIONS IN REAR
SECTION

Center Section Base Mounting Locations

1. Torque box bracket adapters will need to be mounted to anchor stands.
2. The top hole facing outward will be used on all four locations of center section.

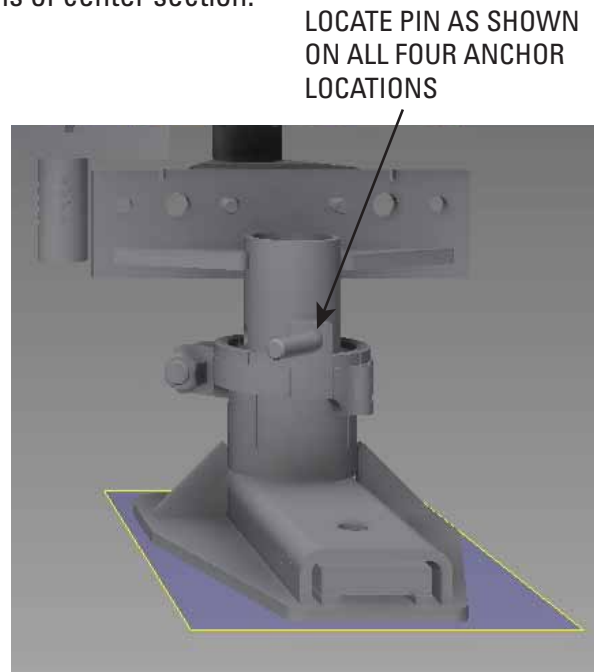
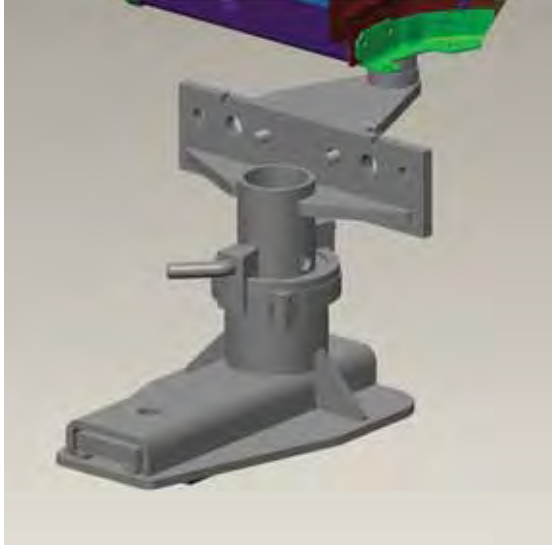

Center Front Base Mounting Location

1. Front center point uses the 40mm hole to the outside next to the rocker flange.

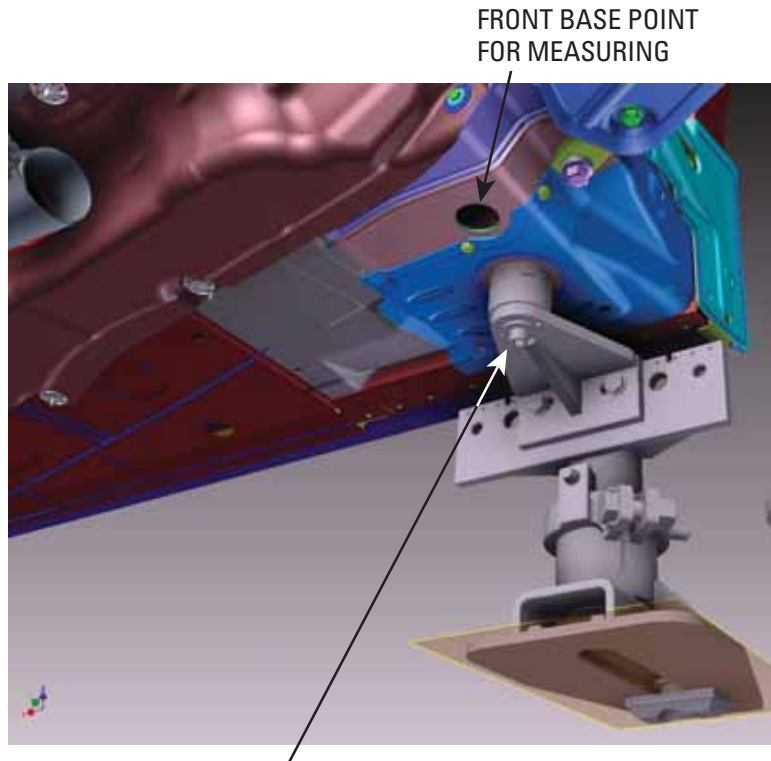

FRONT TORQUE BOX
W/ BRACKET 40mm
540102

Center Rear Base Mounting Location

1. Rear center point uses 25mm hole inside next to rocker flange.

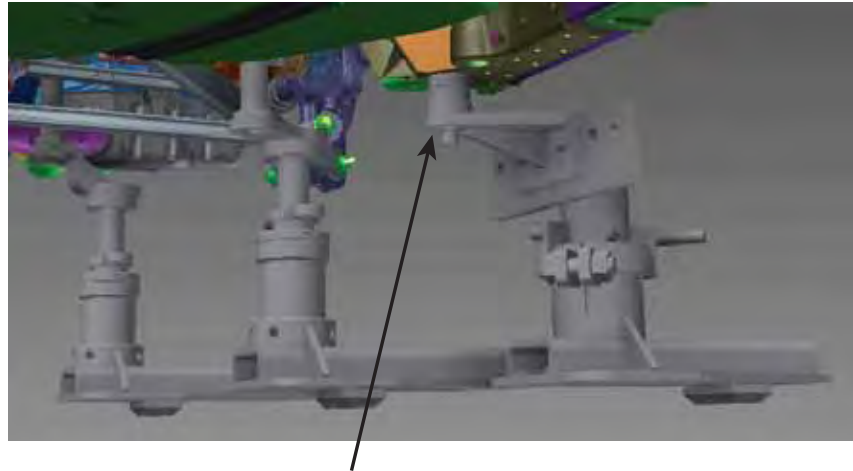

REAR TORQUE BOX
W/ BRACKET 25mm
540103

Bottom View Rear Torque Box Locate in Hole as Shown

REAR BASE POINT
FOR MEASURING

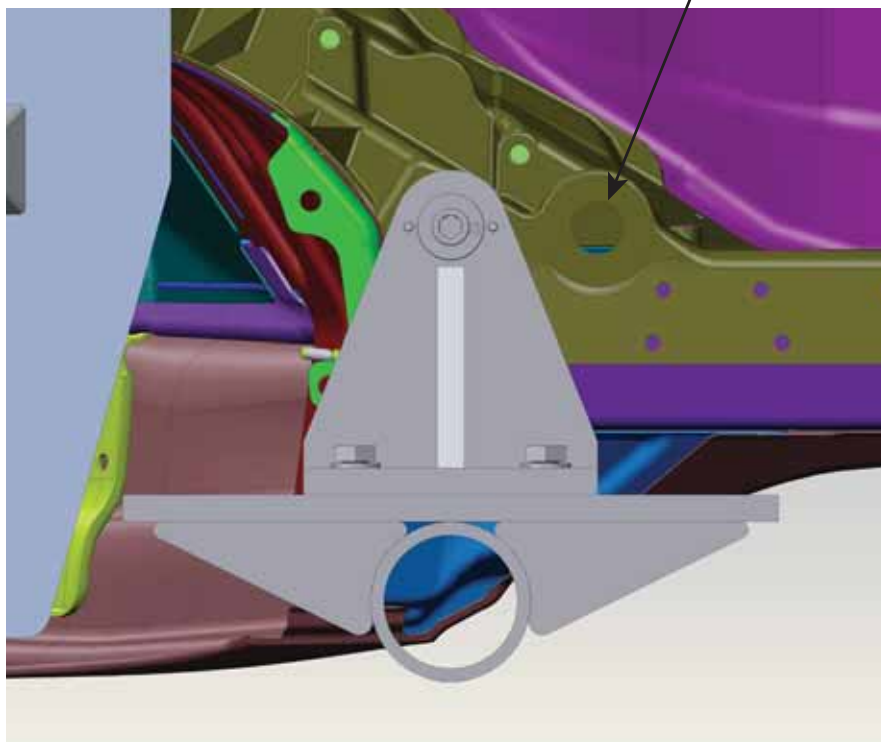

Front Suspension Mounting Location

On the front section, additional holding can be located on the engine cradle bolt locations front, middle, or rear without main parts removed. With removal of the front bumper cover and absorber, holding can be located at the end of the rail.

Left Front Parts On

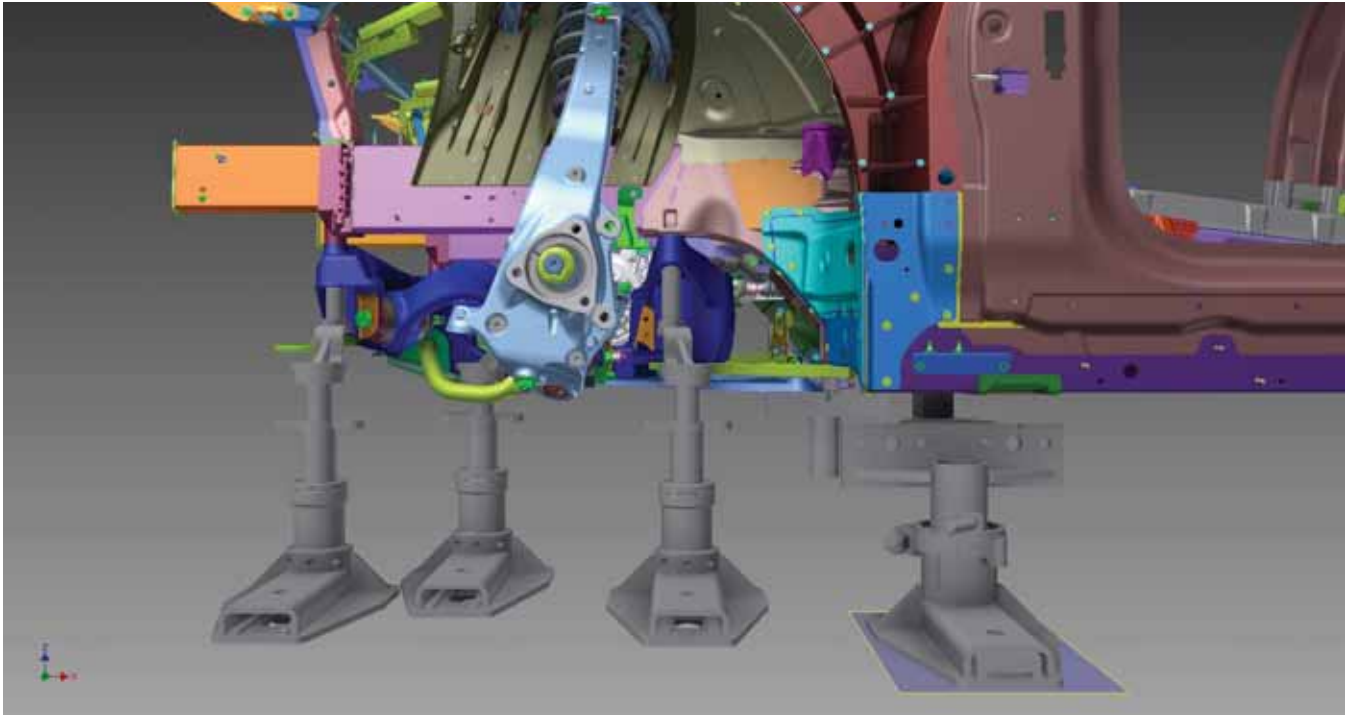

Left Front Parts On

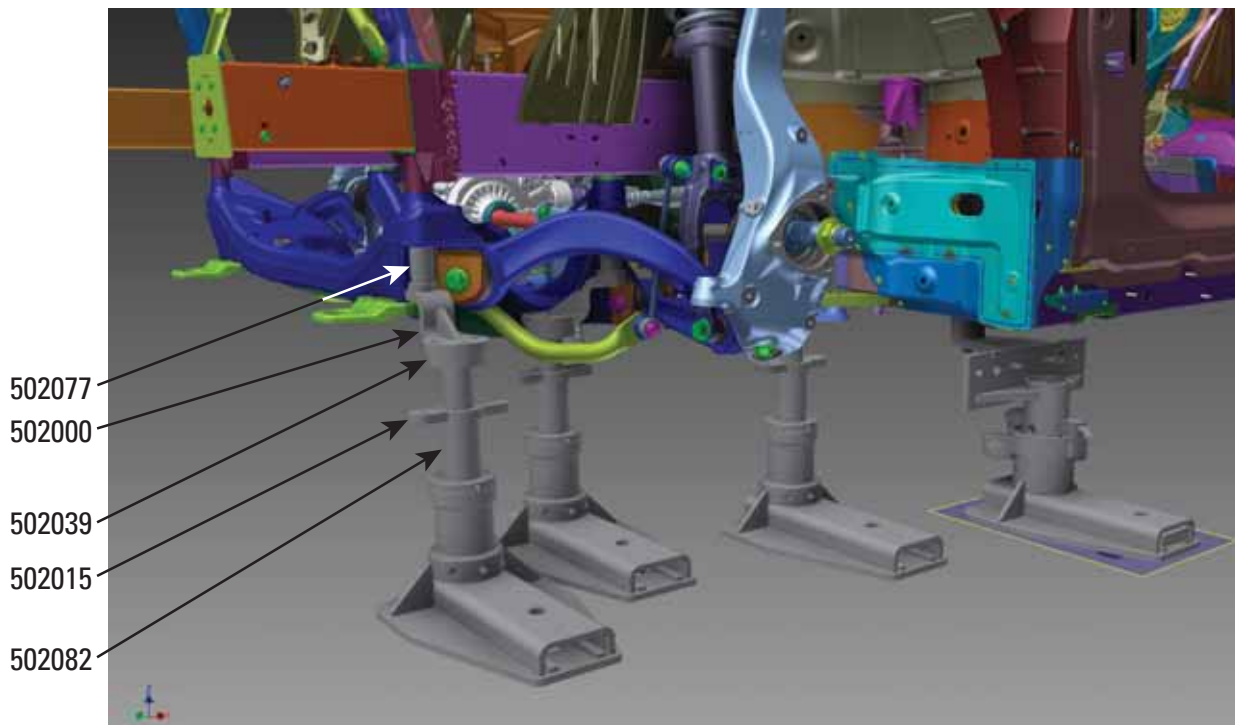

Rear Suspension Mounting Location

On the rear section additional holding can be located on the rear suspension bolt locations front or rear without main parts removal. With removal of the rear bumper cover and absorber, holding can be located at the end of the rail.

Left Rear Parts On

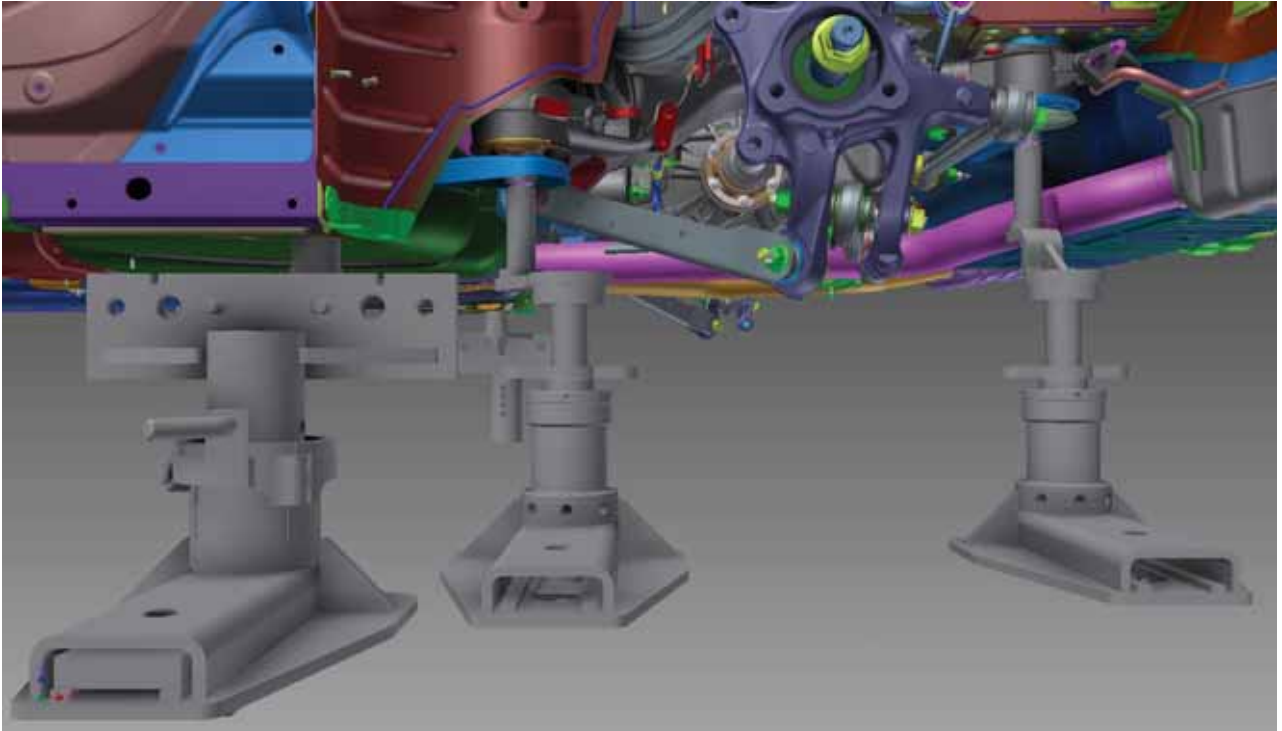

Left Rear Parts On

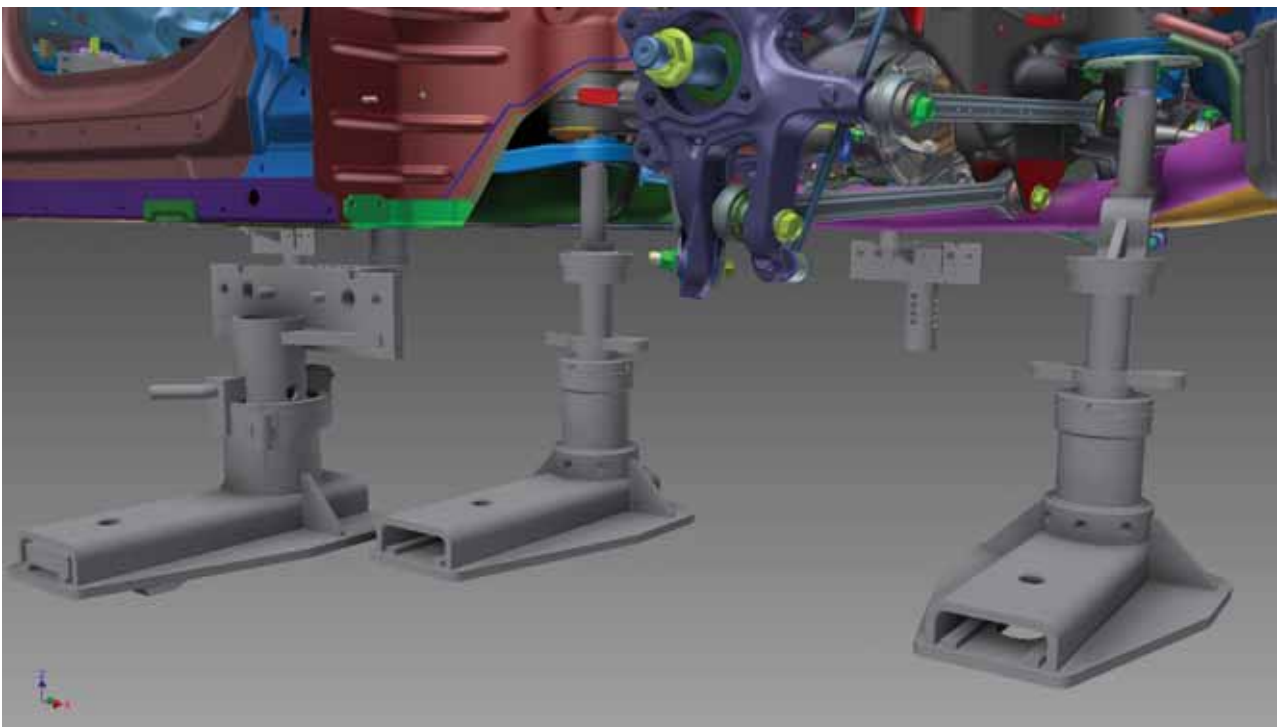

Left Rear Parts On

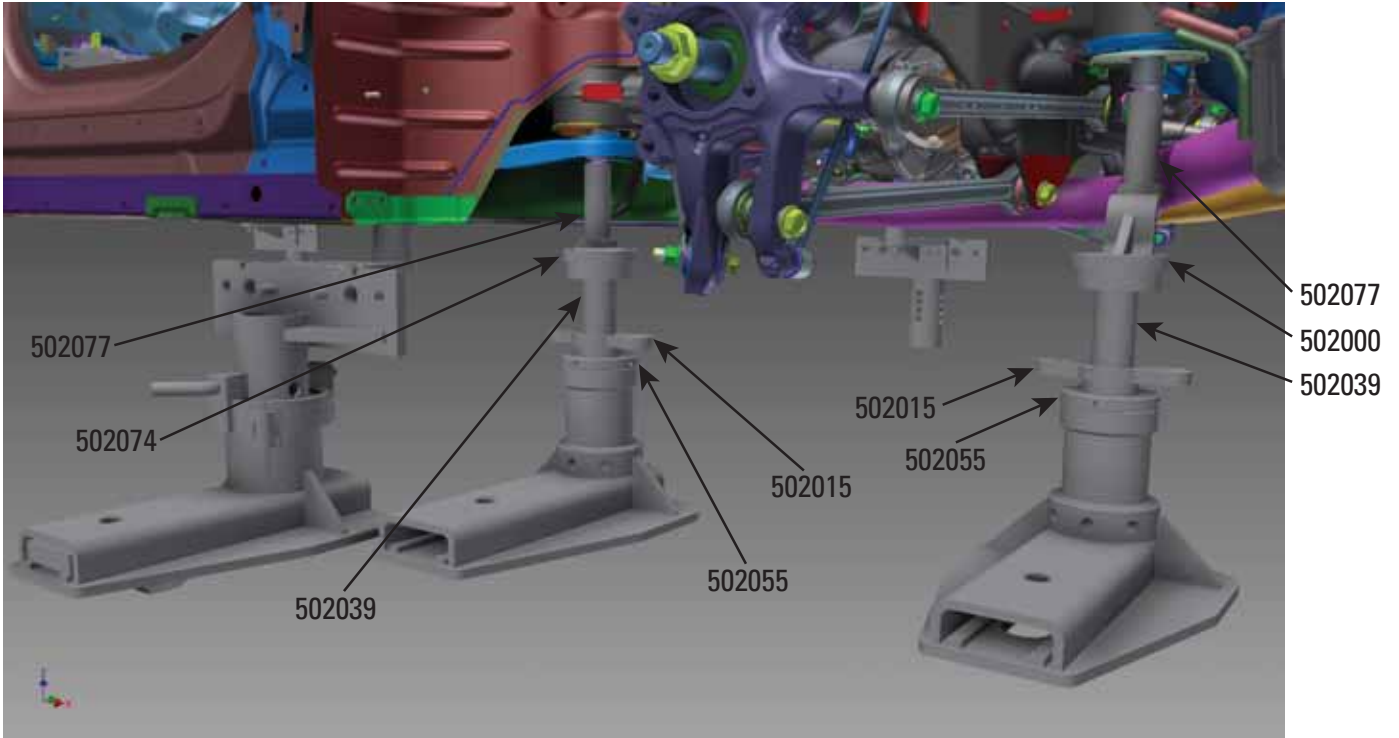

CT6 Parts-Off

Left Front Parts Off

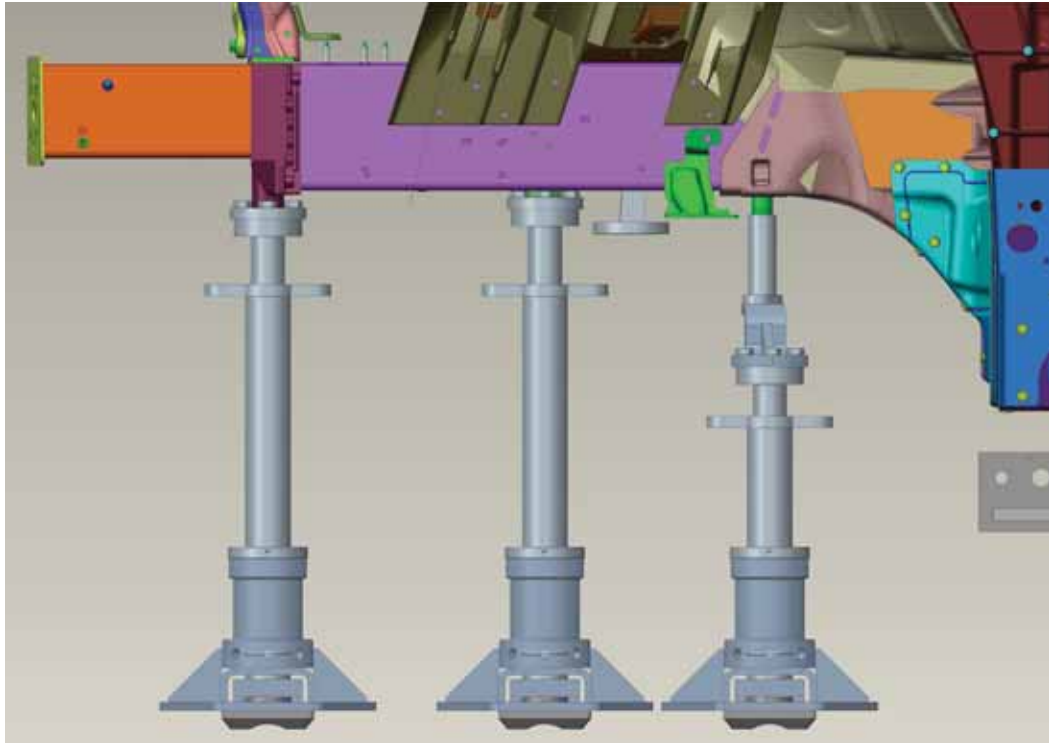

Left Front Parts Off

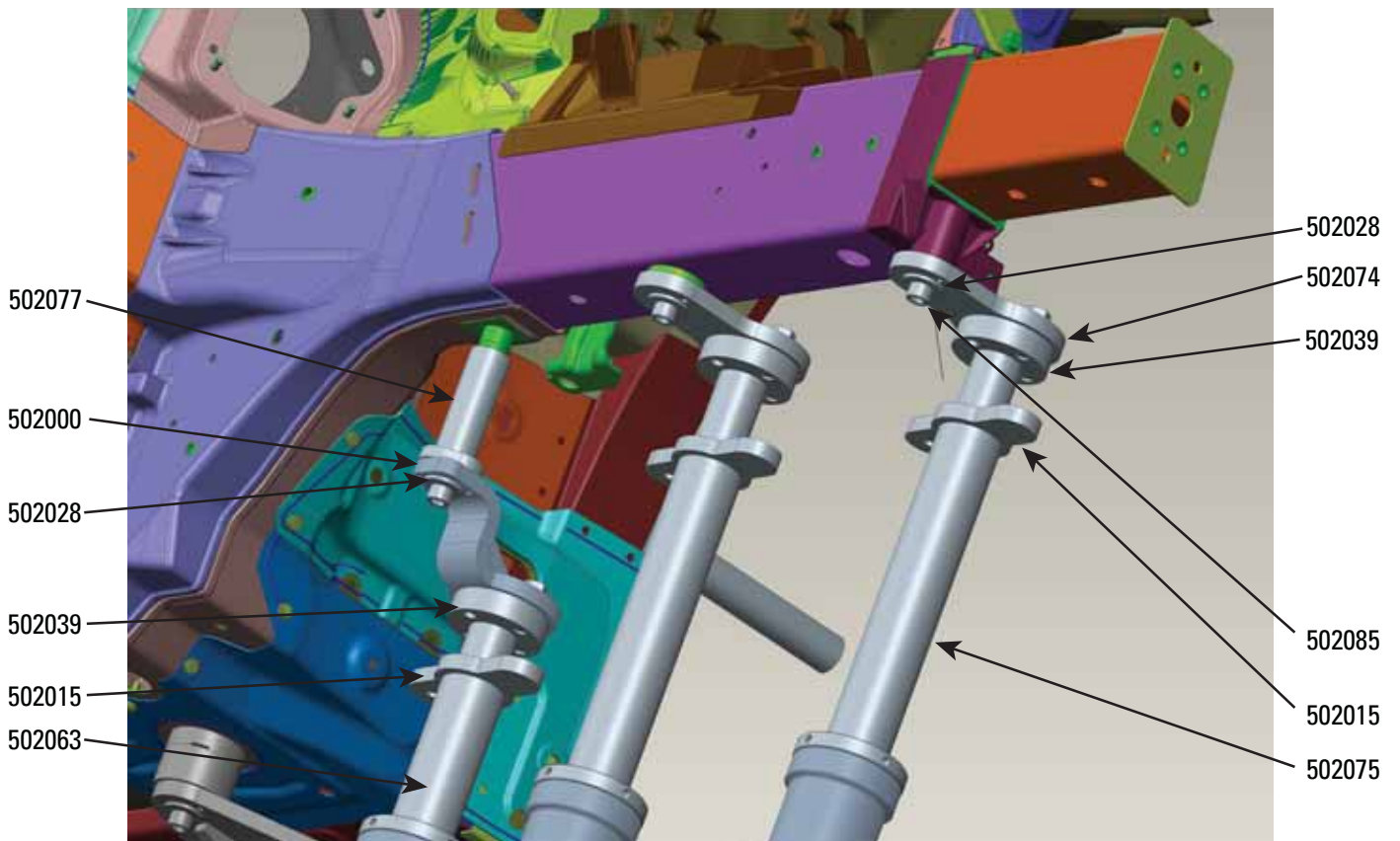

Left Rear Parts Off

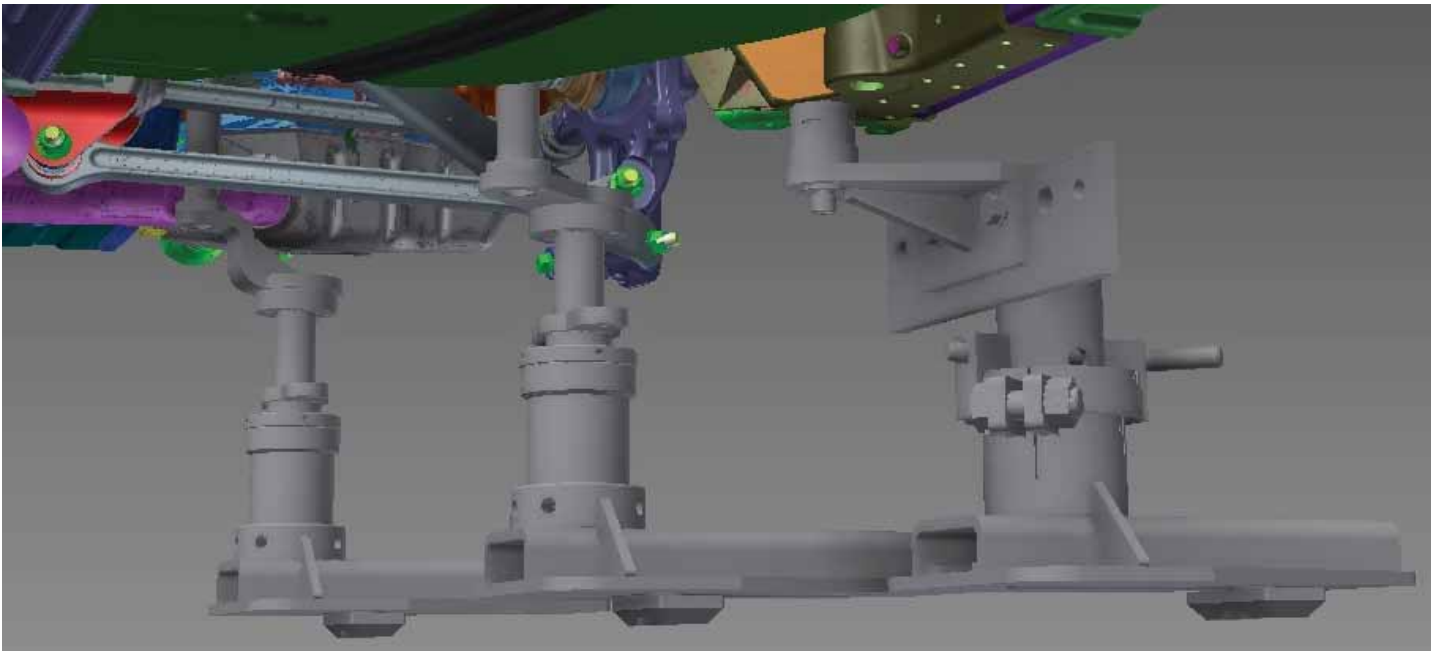
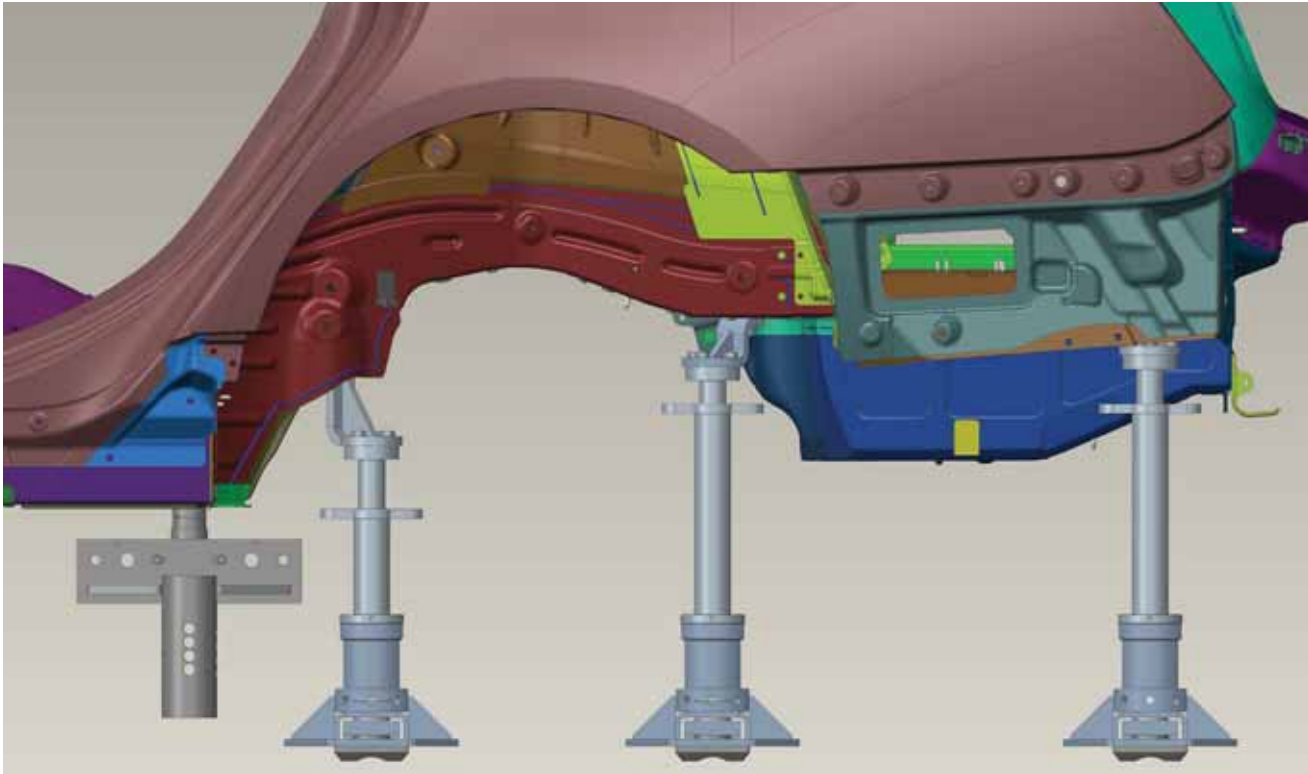

Bottom View Left Rear Parts Off



Bottom View Left Rear Parts Off

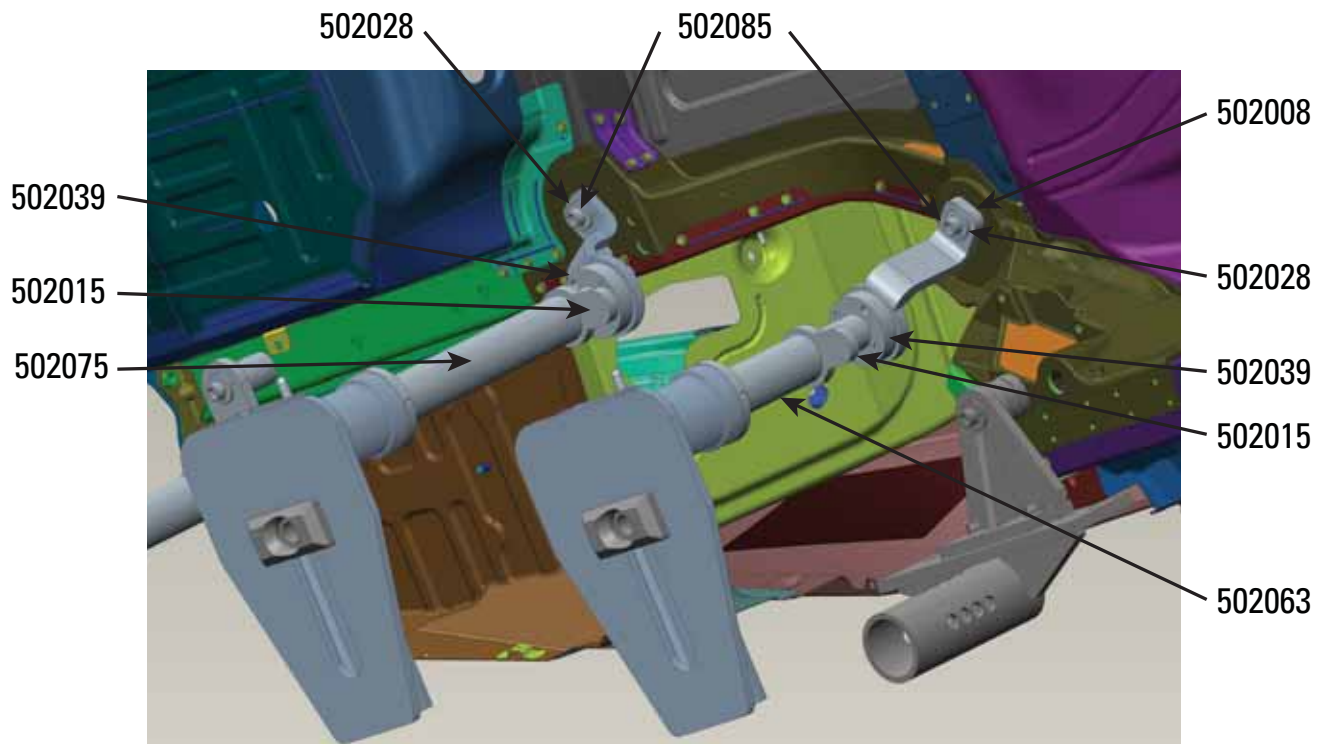

Left Side Front Strut Parts Off

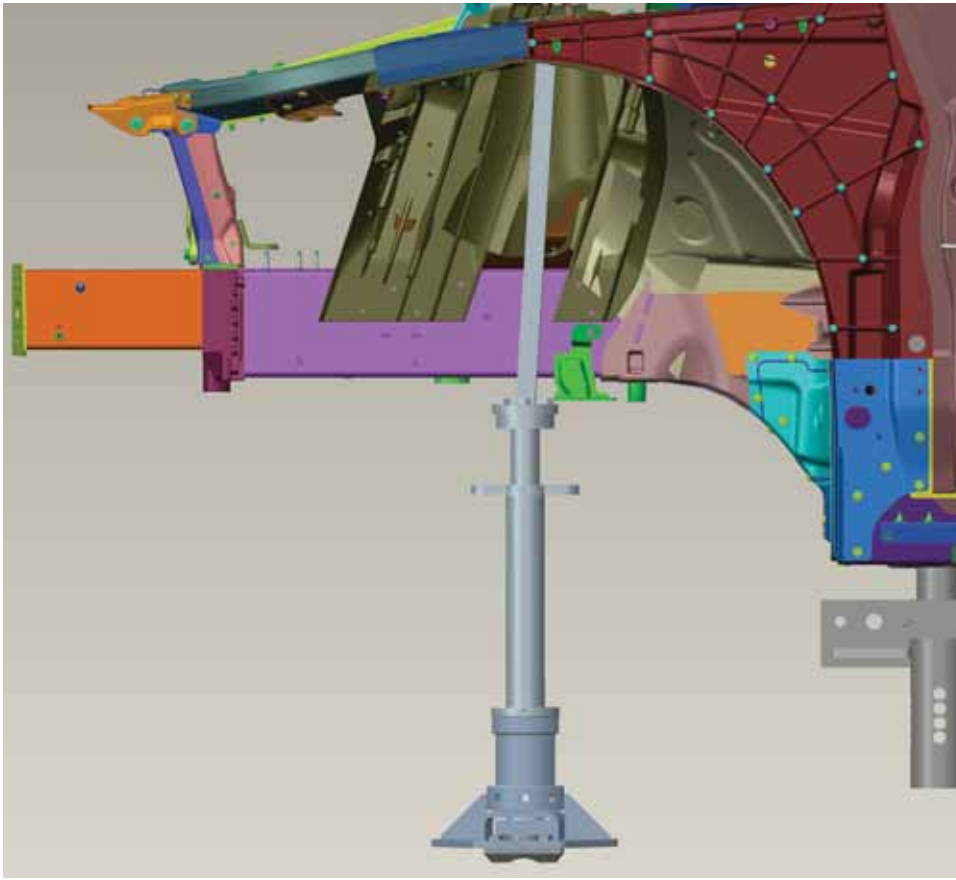

Left Side Front Strut Parts Off

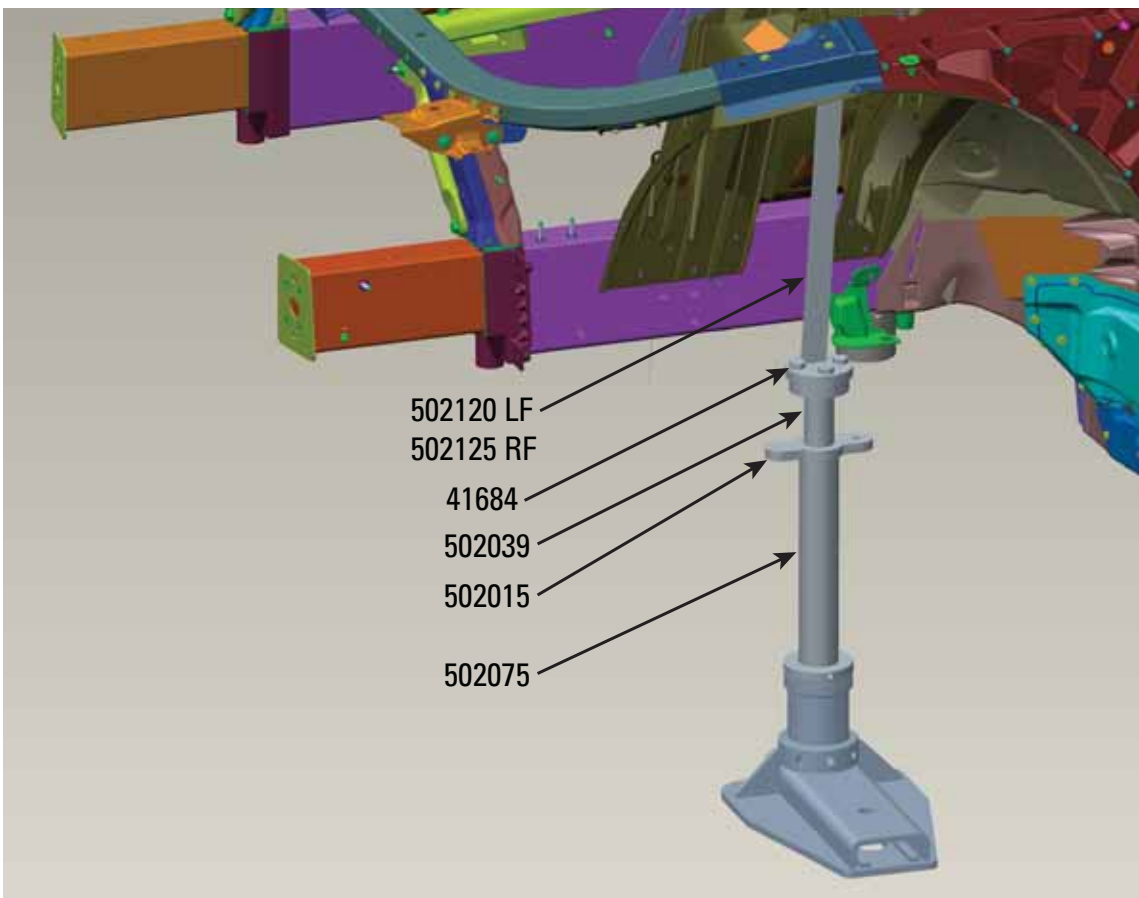

Left Side Front Strut Bottom View Parts Off

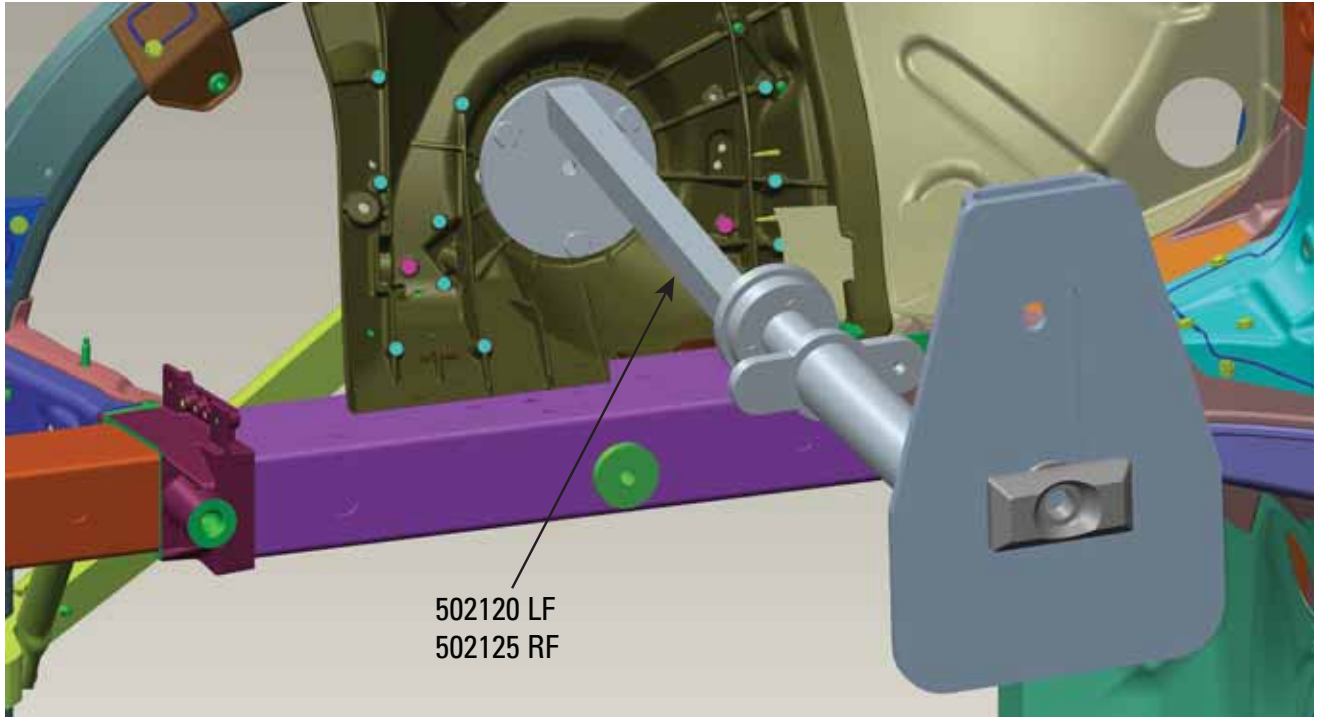

Left Side Rear Strut Parts Off

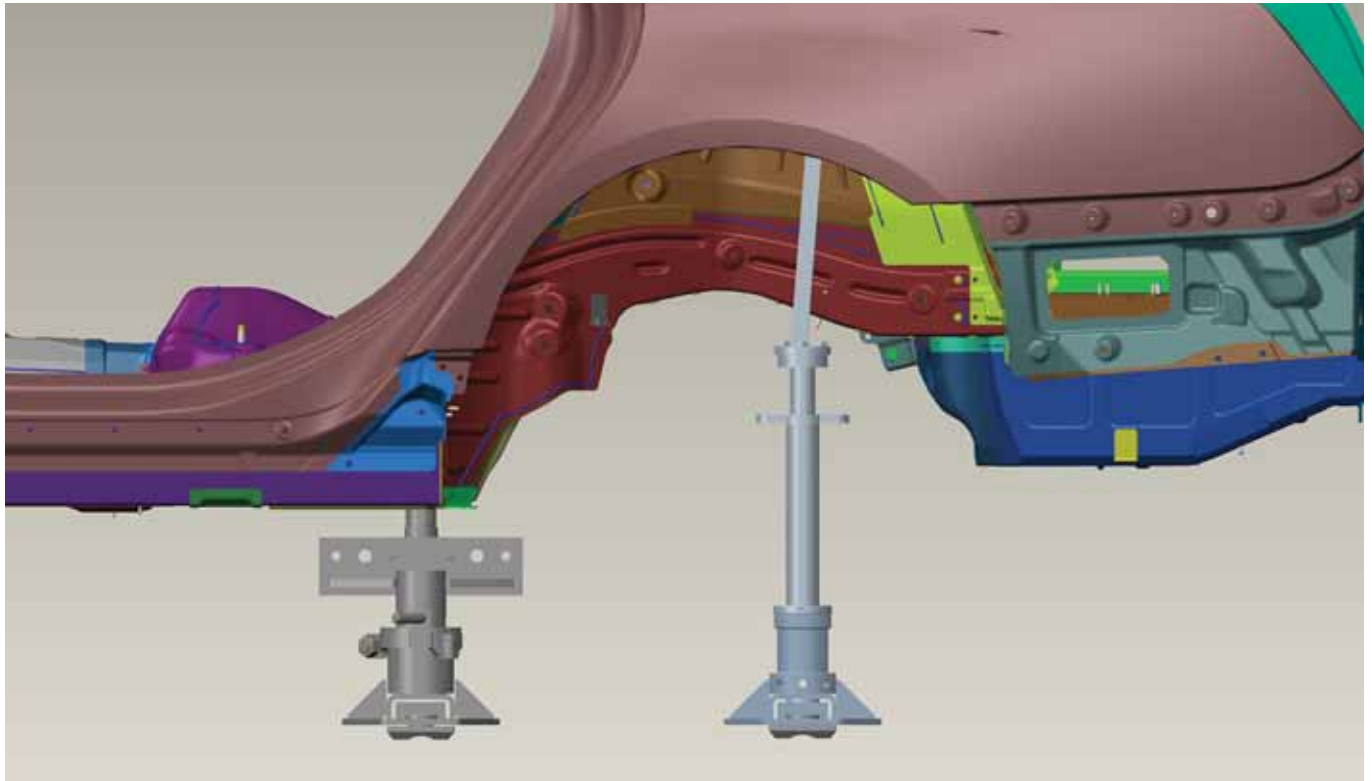

Left Side Rear Strut Parts Off

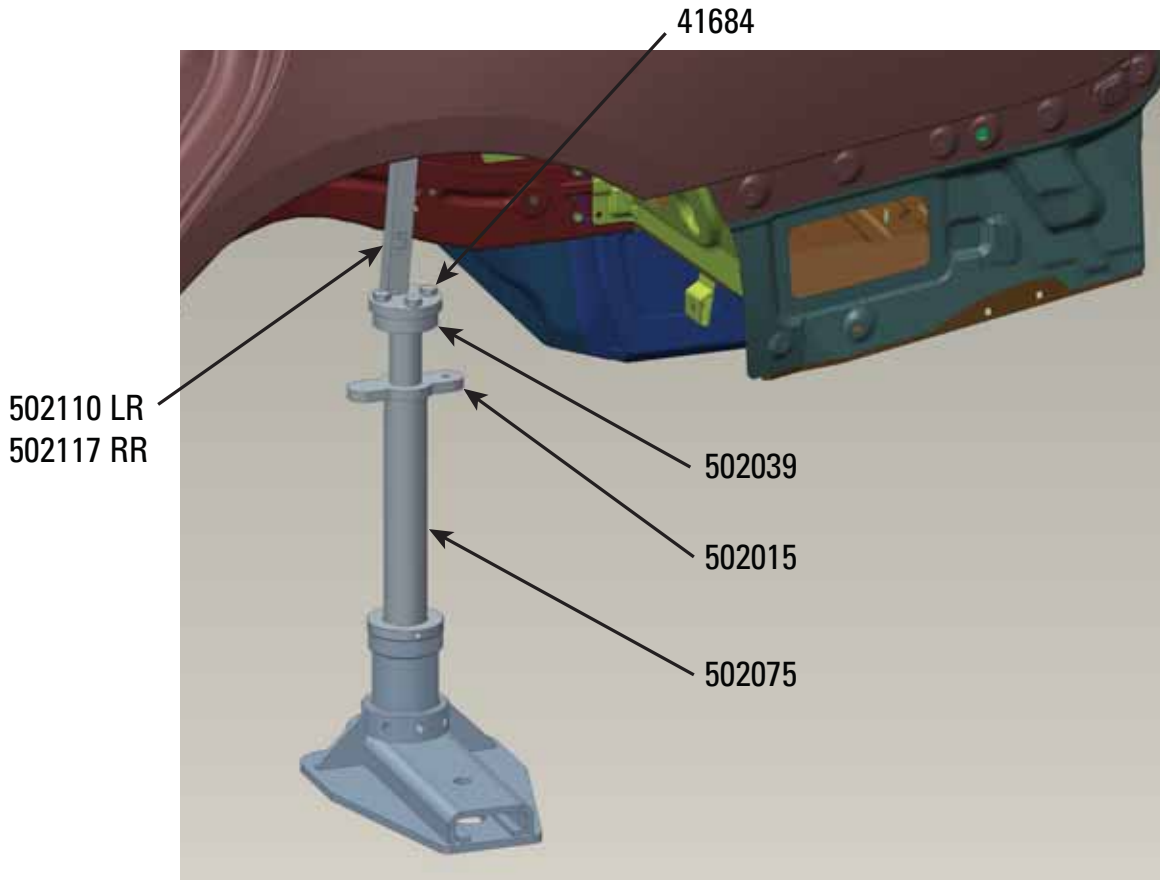

Left Side Rear Strut Bottom View Parts Off



Right Side A Pillar

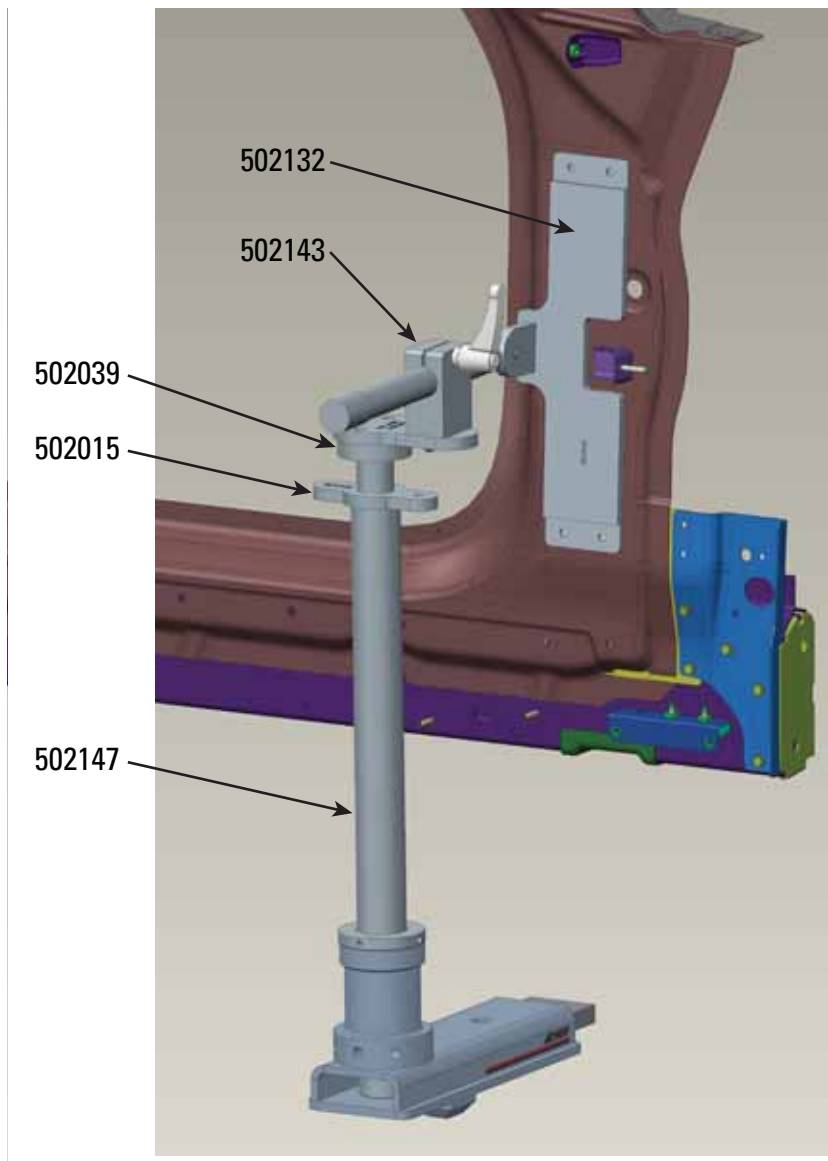

Right Side B Pillar

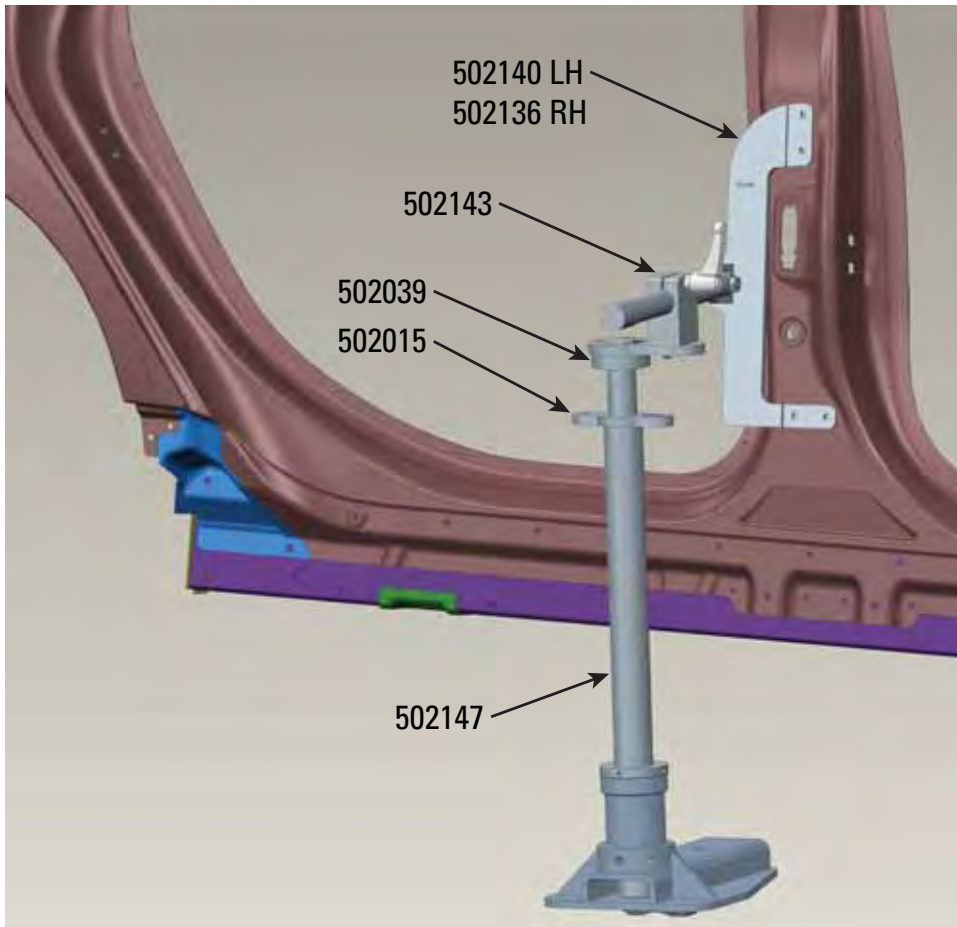

CT6 Measuring in Genesis

The CT6 vehicle specification in the Chief Genesis application was generated directly from GM CAD data files. The specification represents the vehicle in a level position, when supported at least 8 points (2 front, 4 center, and 2 rear locations).

The CT6 can be measured for inspection purposes when supported only in the 4 center section holding points. In this case, with a fully assembled vehicle, the front section measuring points may show 3-5mm of sag versus the level vehicle spec. Less sag will appear in the rear section.

To level out the sag from a fully assembled vehicle, front and rear fixtures can be built up to the holding points. The fixtures can then be raised using the turnbuckle adjustment detailed in the “Planning and Setup” section at the front of this manual, until the front and rear measuring points are level to the specification.

Always refer to OEM repair procedures for proper repair guidelines.

Measuring from Fixtures

For underbody measurement points, targets may be hung from (502085) M12 x 45mm bolt as shown.

HANG TARGET USING
(780104) 16mm MAGNETIC
BOLT ATTACHMENT

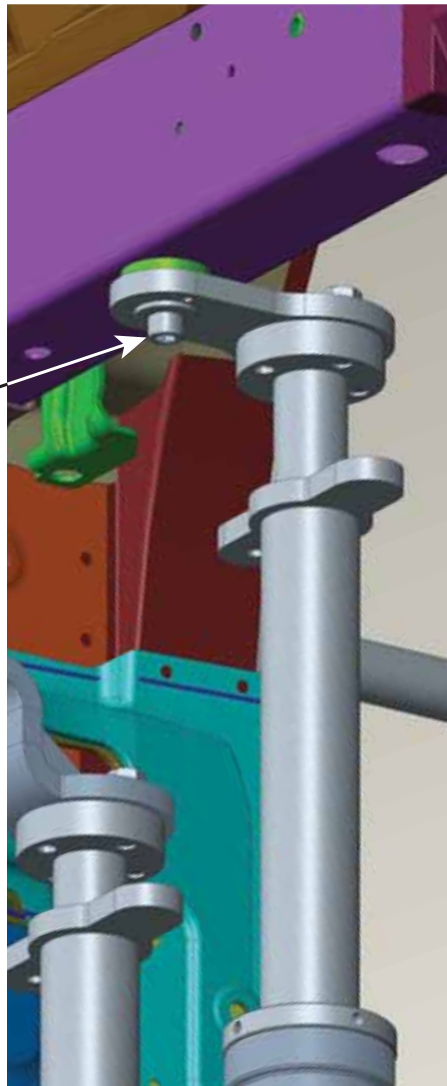

Fixture attachment offsets can be selected from illustrations shown earlier in this manual starting on page 5. After identifying and selecting the required fixture attachment used to hold and position the replacement part, the Chief electronic measuring system contains matching tools that can be selected from the attachment menus. Scroll through menus and select tools to match the fixture applied to vehicle. See example below.

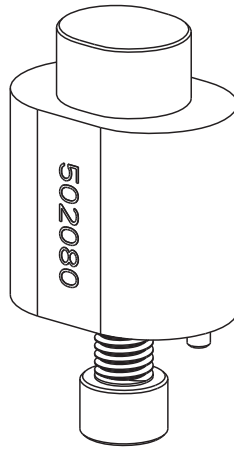

Note: When measuring from the oval hole fixture, measurements will appear 2.0mm towards the end of the vehicle compared to the vehicle spec location.

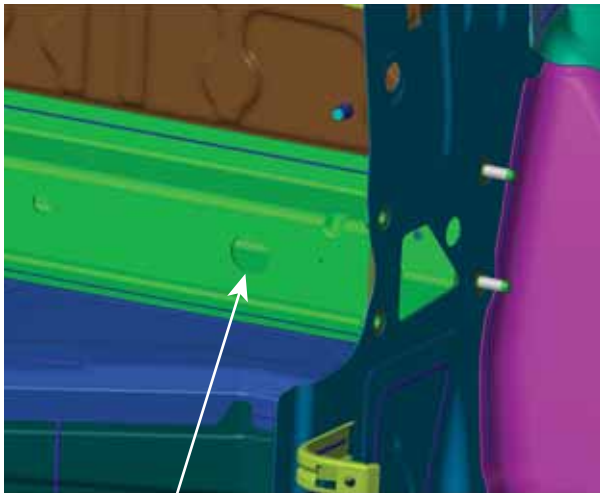

OVAL FIXTURE
LOCATION

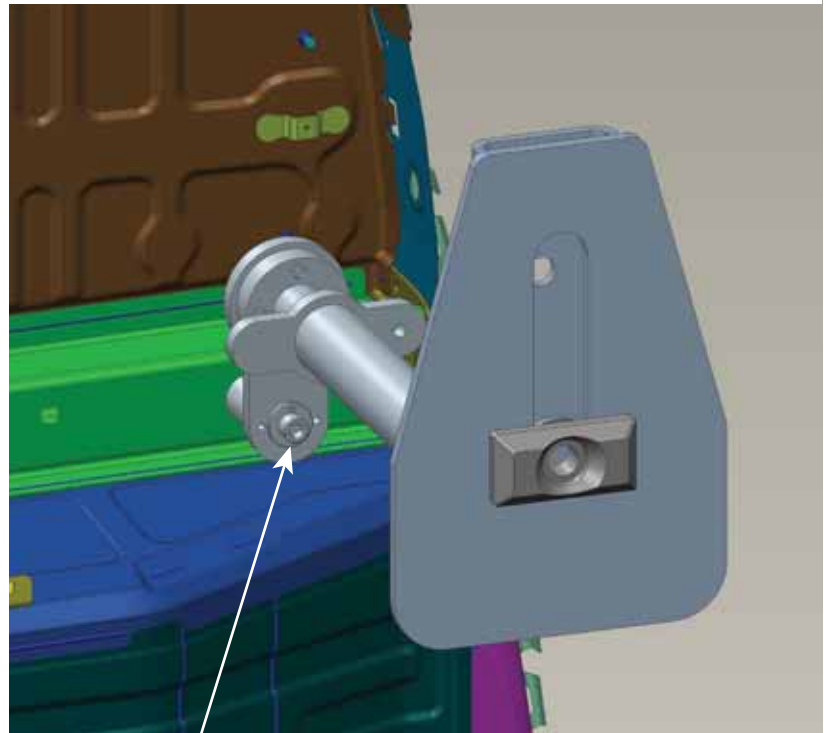

OVAL FIXTURE
BOLT HEAD

Note: Fixture offsets cannot be added to end-of-rail measurements. When measuring on the end of a rail, always place fixture on an opposing hole.

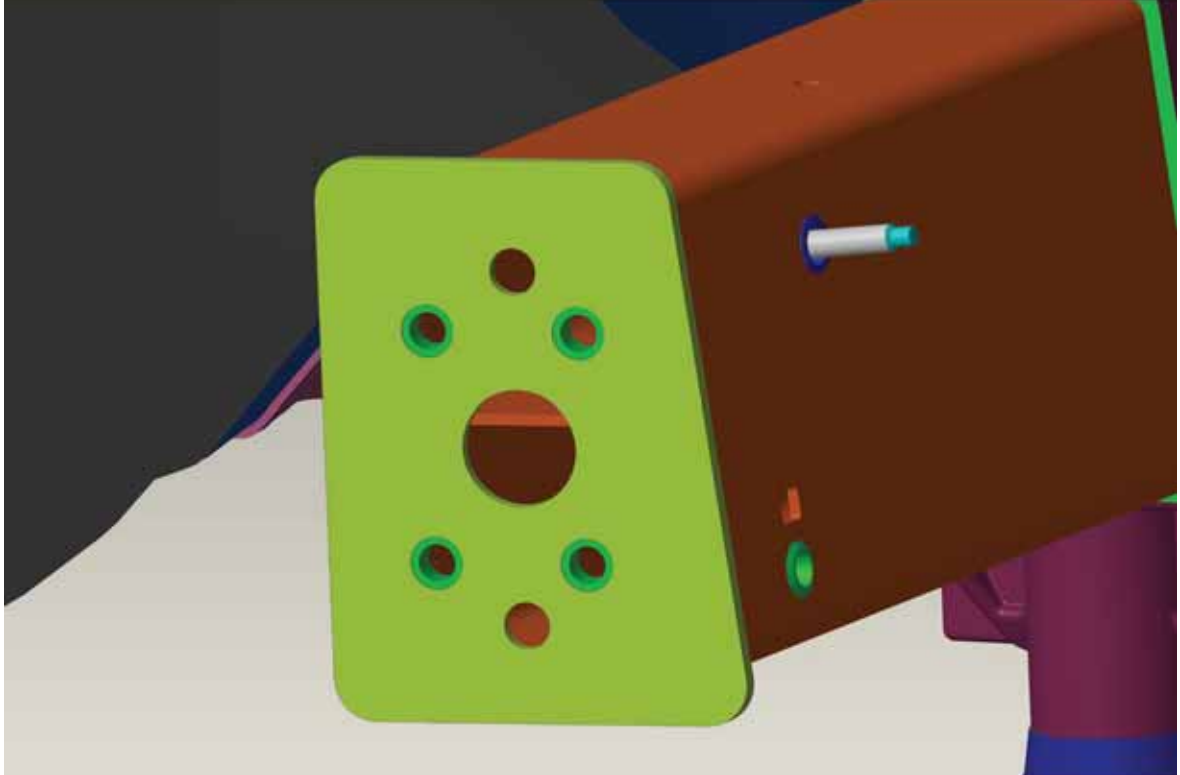



Chief Automotive Technologies
996 Industrial Drive
Madison, IN 47250
Phone: 800-445-9262
Fax: 866-275-0173



www.chiefautomotive.com

Chief reserves the right to alter product specifications
and/or package components without notice.