

BMW Clamping Adapters

Without Sidejack Lifting Holes



USERS MANUAL

Part No. 519640



Introduction

Specially designed clamping adapters can be used with the Universal Measuring System's (UMS) pinchweld stands or with adapter tubes mounted in Universal Anchoring System (UAS) bases. The clamping adapters allow positive anchoring of BMW vehicles without side jack lifting holes.

Each set of clamping adapters allows attachment of one clamp to a horizontal pinchweld flange and the bolting of the stand to a reinforced oval hole on the bottom of the vehicle's rocker panel.

Prior to using this anchoring equipment, read the following note which relates to usage of UMS pinchweld stands and UAS bases. Then refer to the appropriate instructions for the BMW model to be anchored.

NOTE:

1. If using UMS pinchweld stands, first position mounting brackets on mainframe below four corners of vehicle's center section. After attaching BMW adapters to stands, insert stands into the brackets at their respective mounting locations. DO NOT secure stands to brackets nor brackets to mainframe until all four anchoring assemblies are firmly secured to rocker panel and its pinchweld.
2. If using UAS bases, attach BMW adapters to UMS adapter tubes and insert tubes in bases. Then position anchoring bases at respective mounting locations at corners of vehicle's center section. Loosely attach bases to mainframe using appropriate bolts and fastener plates, but DO NOT secure adapter tubes within the bases. Securing bases to mainframe prevents them from kicking out when installing attachments on opposite side of vehicle.

CHIEF'S LIMITED ONE-YEAR WARRANTY & LIABILITY

Chief Automotive Technologies, Inc. warrants for one year from date of installation and/or purchase any of its products which do not perform satisfactorily due to defect caused by faulty material or workmanship. Chief's obligation under this warranty is limited to the repair or replacement of products which are defective and which have not been misused, carelessly handled, or defaced by repair or repairs made or attempted by others.

CHIEF AUTOMOTIVE TECHNOLOGIES, INC. DOES NOT ASSUME RESPONSIBILITY FOR ANY DEATH, INJURY OR PROPERTY DAMAGE RESULTING FROM THE OPERATOR'S NEGLIGENCE OR MISUSE OF THIS PRODUCT OR ITS ATTACHMENTS. CHIEF MAKES NO WRITTEN, EXPRESS OR IMPLIED WARRANTY WHATSOEVER OF MERCHANTABILITY OR FITNESS FOR A PARTICULAR PURPOSE OR OTHERWISE REGARDING THE EQUIPMENT OR ANY PART OF THE PRODUCT OTHER THAN THE LIMITED ONE-YEAR WARRANTY STATED ABOVE.

BMW 3 Series (Without Side Jack Lifting Holes)

NOTE: Clamping adapters mount to either the Universal Measuring System Pinchweld Stands (shown here) or to adapter tubes which fit in Universal Anchoring System Bases.

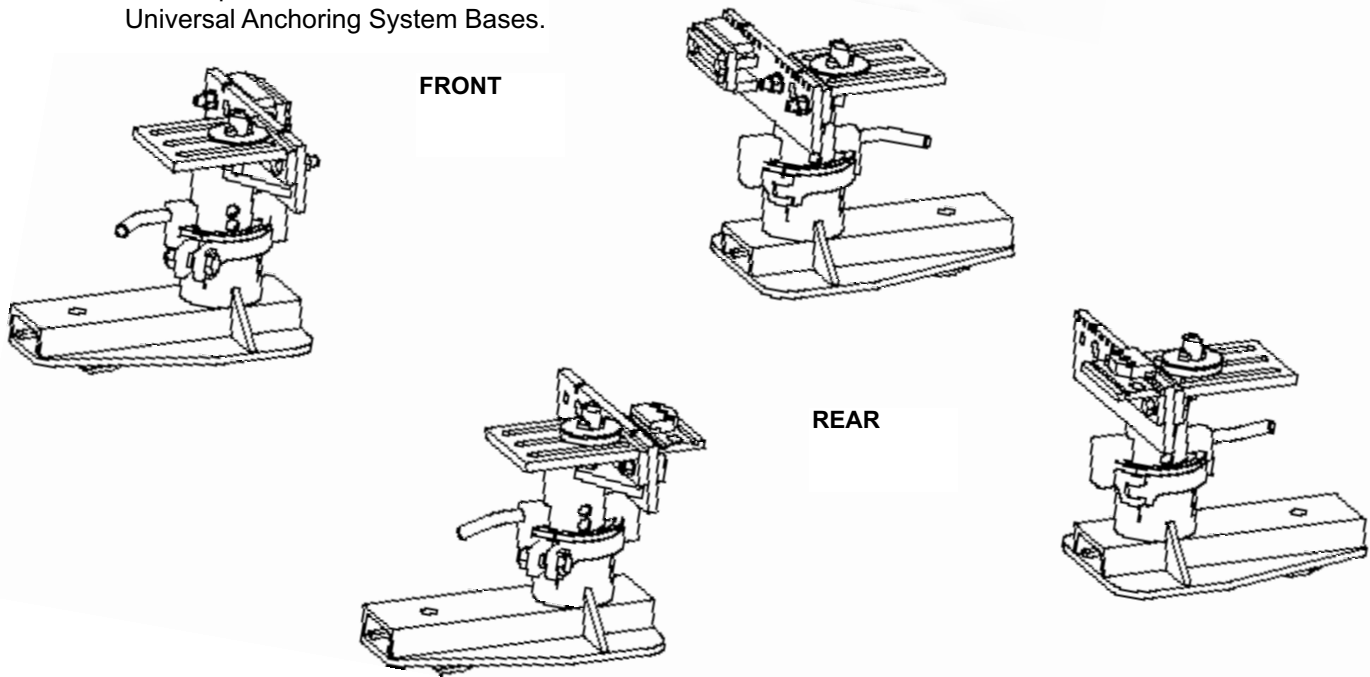
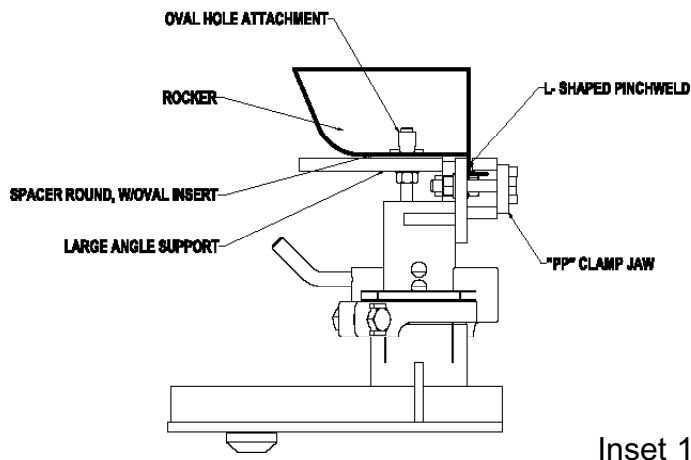

Figure 1

Front View Of Front Right Stand



Inset 1

Rear View Of Rear Left Stand

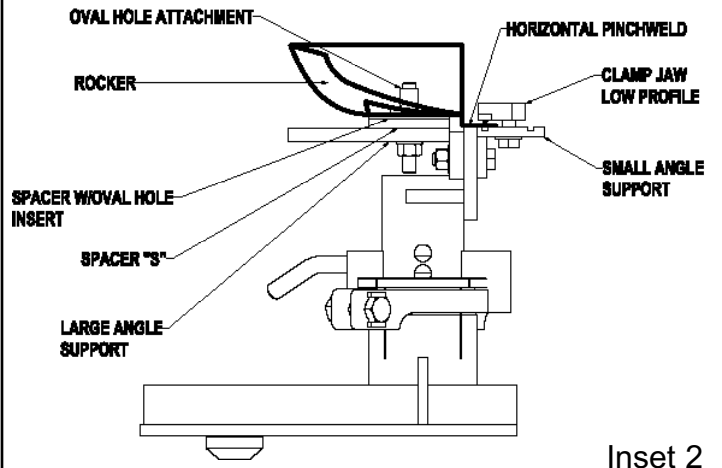

Inset 2

BMW 3 Series (Without Side Jack Lifting Holes) Clamping Instructions

(Refer to illustrations on page 2.)

1. Remove oval hole plugs and plastic shields under vehicle's rocker panels. Also remove fuel tank, hoses, lines, wires, brackets and undercoating that interferes with installation of anchoring equipment.
2. Remove clamp jaws from anchoring stand.
3. Attach large angle support to rear of each front anchoring stand and to rear of each rear anchoring stand. (See Figure 1.)
NOTE: Attach supports to outside surface of anchoring stand's vertical plate as shown.
4. Attach small angle support to rear of each rear anchoring stand. (See Figure 1.)
NOTE: Attach supports to inside surface of anchoring stand's vertical plate as shown.
5. Position oval hole attachment and spacer with oval hole insert on top of each large angle support mounted to front stands. (See Figure 1 - Inset 1.) Then position oval hole attachment, spacer with oval hole insert, and spacer 'S' on large angle supports mounted to rear stands. (See Figure 1 - Inset 2.) Threaded portion of oval hole attachments must project downward through spacer(s) and through center slot of each large angle support.
6. Use appropriate lifting device to elevate one side of vehicle and position front anchoring stands so that front edge of vertical plate is 85mm rearward of rocker panel at wheel opening. Inside surface of stand's vertical plate must be flush with vertical surface of L-shaped pinch-weld flange. (See Figure 1 - Inset 1.) Also align oval hole attachment with oval hole in bottom of rocker panel.
CAUTION: Grip threaded portion of oval hole attachment when aligning attachment with oval hole in  rocker panel. DO NOT place hands between rocker panel and anchoring components.
7. Lower vehicle so that oval hole attachment engages oval hole in bottom of rocker panel. Then grip threaded end of oval hole attachment to push attachment upward. Rotate attachment 90 degrees so that it straddles inside of oval hole in rocker panel and use

1/2 inch nut and washer to secure anchoring stand to rocker panel.
NOTE: To verify a secure hold, slightly raise vehicle. If stand also raises, it is secure. If it doesn't, lower vehicle and repeat Step 7.
8. Secure PP clamp jaw to inside surface of vertical plate (see Figure 1 - Inset 1) engaging it with L-shaped pinch-weld flange in the process.
NOTE: Horizontal portion of L-shaped pinchweld may need restraightening following the repair.
9. Repeat Steps 6-8 on opposite side of vehicle.
10. To install rear anchoring stand, elevate side of vehicle and position rear edge of stand's vertical plate 300 mm forward of front edge of rear wheel opening. Top edge of vertical plate must be directly below rocker reinforcement and horizontal pinchweld. Also align oval hole attachment with oval hole in bottom of rocker panel.
CAUTION: Grip threaded portion of oval hole attachment when aligning attachment with oval hole in  rocker panel. DO NOT place hands between rocker panel and anchoring components.
11. Lower vehicle so that oval hole attachment engages oval hole in bottom of rocker panel. Then use threaded end of oval hole attachment to push attachment upward. Rotate attachment 90 degrees so that it straddles inside of hole in rocker panel and use 1/2 inch nut and washer to secure anchoring stand to rocker panel.
NOTE: To verify a secure hold, slightly raise vehicle. If stand also raises, it is secure. If it doesn't, lower vehicle and repeat Step 11.
12. Secure clamp jaw - low profile (or half clamp) to top surface of small angle support (see Figure 1 - Inset 2) engaging it with horizontal pinchweld in the process.
13. Repeat Steps 6-12 on opposite side of vehicle.

BMW 5 Series (2001-2003)

NOTE: Clamping adapters mount to either the Universal Measuring System Pinchweld Stands (shown here) or to adapter tubes which fit in Universal Anchoring system Bases.

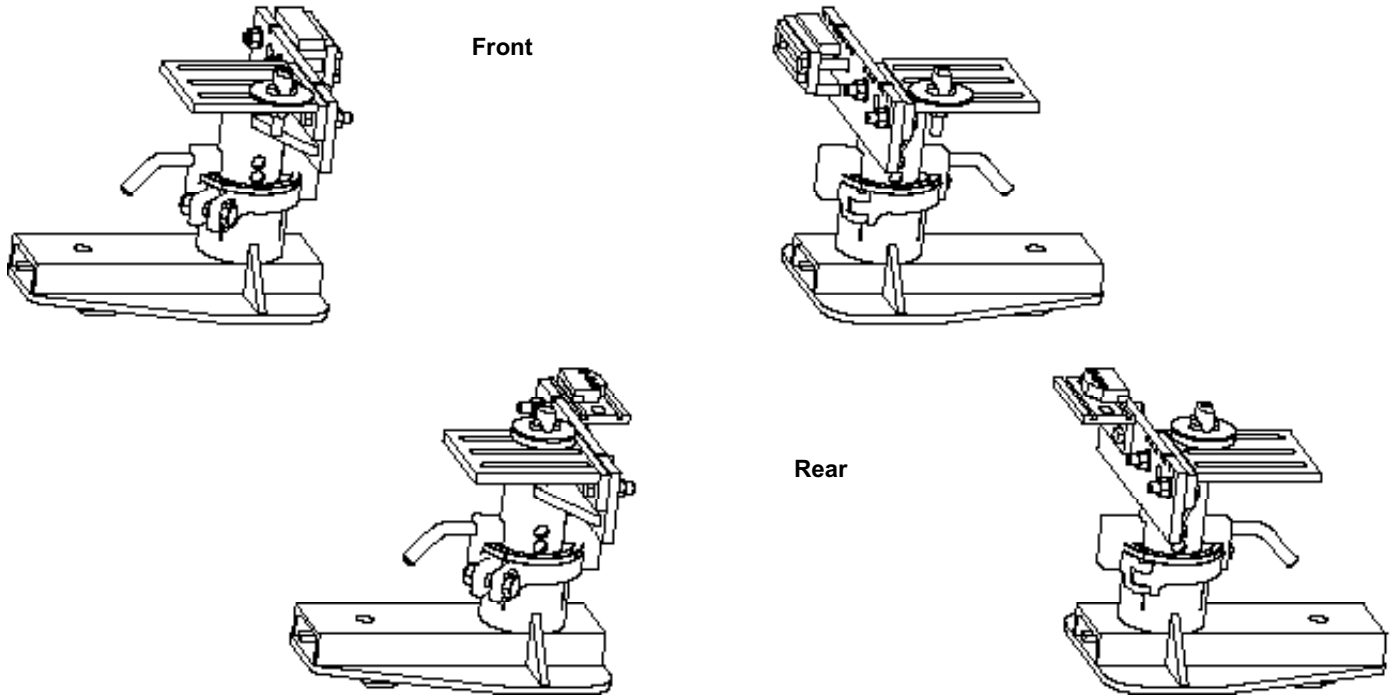
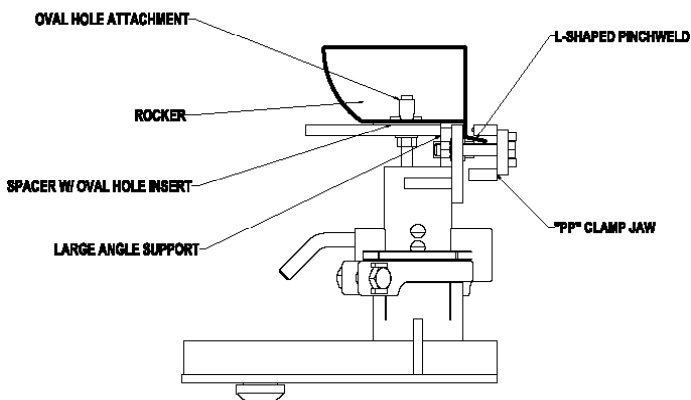

Figure 2

Front View Of Front Right Stand



Inset 1

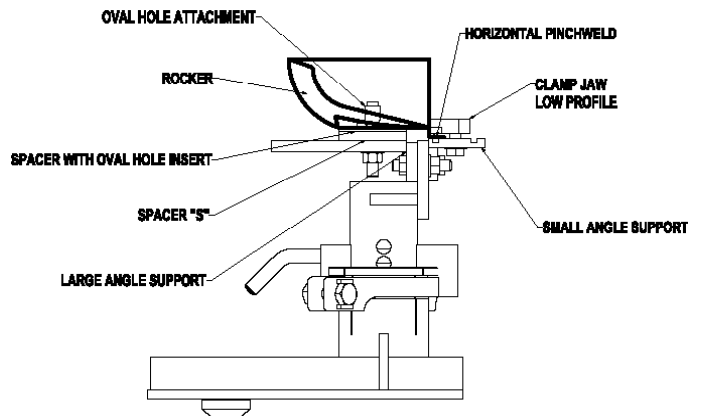

Rear View Of Rear Left Stand



Inset 2

BMW 5 Series Clamping Instructions (2001-2003)

(Refer to illustrations on page 4.)

1. Remove oval hole plugs and plastic shields under vehicle's rocker panels. Also remove fuel tank, hoses, lines, wires, brackets and undercoating if they will interfere with installation of anchoring equipment.
2. Remove clamp jaws from anchoring stand.
3. Attach a large angle support to rear of each anchoring stand. (See Figure 2.)
NOTE: Attach supports to outside surface of anchoring stand's vertical plate as shown.
4. Attach a small angle support to front of each rear anchoring stand. (See Figure 2.)
NOTE: Attach supports to inside surface of anchoring stand's vertical plate as shown.
5. Position oval hole attachment and spacer with oval hole insert on top of each large angle support mounted to front stands. (See Figure 2 - Inset 1.) Then position oval hole attachment, spacer with oval hole insert, and spacer 'S' on large angle supports mounted to rear stands. (See Figure 2 - Inset 2.) Threaded portion of oval hole attachments must project downward through spacer(s) and through rear slot on front stands and through front slot on rear stands.
6. Use appropriate lifting device to elevate one side of vehicle and position front anchoring stands so that front edge of vertical plate is 90mm rearward of rear edge of rocker panel at wheel opening. Inside surface of stand's vertical plate must be flush with vertical surface of L-shaped pinchweld flange. (See Figure 2 - Inset 2.) Also align oval hole attachment with oval hole in bottom of rocker panel.
CAUTION: Grip threaded portion of oval hole attachment when aligning attachment with oval hole in rocker panel. DO NOT place hands between rocker panel and anchoring components.

7. Lower vehicle so that oval hole attachment engages oval hole in bottom of rocker panel. Then grip threaded end of oval hole attachment to push attachment upward. Rotate attachment 90 degrees so that it straddles inside of oval hole in rocker panel and use 1/2 inch nut and washer to secure the anchoring stand to the rocker panel.
NOTE: To verify a secure hold, slightly raise vehicle. If stand also raises, it is secure. If it doesn't, lower vehicle and repeat Step 7.
8. Secure PP clamp jaw to inside surface of vertical plate (see Figure 2 - Inset 1) engaging it with L-shaped pinchweld flange in the process.
NOTE: Horizontal portion of L-shaped pinchweld may need restraightening following the repair.
9. Repeat Steps 6 - 8 on opposite side of vehicle.
10. To install rear anchoring stand, elevate side of vehicle and align rear edge of stand's vertical plate with rear edge of rocker panel at wheel opening. Top edge of vertical plate must be directly below rocker reinforcement and horizontal pinchweld. Also align oval hole attachment with oval hole in bottom of rocker panel.
CAUTION: Grip threaded portion of oval hole attachment when aligning attachment with oval hole in rocker panel. DO NOT place hands between rocker panel anchoring components.

11. Lower vehicle so that oval hole attachment engages oval hole in bottom of rocker panel. Then use threaded end of oval hole attachment to push attachment upward. Rotate attachment 90 degrees so that it straddles inside of hole in rocker panel and use 1/2 inch nut and washer to secure anchoring stand to rocker panel.
NOTE: To verify a secure hold, slightly raise vehicle. If stand also raises, it is secure. If it doesn't, lower vehicle and repeat Step 11.
12. Secure clamp jaw to top surface of small angle support (see Figure 2 - Inset 2) engaging it with horizontal pinchweld in the process.
13. Repeat Steps 6 - 12 on opposite side of vehicle.

BMW 5 Series (2004-Current Year)

NOTE: Clamping adapters mount to either the Universal Measuring System basic stands (shown here) or to adapter tubes which fit in Universal Anchoring System Bases.

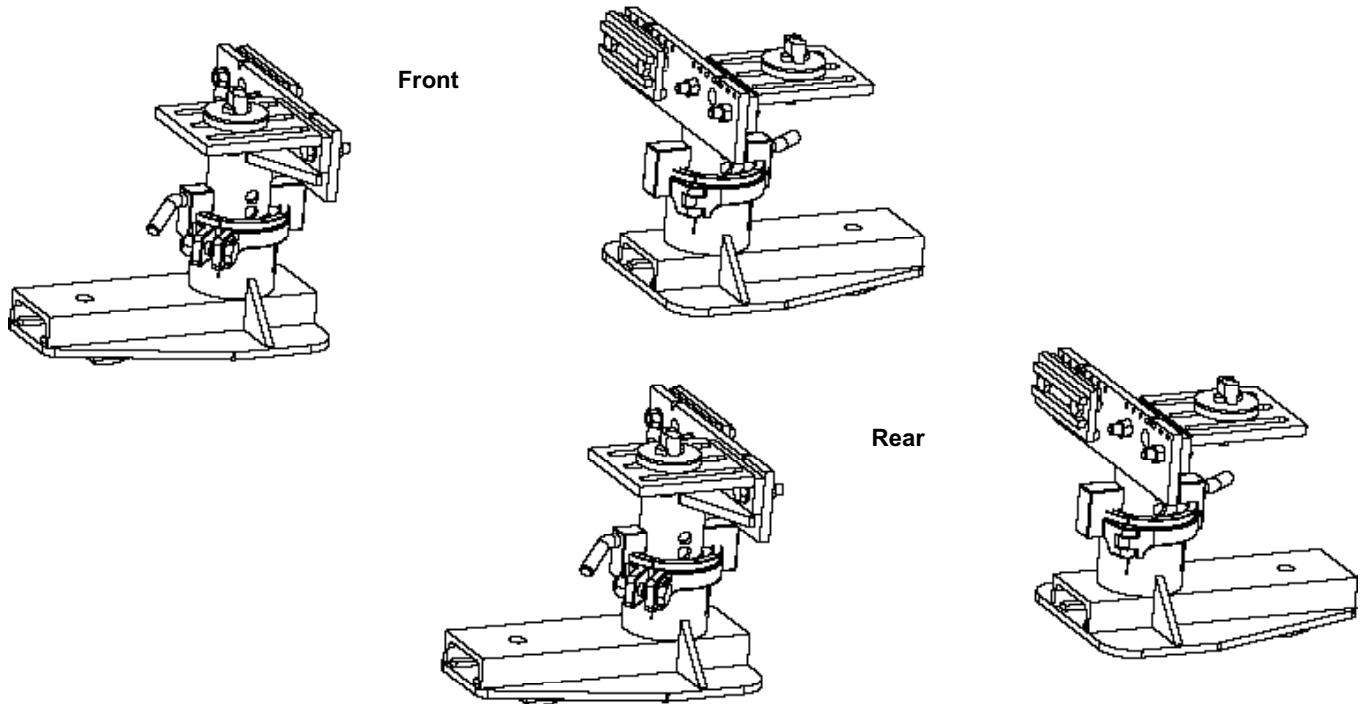
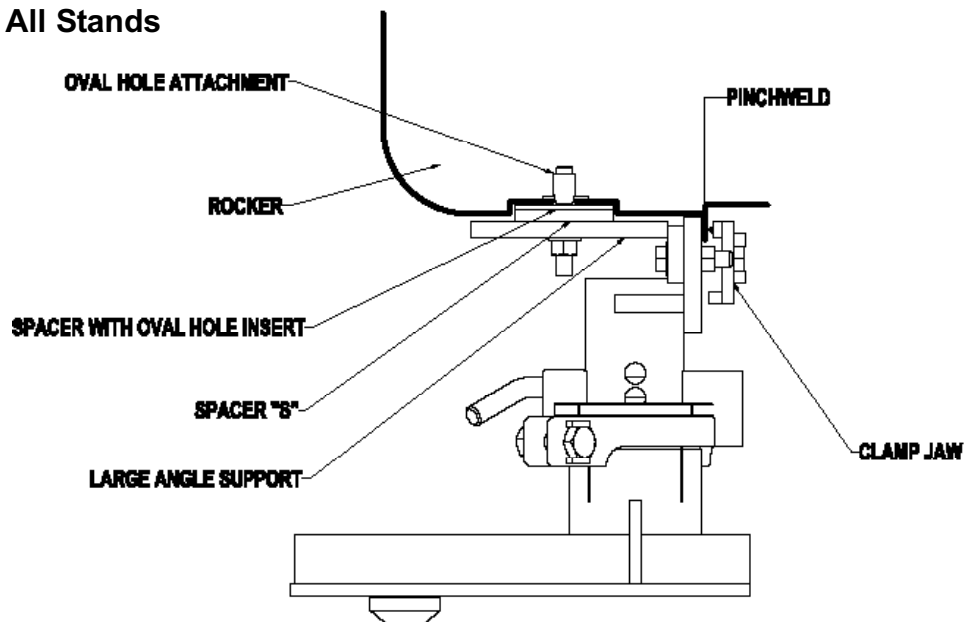

Figure 3

Front View Of All Stands



Inset 1

BMW 5 Series Clamping Instructions (2004-Current Year)

(Refer to illustrations on page 6.)

1. Remove oval hole plugs and plastic shields under vehicle's rocker panels.
2. Remove rear clamp jaws from anchoring stands.
3. Attach a large angle support to rear of each anchoring stand. (See Figure 3.)
NOTE: Attach supports to outside surface of anchoring stand's vertical plate as shown.
4. Position oval hole attachment, spacer with oval hole insert, and spacer 'S' on large angle supports mounted to stands. (See Figure 3 - Inset 1.) Threaded portion of oval hole attachments must project downward through spacer(s) and through center slot on all stands.
5. Use appropriate lifting device to elevate one side of vehicle and position inside surface of stand's vertical plate flush with vertical surface of pinchweld flange. (See Figure 3 - Inset 1.) Also align oval hole attachment with oval hole in bottom of rocker panel.
 **CAUTION:** Grip threaded portion of oval hole attachment when aligning attachment with oval hole in rocker panel. DO NOT place hands between rocker panel and anchoring components.
6. Lower vehicle so that oval hole attachment engages oval hole in bottom of rocker panel. Then grip threaded end of oval hole attachment to push attachment upward. Rotate attachment 90 degrees so that it straddles inside of oval hole in rocker panel and use 1/2 inch nut and washer to secure the anchoring stand to the rocker panel.
NOTE: To verify a secure hold, slightly raise vehicle. If stand also raises, it is secure. If it doesn't, lower vehicle and repeat Step 6.
7. Secure clamp jaw to inside surface of vertical plate (see Figure 3 - Inset 1) engaging it with pinchweld flange in the process.
8. Repeat Steps 5 - 7 for other positions on vehicle.

BMW Z3 Roadster And Coupe

NOTE: Clamping adapters mount to either the Universal Measuring System basic stands (shown here) or to adapter tubes which fit in Universal Anchoring System Bases.

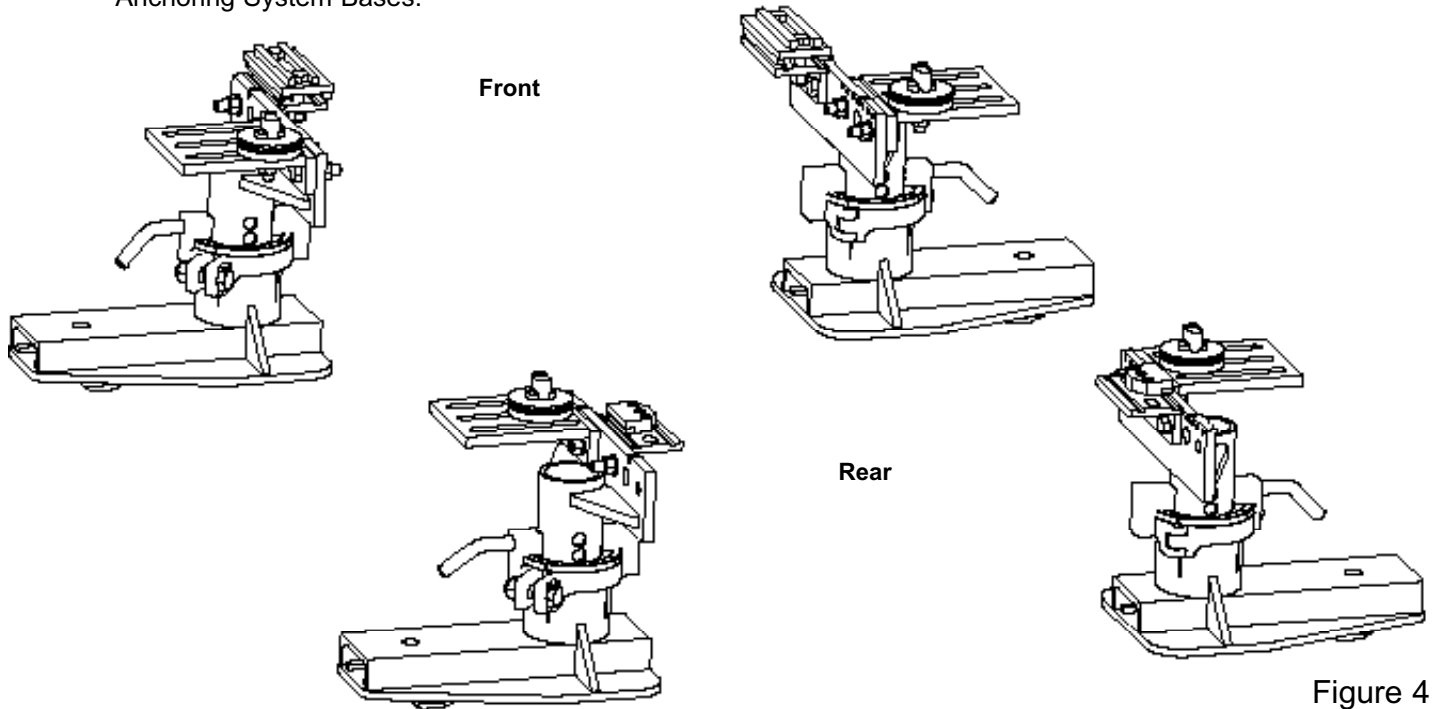
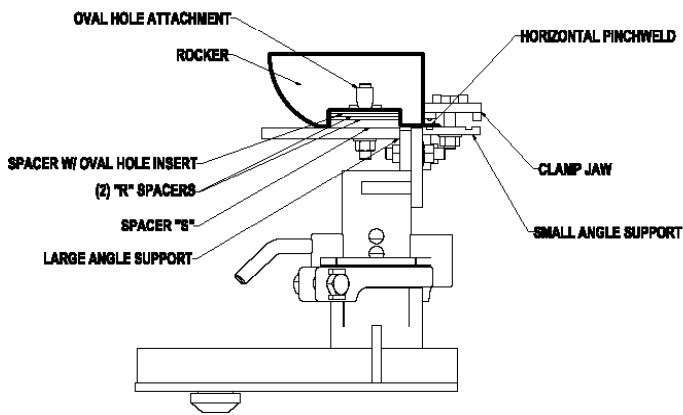

Figure 4

Front View Of Front Right Stand



Inset 1

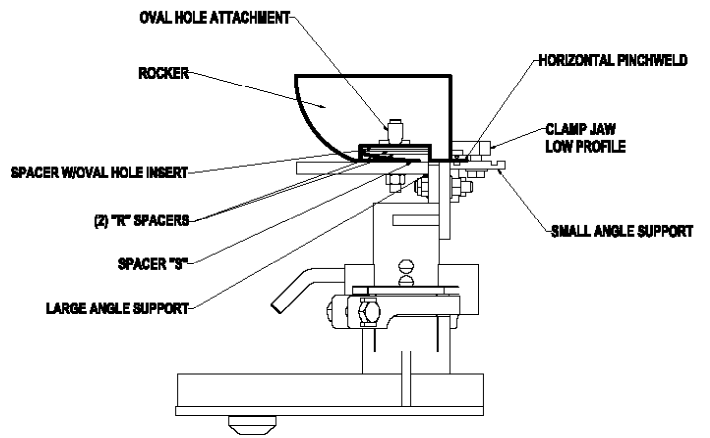

Rear View Of Rear Left Stand



Inset 2

BMW Z3 Roadster And Coupe Clamping Instructions

(Refer to illustrations on page 8.)

1. Remove vehicle's rocker panel cover and oval hole plugs located under rocker panel. Also remove fuel tank, hoses, lines, wires, brackets and undercoating if they will interfere with installation of anchoring equipment.
2. Remove clamp jaws from each anchoring stand.
3. Attach a large angle support to rear of each front anchoring stand and to front of each rear anchoring stand. (See Figure 4.)
NOTE: Attach supports to outside surface of anchoring stand's vertical plates as shown.
4. Attach a small angle support to the front of each front anchoring stand and at the center of each rear anchoring stand. (See Figure 4 - Insets 1 and 2.)
NOTE: Attach supports to inside surface of anchoring stand's vertical plates as shown.
5. Position oval hole attachment, spacer with oval hole insert, one 'S' spacer and two 'R' spacers, on top of large angle supports mounted to front and rear stands. (See Figure 4.) Threaded portion of attachment must project downward through spacers and through rear slot on front anchoring stands and through middle slot on rear anchoring stands. (See also Figure 4.)
6. Use appropriate lifting device to elevate one side of vehicle and position front anchoring stand so that front edge of vertical plate aligns with front edge of rocker panel at wheel opening. Top edge of vertical plate must also be directly under rocker reinforcement and horizontal pinchweld. Also align oval hole attachment with oval hole in bottom of rocker panel.
CAUTION:  Grip threaded portion of oval hole attachment when aligning attachment with oval hole in rocker panel. DO NOT place hands between rocker panel and anchoring components.
7. Lower vehicle so that oval hole attachment engages oval hole in bottom of rocker panel. Then grip threaded end of oval hole attachment to push attachment upward. Rotate attachment 90 degrees so that it straddles inside of oval hole in rocker plane and use 1/2 inch nut and washer to secure anchoring stand to rocker panel.
NOTE: To verify a secure hold, slightly raise the vehicle. If anchoring stand also raises, it is secure. If it doesn't, lower vehicle and repeat Step 7.
8. Secure clamp jaw to top surface of small angle support (see Figure 4 - Inset 1) engaging it with horizontal pinchweld in the process.
9. Repeat Steps 6 - 8 on opposite side of vehicle.
10. To install rear anchoring stand, raise side of vehicle and align rear edge of anchoring stand's vertical plate with rear edge of rocker panel at wheel opening. Top edge of vertical plate must be directly below rocker reinforcement and horizontal pinchweld. Also align oval hole attachment with oval hole in bottom of rocker panel.
CAUTION:  Grip threaded end of oval hole attachment when aligning attachment with oval hole in bottom of rocker panel. DO NOT place hands between rocker panel and anchoring components.
11. Lower vehicle so that oval hole attachment engages oval hole in bottom of rocker panel. Then grip threaded end of oval hole attachment to push attachment upward. Rotate attachment 90 degrees so that it straddles inside of oval hole in rocker panel and use 1/2 inch nut and washer to secure the anchoring stand to the rocker panel.
NOTE: To verify a secure hold, slightly raise the vehicle. If anchoring stand also raises, it is secure. If it doesn't, lower vehicle and repeat Step 11.
12. Secure clamp jaw - low profile (or half clamp) to top surface of small angle support (see Figure 4 - Inset 2) engaging it with horizontal pinchweld in the process.
13. Repeat Steps 6 - 12 on opposite side of vehicle.

BMW Z4 Series

NOTE: Clamping adapters mount to either the Universal Measuring System Pinchweld Stands (shown here) or to adapter tubes which fit in Universal Anchoring System Bases.

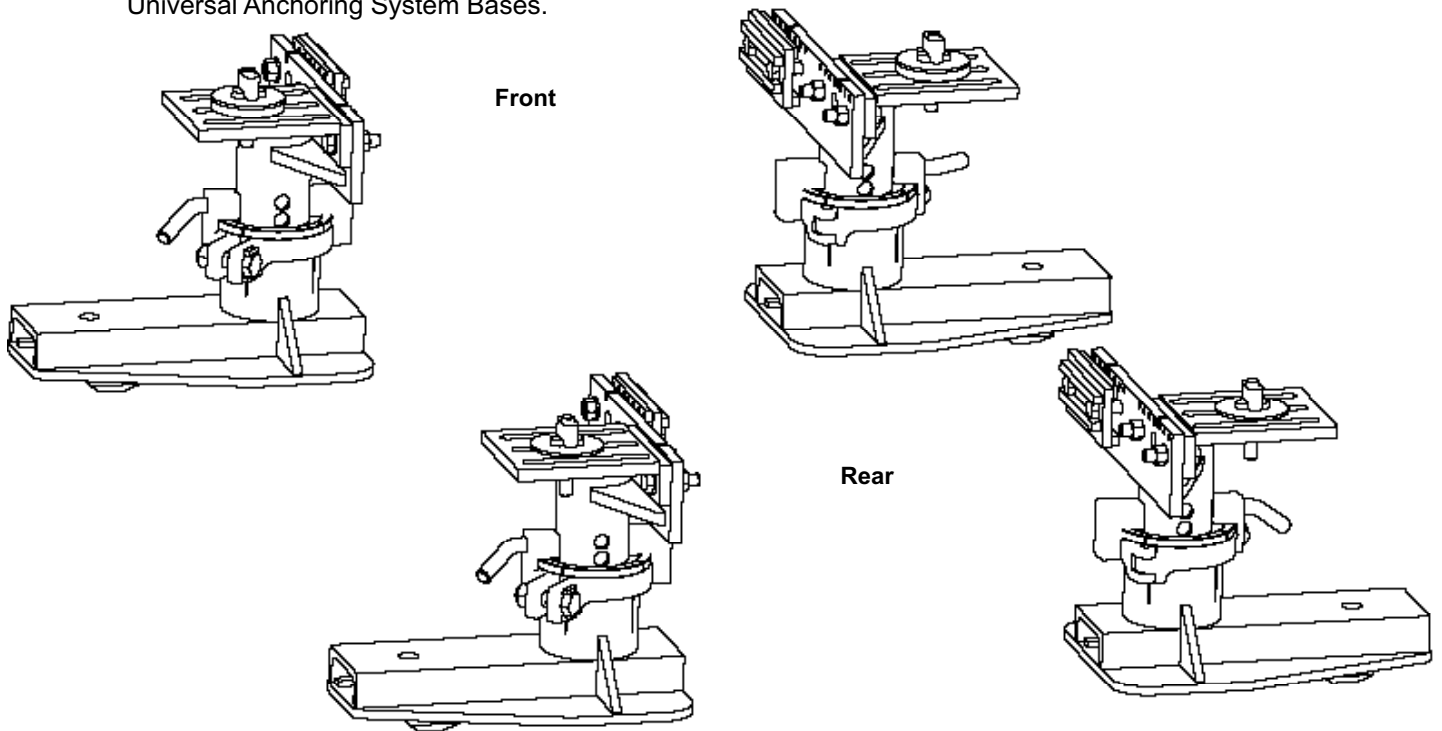
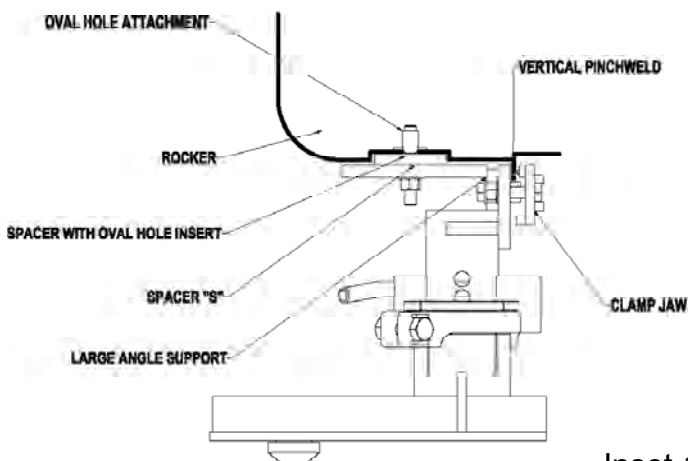

Figure 5

Front View Of Front Right Stand

Rear View Of Rear Left Stand



Inset 1

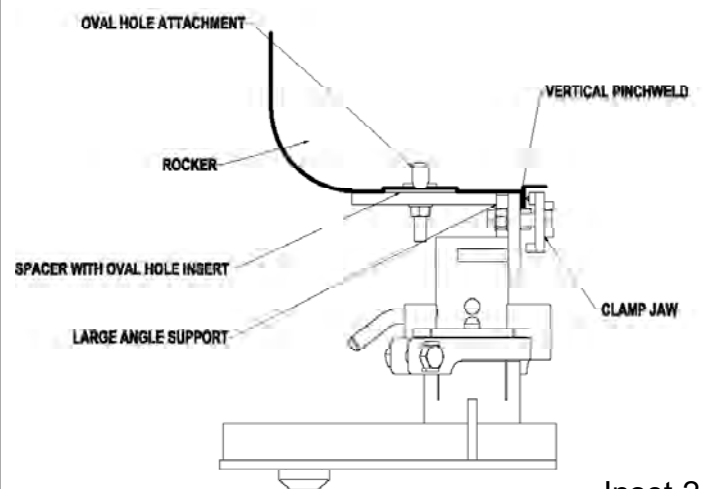

Inset 2

BMW Z4 Clamping Instructions

(Refer to illustrations on page 10.)

1. Remove vehicle's rocker panel cover and oval hole plugs located under rocker panel. Also remove fuel tank, hoses, lines, wires, brackets and undercoating if they will interfere with installation of anchoring equipment.
2. Remove clamp jaws from each anchoring stand.
3. Attach a large angle support to rear of each anchoring stand. (See Figure 5.)
NOTE: Attach supports to outside surface of anchoring stand's vertical plates as shown.
4. Attach a clamp jaw to the front of each anchoring stand.
5. Position oval hole attachment, spacer with oval hole insert and one 'S' spacer on top of large angle supports mounted to front stands. (See Figure 5.) Threaded portion of attachment must project downward through spacers and through middle slot on front anchoring stands. Position oval hole attachment, spacer with oval hole insert, on top of large angle supports mounted to rear stands (See Figure 5.) and through middle slot on rear anchoring stands. (See also Figure 5.)
6. Use appropriate lifting device to elevate one side of vehicle and position front anchoring stand so that front edge of vertical plate aligns with front edge of rocker panel at wheel opening. Top edge of vertical plate must also be directly under rocker reinforcement and horizontal pinchweld. Also align oval hole attachment with oval hole in bottom of rocker panel.
CAUTION: Grip threaded portion of oval hole attachment when aligning attachment with oval hole in  rocker panel. DO NOT place hands between rocker panel and anchoring components.
7. Lower vehicle so that oval hole attachment engages oval hole in bottom of rocker panel. Then grip threaded end of oval hole attachment to push attachment upward. Rotate attachment 90 degrees so that it straddles inside of oval hole in rocker panel and use 1/2 inch nut and washer to secure the anchoring stand to the rocker panel.
NOTE: To verify a secure hold, slightly raise vehicle. If anchoring stand also raises, it is secure. If it doesn't, lower vehicle and repeat Step 7.
8. Secure clamp jaw to pinchweld (see Figure 5 - Inset 1).
9. Repeat Steps 6 - 8 on opposite side of vehicle.
10. To install rear anchoring stand, raise side of vehicle and align rear edge of anchoring stand's vertical plate with rear edge of rocker panel at wheel opening. Top edge of vertical plate must be directly below rocker reinforcement and pinchweld. Also, align oval hole attachment with oval hole in bottom of rocker panel.
CAUTION: Grip threaded portion of oval hole attachment when aligning attachment with oval hole in bottom rocker panel. DO NOT place hands between rocker panel and anchoring components.
11. Lower vehicle so that oval hole attachment engages oval hole in bottom of rocker panel. Then grip threaded end of oval hole attachment to push attachment upward. Rotate attachment 90 degrees so that it straddles inside of oval hole in rocker panel and use 1/2 inch nut and washer to secure the anchoring stand to rocker panel.
NOTE: To verify a secure hold, slightly raise the vehicle. If anchoring stand also raises, it is secure. If it doesn't, lower vehicle and repeat Step 11.
12. Secure clamp jaw to pinchweld (see Figure 5 - Inset 2).
13. Repeat Steps 6 - 12 on opposite side of vehicle.

BMW 7 Series and 7 Series Long

NOTE: Clamping adapters mount to either the Universal Measuring System Pinchweld Stands (shown here) or to adapter tubes which fit in Universal Anchoring system Bases.

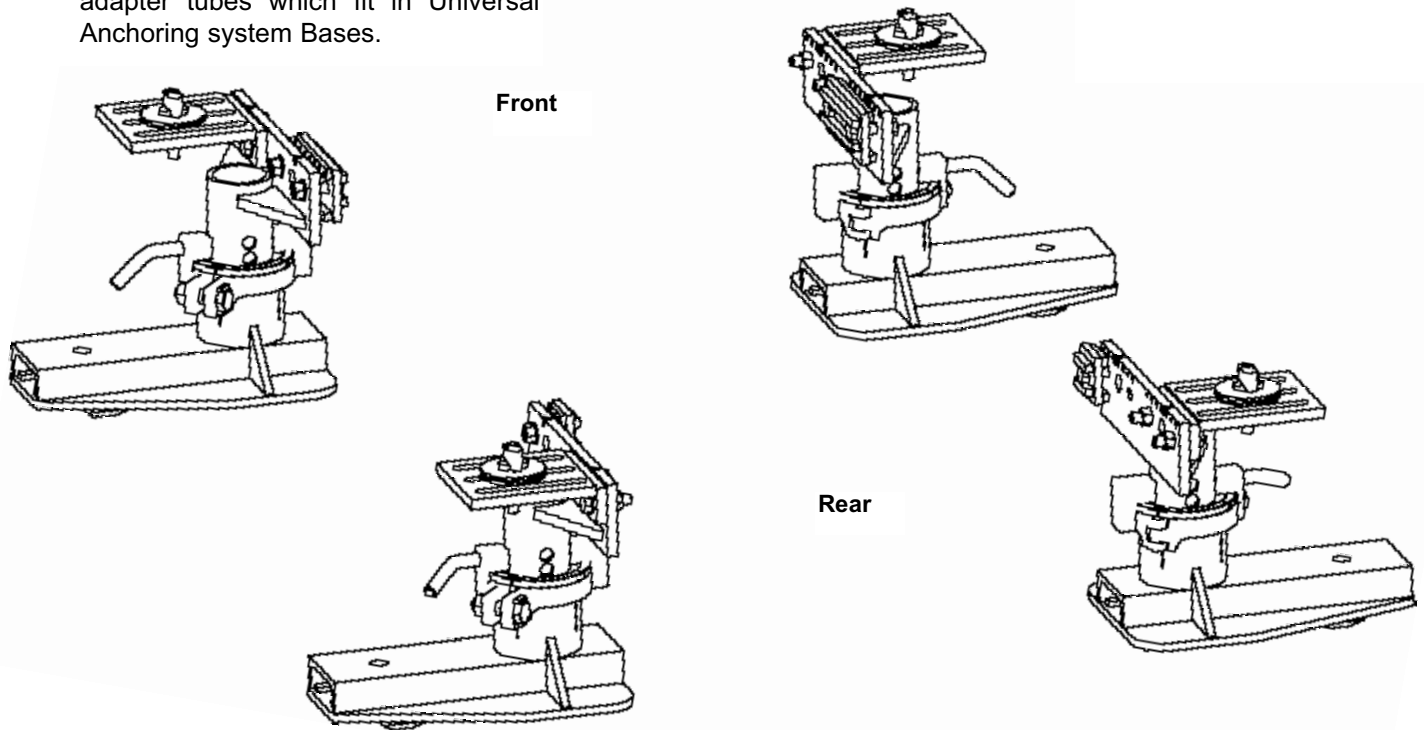
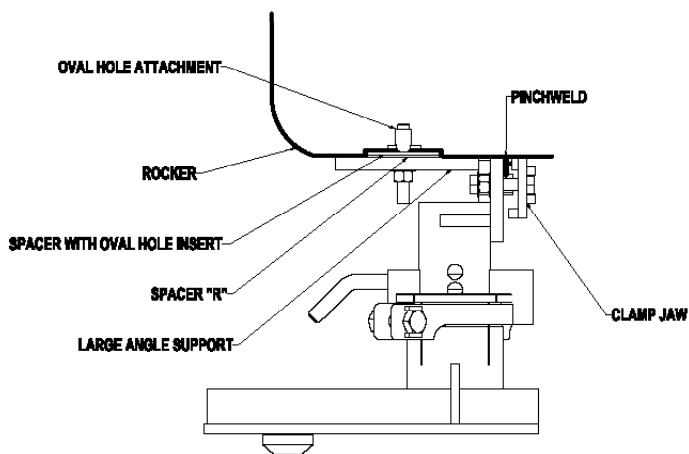

Figure 6

Front View Of Front Right Stand



Inset 1

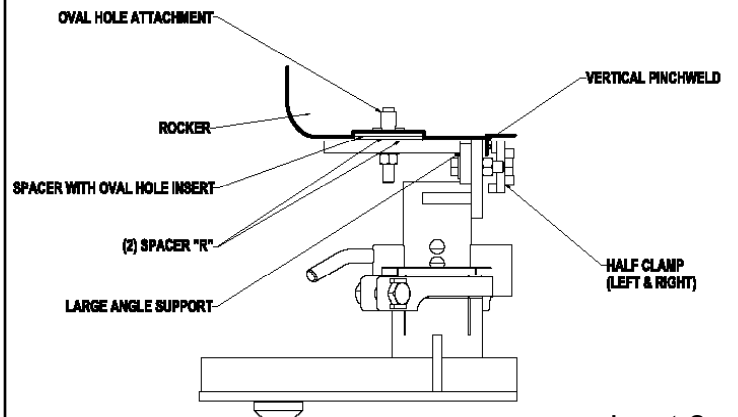

Rear View Of Rear Left Stand



Inset 2

BMW 7 Series and 7 Series Long Clamping Instructions

(Refer to illustrations on page 12.)

1. Remove vehicle's rocker panel cover and oval hole plugs located under rocker panel. Also remove fuel tank, hoses, lines, wires, brackets and undercoating if they will interfere with installation of anchoring equipment.
2. Remove clamp jaws from each anchoring stand.
3. Attach a large angle support to front of each front anchoring stand and to rear of each rear anchoring stand. (See Figure 6.)
NOTE: Attach supports to outside surface of anchoring stand's vertical plate as shown.
4. Attach a full clamp jaw to the rear of each front anchoring stand and a half clamp jaw to the front of each rear anchoring stand. (See Figure 6 - Insets 1 and 2.)
NOTE: Attach clamp jaws to inside surface of anchoring stand's vertical plates as shown.
5. Position oval hole attachment, spacer with oval hole insert and one 'R' spacer on top of large angle supports mounted to front stands. (See Figure 6.) Position oval hole attachment, spacer with oval hole insert, two 'R' spacers, on top of large angle supports mounted to rear stands. (See Figure 6.) Threaded portion of attachment must project downward through spacers and through rear slot on front anchoring stands and through middle slot on rear anchoring stands. (See also Figure 6.)
6. Use appropriate lifting device to elevate one side of vehicle. Top edge of vertical plate must be directly under rocker reinforcement and horizontal pinchweld. Align oval hole attachment with oval hole in bottom of rocker panel.
CAUTION: Grip threaded portion of oval hole attachment when aligning attachment with oval hole in rocker panel. DO NOT place hands between rocker panel and anchoring components.

7. Lower vehicle so that oval hole attachment engages oval hole in bottom of rocker panel. Then grip threaded end of oval hole attachment to push attachment upward. Rotate attachment 90 degrees so that it straddles inside of oval hole in rocker panel and use 1/2 inch nut and washer to secure the anchoring stand to the rocker panel.
NOTE: To verify a secure hold, slightly raise the vehicle. If anchoring stand also raises, it is secure. If it doesn't, lower vehicle and repeat Step 7.
8. Secure clamp jaw to surface of vertical pinchweld (see Figure 6 - Inset 1.)
9. Repeat Steps 6 - 8 on opposite side of vehicle.
10. To install rear anchoring stand, raise side of vehicle. Top edge of vertical plate must be directly under rocker reinforcement and horizontal pinchweld. Align oval hole attachment with oval hole in bottom of rocker panel.
CAUTION: Grip threaded portion of oval hole attachment when aligning attachment with oval hole in bottom of rocker panel. DO NOT place hands between rocker panel and anchoring components.

11. Lower vehicle so that oval hole attachment engages oval hole in bottom of rocker panel. Then grip threaded end of oval hole attachment to push attachment upward. Rotate attachment 90 degrees so that it straddles inside of oval hole in rocker panel and use 1/2 inch nut and washer to secure anchoring stand to the rocker panel.
NOTE: To verify a secure hold, slightly raise the vehicle. If anchoring stand also raises, it is secure. If it doesn't, lower vehicle and repeat Step 11.
12. Secure the half clamp jaw to vertical pinchweld.
13. Repeat Steps 6 - 12 on opposite side of vehicle.

Parts Ordering Information

To order replacement parts for BMW Clamping Adapters, call Chief Automotive Technologies, Inc. 800-445-9262. If located outside the United States, contact an authorized Chief Automotive Technologies, Inc. representative.

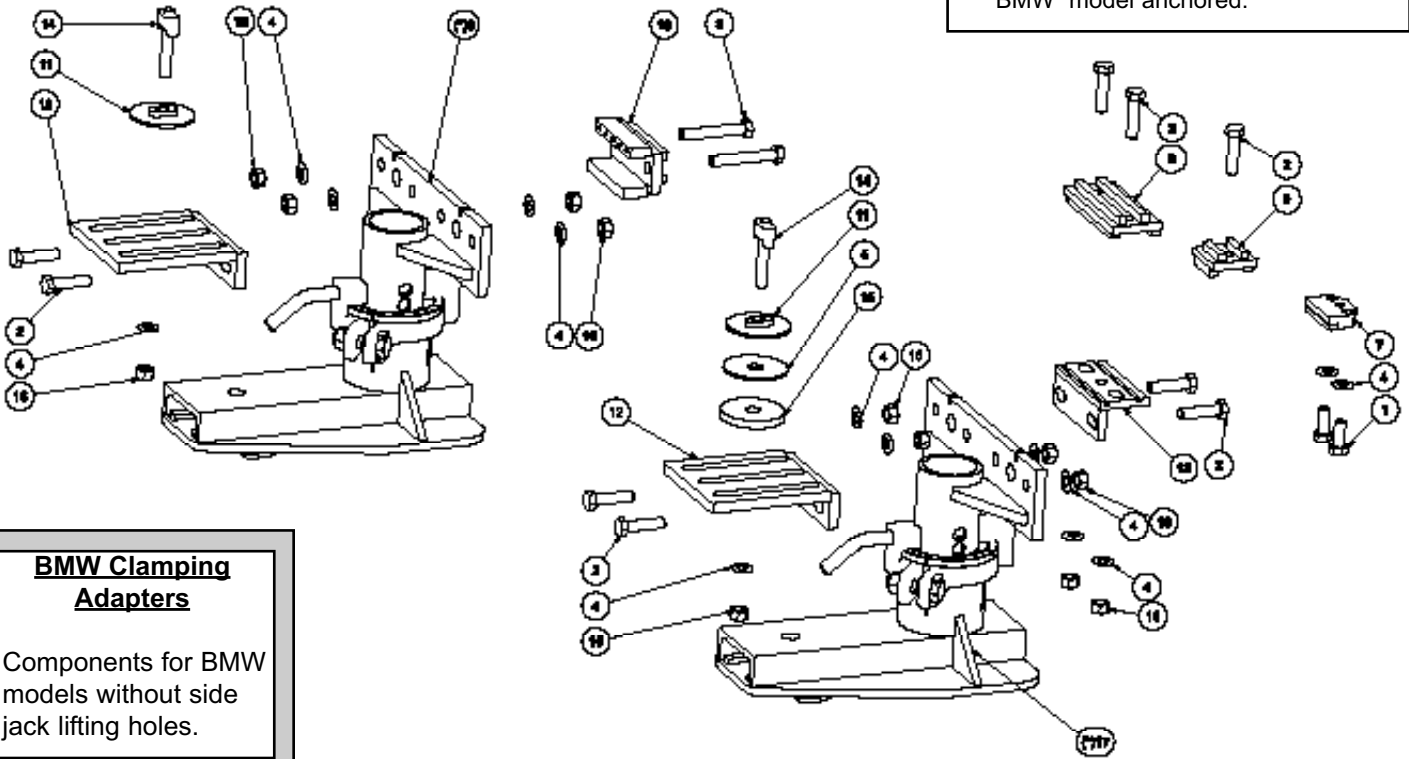
When contacting Chief Automotive Technologies, Inc. by telephone or mail, provide the following: name, name of shop, shop telephone number, shop address, description of part and part number. Refer to parts illustration and parts list below.

NOTE: BMW Clamping Adapters mount to either Universal Measuring System pinchweld stands or to adapter tubes which fit in Universal Anchoring System Bases (shown here). Arrangement of clamping adapters will vary dependent upon BMW model anchored.



BMW Clamping Adapters
Components for BMW models without side jack lifting holes.

Item	Part No.	Description
1	010625	Bolt, 1/2" x 1-1/4"
2	010628	Bolt, 1/2" x 2"
3	010633	Bolt, 1/2" x 3.25"
4	019095	Washer, .50 I.D., 16GA
5	092433	Round Spacer (R)
6	498102	Pinchweld Jaw
7	498106	Clamp Jaw, Low Profile
(*) 8	508281	Adapter Tube, UMS
9	518700 & 701	Half Clamp Assembly, Left & Right

Item	Part No.	Description
10	518830	Special Clamp Jaw (PP)
11	519611	Spacer, Round, W/Oval Inset
12	519632	Support, Main, Slotted
13	519633	Support Secondary, for Clamp Jaw
14	519637	Attachment, Oval Hole, 1/2"
15	532017	Round Spacer (S)
16	620736	Nut, 1/2"
(*) 17	702075	Assembly, Universal Anchoring Stand (Short)



P.O. Box 1368
Grand Island, Nebraska 68802-1368
Phone: 308/384-9747
Fax: 308/384-8966

www.chiefautomotive.com

**Chief reserves the right to alter product specifications and/or
package components without notice.**