

Anchoring Adapter System

USERS MANUAL





CHIEF'S LIMITED ONE-YEAR WARRANTY & LIABILITY

Chief Automotive Technologies, Inc. warrants for one year from date of installation and/or purchase any of its products which do not perform satisfactorily due to defect caused by faulty material or workmanship. Chief's obligation under this warranty is limited to the repair or replacement of products which are defective and which have not been misused, carelessly handled, or defaced by repair or repairs made or attempted by others.

CHIEF AUTOMOTIVE TECHNOLOGIES, INC. DOES NOT ASSUME RESPONSIBILITY FOR ANY DEATH, INJURY OR PROPERTY DAMAGE RESULTING FROM THE OPERATOR'S NEGLIGENCE OR MISUSE OF THIS PRODUCT OR ITS ATTACHMENTS. CHIEF MAKES NO WRITTEN, EXPRESS OR IMPLIED WARRANTY WHATSOEVER OF MERCHANTABILITY OR FITNESS FOR A PARTICULAR PURPOSE OR OTHERWISE REGARDING THE EQUIPMENT OR ANY PART OF THE PRODUCT OTHER THAN THE LIMITED ONE-YEAR WARRANTY STATED ABOVE.

Chief's Anchoring Adapter System can be used on a wide variety of pulling systems. Provided that operators have the correct size mounts, this system permits the installation of anchoring stands that allow use of the following anchoring / clamping systems: Universal Anchoring System, UMS (Universal Measuring System) Clamping System, and FAST Anchoring System.

IMPORTANT:

- 1) Usage of this system is dependent upon mainframe design and treadway width.
- 2) Prior to and during installation of this Anchoring Adapter System, refer also to the owners manual provided with the respective anchoring / clamping system being used.

- 1) Position clamp mount on top of machine's treadway at corners of vehicle's center section. Clamp mount should be installed as shown in Figure 1.
- 2) Clamp mount must engage inner edge of treadway and outer clamp must engage outer edge of treadway. (See Figures 2 and 3.) Slide outer clamp in as far as possible and secure bolts...finger tighten only!
- 3) Slide anchoring stand into clamp mount and position at desired location. (See Figure 4.)
- 4) Slide anchoring system tube into anchoring stand and secure at correct height using height adjusting pin. (See example of UMS Adapter Tube - Figure 5.)

NOTE: Any of Chief's anchoring tubes may be used in the anchoring stand.

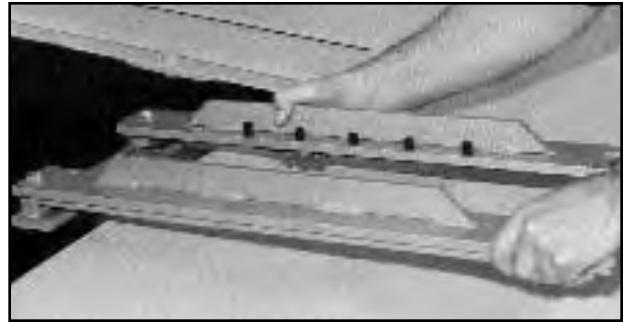

Figure 1



Figure 2



Figure 3

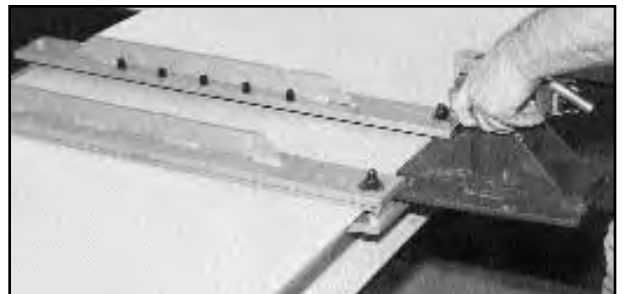

Figure 4



Figure 5

- 5) Attach clamping components to the anchoring tubes installed. Anchoring components may vary dependent upon anchoring system used. **DO NOT** attach to vehicle at this time!
- 6) Inspect clamping locations for fuel lines, brake lines, or other items which may interfere with placement of clamping attachments on vehicle. If attaching to vehicle's pinchweld, remove undercoating from pinchweld.
- 7) Attach clamping components to vehicle in accordance with instructions provided.

CAUTION: Heed all precautions relating to installation of anchoring / clamping components. Observe correct sequence of installation as it will vary dependent upon type of vehicle anchored and/or type of anchoring system used.

- 8) After attaching components to the vehicle, secure clamp mounts to treadway and anchoring stands within clamp mounts. The clamp mount bolts must be tightened to 80 foot pounds torque (maximum). The clamp mount hex socket set screws must be tightened - snug only. (See Figure 6.)



Figure 6

CAUTION: To avoid vehicle movement during repair, use turnbuckle and/or tie down chain when vehicle attachment point is 14 inches or more above mainframe.

Parts Information

To order parts for Chief's Anchoring Adapter System, contact the Chief Automotive Technologies, Inc. toll-free hotline answering service (800-445-9262) and leave a message. If located outside the United States, contact the nearest Chief Automotive Technologies, Inc. representative.

When contacting Chief by telephone or mail, provide the following information: name, name of shop, shop telephone number, and shop address. Additional information needed when ordering includes: description of part(s), part number(s), and method of payment and shipping charges.

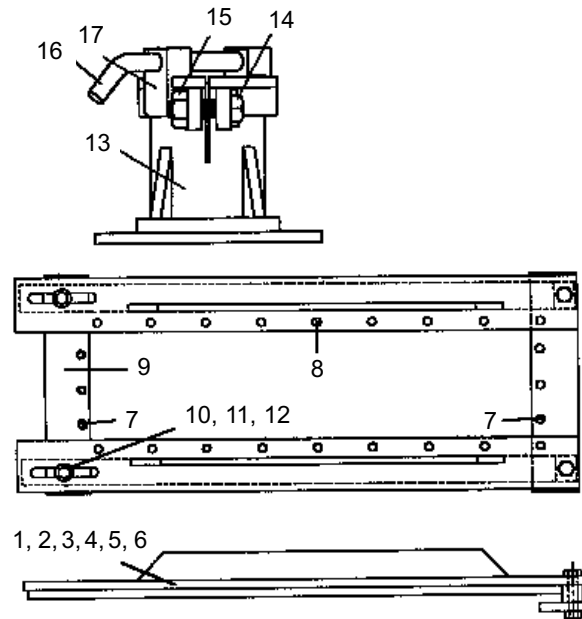

Ref.	Part No.	Qty.	Description
1	390010	1	Clamp Mount, 16" - 19"
2	390011	1	Clamp Mount, 19" - 22"
3	390012	1	Clamp Mount, 22" - 25"
4	390013	1	Clamp Mount, 25" - 28"
5	390014	1	Clamp Mount, 28" - 31"
6	390015	1	Clamp Mount, 31" - 34"
7	011639	1	Set Screw, 1/2 x 3/4
8	011640	1	Set Screw, 1/2 x 1
9	328104	1	Clamp Half, outer/with screws
10	539022	1	Bolt, M12 x 1.75 x 80mm
11	539024	1	Nut, M12 x 1.75, Hex
12	539025	1	Washer, Flat, M12
13	499105	1	Stand Base, Welded Ass'y
14	539006	1	Bolt, M20 x 2.5 x 60mm
15	539016	1	Nut, M20 x 2.5, Hex
16	606686	1	Height Adjusting Pin
17	607380	1	Locking Collar
	499110	1	Owners Manual



**P.O. Box 1368
Grand Island, Nebraska 68802-1368
Phone: 308/384-9747
Fax: 308/384-8966**

www.chiefautomotive.com

**Chief reserves the right to alter product specifications
and/or package components without notice.**