

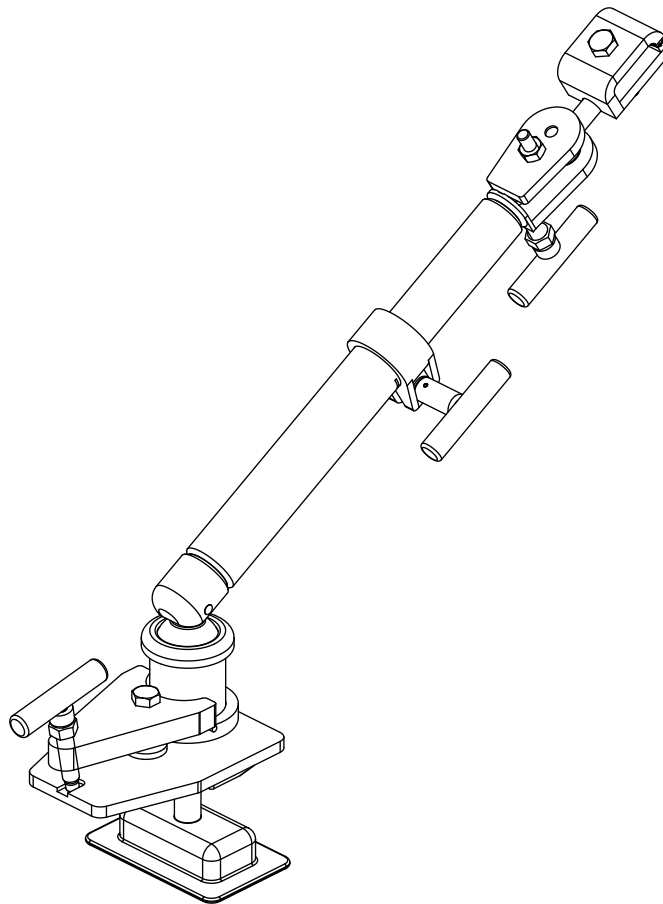

Parts Holding Attachment



CHIEF'S LIMITED ONE-YEAR WARRANTY & LIABILITY

Chief Automotive Technologies warrants for one year from the date of installation and/or purchase any of its products which do not perform satisfactorily due to defect caused by faulty material or workmanship. Chief's obligation under this warranty is limited to the repair or replacement of products which are defective and which have not been misused, carelessly handled, or defaced by repairs made or attempted by others.

CHIEF AUTOMOTIVE TECHNOLOGIES DOES NOT ASSUME RESPONSIBILITY FOR ANY DEATH, INJURY OR PROPERTY DAMAGE RESULTING FROM THE OPERATOR'S NEGLIGENCE OR MISUSE OF THIS PRODUCT OR ITS ATTACHMENTS. CHIEF MAKES NO WRITTEN, EXPRESS OR IMPLIED WARRANTY WHATSOEVER OF MERCHANTABILITY OR FITNESS FOR A PARTICULAR PURPOSE OR OTHERWISE REGARDING THE EQUIPMENT OR ANY PART OF THE PRODUCT OTHER THAN THE LIMITED ONE-YEAR WARRANTY STATED ABOVE.

I. INTRODUCTION

Many repairs require the replacement of subrails, aprons, strut towers, crossmembers and/or radiator supports. Such parts can be very difficult to align before welding to the vehicle.

The Chief Parts Holding Attachment takes much of the guesswork out of this task. It functions like an additional hand and secures parts at their precise locations.

Initially, the attachment holds the replacement part in position while the technician verifies its alignment to the vehicle using Chief's computerized measuring system. If adjustments are needed, the attachment's multi-adjustable pivot points and telescoping tube allow it to move "up or down", "in or out", and "fore or aft" to support the replacement part at its correct location.

When the replacement part is precisely aligned, the Parts Holding Attachment holds it secure while the technician welds it to the vehicle.

The Parts Holding Attachment is easy to install and fastens to any accessible tie-down hole on Chief's main frame.

IMPORTANT: The Chief Parts Holding Attachment is not designed to hold during the pulling process.

II. INSTALLATION

1) Select a tie down hole that allows the Parts Holding Attachment to secure the replacement part with its telescoping tube kept as short as possible, yet still allow appropriate working and welding space.

2) Place the attachment's locator plate in the selected tie-down hole (see Figure 1) and attach it to the main frame with the bolt and fastener plate.

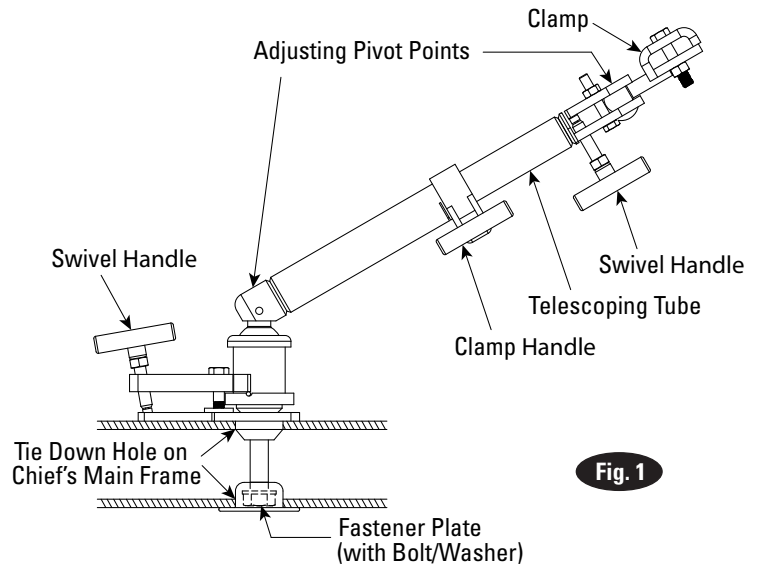

Fig. 1

3) Position the clamp so it is close to the correct location by using its adjustable pivot points and telescoping tube.

4) Install the replacement part into the clamp and select the correct location for it on the vehicle. Tighten all adjusting points to prevent unwanted movement. Use a measuring system and specification manual to align the new part. Weld the part into place per manufacturers recommended procedure.

III. USAGE EXAMPLE

Figure 2 shows a Parts Holding Attachment supporting a replacement subrail at the front of a vehicle. The attachment is very useful in such situations which require the careful positioning of replacement parts.

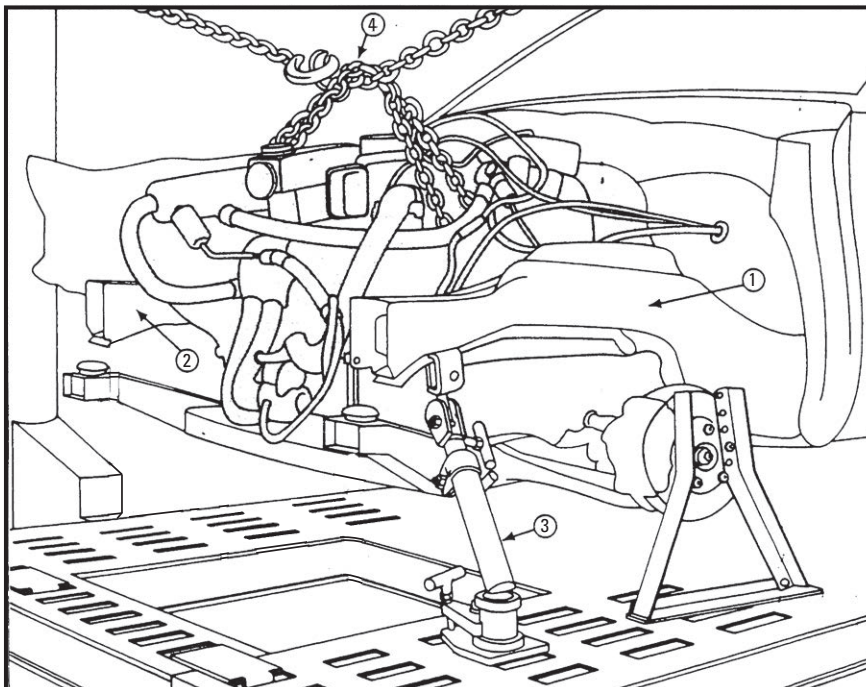

- ① Replacement Subrail (Driver Side)
- ② Original Subrail (Passenger Side)
- ③ Parts Holding Attachment
- ④ Tower Chains Support Engine/Drive Train Components

Fig. 2

When supporting subrails, the attachment should be at the outer end of the subrail to provide greater control and eliminate unwanted movement at this critical reference point.

Verify correct location of replaced part using 3-dimensional measuring system.

When alignment is achieved, the Parts Holding Attachment is secured and the replacement subrail is tack-welded to the vehicle.

The Parts Holding Attachment should remain in place through the next steps of the repair which in this case would include the assembly and tack-welding of the apron/strut tower, upper reinforcement and radiator support. The correct alignment of the components depends upon the correct positioning of the subrail ... in particular, the end that's supported by the Parts Holding Attachment.

After the structural components have been tack-welded, the alignment of the assembly should be verified. If correctly aligned, the structural components should be permanently welded using the vehicle manufacturer's recommended procedure. The Parts Holding Attachment should continue supporting the subrail during this phase of the repair as well.

IMPORTANT: Distribute welds so that an excessive amount of heat is not built up in any one area causing heat distortion.

Figure 2 also shows the engine and drive train components supported by tower chains because the engine cradle was unbolted to allow for structural part replacements. Once the new structural components are welded in place, the engine cradle will be reinstalled.

IV. TO REMOVE

To remove the Chief Parts Holding Attachment, loosen the clamping jaw and pivot points and move them to a position that allows for removal of the attachment. Remove the fastener plate, and bolt, then lift the attachment off the machine.

NOTES

NOTES

NOTES



Chief Automotive Technologies
996 Industrial Drive
Madison, IN 47250
Phone: 800-445-9262
Fax: 866-275-0173



www.chiefautomotive.com

Chief reserves the right to alter product specifications and/or package components without notice.